

lubrication systems



# TWIN-PUMP 2

## DOUBLE-LINE SYSTEMS

Designed to work all day, every day  
in extreme conditions and harsh environments



# TABLE OF CONTENTS

Applications	3	Motor	10
Description	4	Level gauges	11
Operation	5	Reversing valves	12
Advantages	6	Reversing valves	13
TWIN pump	7	Reversing valves	14
Twin-pump overall dimensions	8	Reversing valves	15
TWIN-PUMP configurator	9	Line inverter overall dimensions	16

## Applications

The electric TWIN-PUMP has been designed for all applications that use Double Line Systems.

The Double Line lubrication systems, generally used on medium and large sized machinery and equipment, operate in harsh or extreme operating conditions for the various points to be lubricated.

The systems can be very complex and longer than 100 metres. Any type of system can be designed and set up in a reliable, efficient manner, with the possibility of expansion.



PLATFORMS



LARGE CRANES



STEEL MILLS



CEMENT FACTORIES



MINING SECTOR

**Description**

The **TWIN 2** pumps, available with a 30 or 100 kg tank, have been designed with the aim of ensuring high reliability. They are able to develop a maximum pressure of 400 bar and a flow rate of 400 cc/1'. They are therefore able to feed large plants such as oil rigs, mining plants, cement plants, steel mills.

The pumps are equipped with electric level gauges, lubricant loading filters, reversing valves, pressure gauges and metal pallets for ground anchorage.

The pumps are designed on a modular basis and can be easily configured with very little effort. Please refer to the configuration tables at the end of this catalogue.

They have a very sturdy structure and operate effectively at temperatures between -25 a +80 ° C.



## Twin-pump and Mini Twin-pump operation



The core of the TWIN-PUMP 2 electric pump consists of the TWIN pumping unit housing the two elements that, being driven alternately by the central cams, draw and supply lubricant.

The alternate movement of the two pistons guarantees a constant and homogeneous flow of lubricant, high performance pressure to be reached (400 Bar) and the possibility of operating even if one of the two pumping elements were to stop.

The absence of return springs eliminates return issues or breakage.

The pressure gauge and the adjustable safety valve are also housed in the same body.

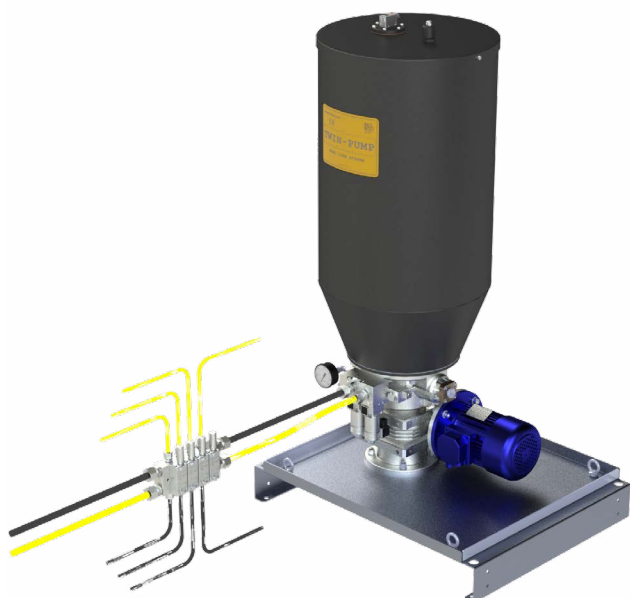

**STEP 1**

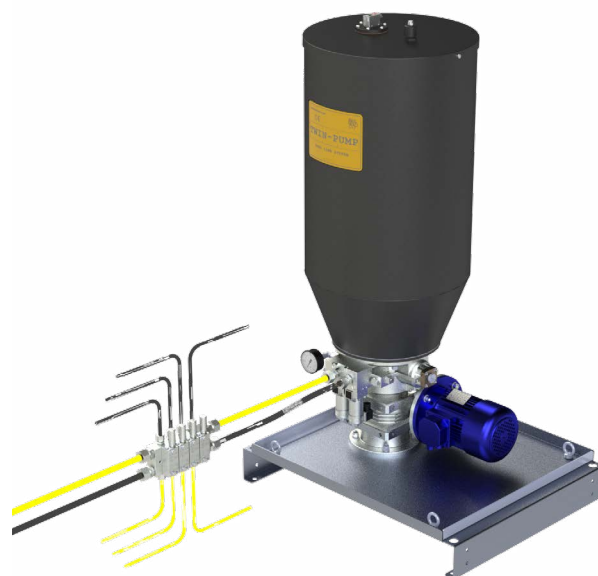

**STEP 2**

## Features and benefits

### Twin pumping unit

The pumping units can be quickly replaced since they are positioned on the right and left sides of the pump. Downtime during maintenance is reduced to zero and the risk of contamination is eliminated.

### Easy to use

The pump body is set up to receive the two pumping elements, the pressure relief valve, the pressure gauge and the electromagnetic or electro pneumatic converter.

### Efficiency

The system is always efficient with the double pumping unit. Constant lubrication can continue even if one module were to stop.

### External components

All pipes and the external components have been eliminated.

### High performance

High pressure values and flow performance can be reached so as to supply any type of circuit.

### Tanks

30 kg and 100 kg tanks for grease and oil with minimum and maximum level sensors; on request, AISI 316L execution.

### Solidity

A huge advantage in using the pump is the absence of return springs in the suction and delivery movement of metering pistons. All the problems caused by the springs malfunctioning are eliminated.

### Versatility

Available with motors having different voltages and in compliance with **UL-CSA / NEMA / ATEX standards**

### Customisable

The versatility and simplicity of the structure allows various customisations to be made to the assembly with additional components to provide a completely customised service.

### Reliable handling

To guarantee safe and reliable handling, the pumps are supplied assembled on a metallic pallet that can be picked up easily.

## Twin-pump

## Technical data

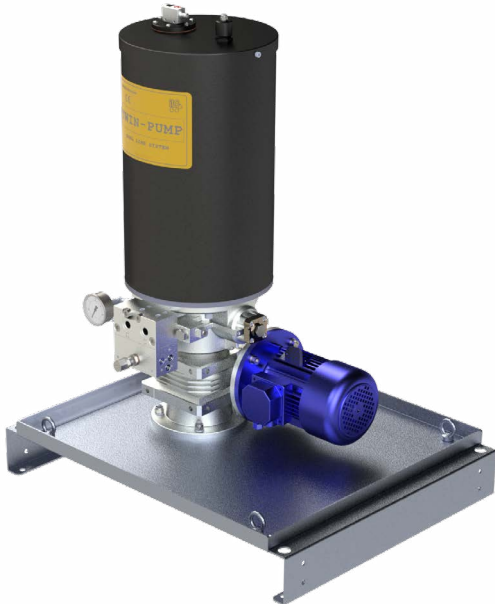

Operating principle	electric piston pump
Operating pressure	max 400 bar
Lubricant flow rate	400 cm <sup>3</sup> /minute 2 pumping units, 200 cm <sup>3</sup> /minute
Safety valve	adjustable from 50 to 400 bar calibrated as standard at 350 bar
Main line connection	3 / 8" BSP
Reversing valves	electrical, pneumatic or hydraulic
Protection rating	IP-65
Motor	0.75 Kw
Permitted lubricants	Min. oil 50 cSt Grease Max NLGI-2 (DIN 51818)
Tank capacity	30 kg or 100 kg
Oil tank filling	filling cap with 300 µm filter
Grease tank filling	1/2" BSP check valve with 300 µm filter
Pressure gauge	0 – 600 bar
Assembly position	vertical
Operating humidity	90% max
Operating temperatures	-25° C +80° C

## Height and weight

Tank	Weight	Total height
100 kg	100 kg (empty)	1316 mm
30 kg	85 kg (empty)	865 mm

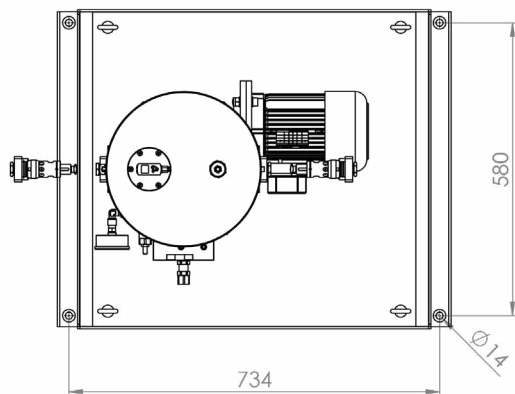
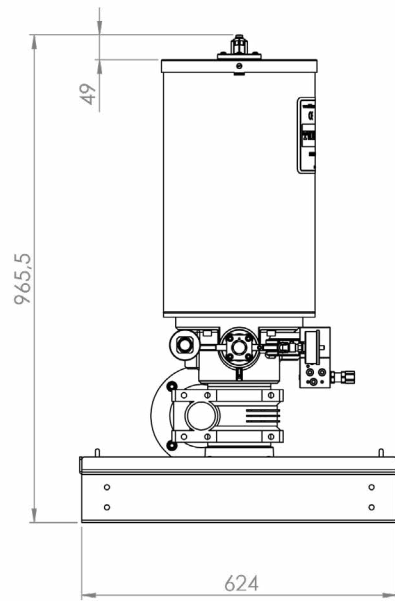
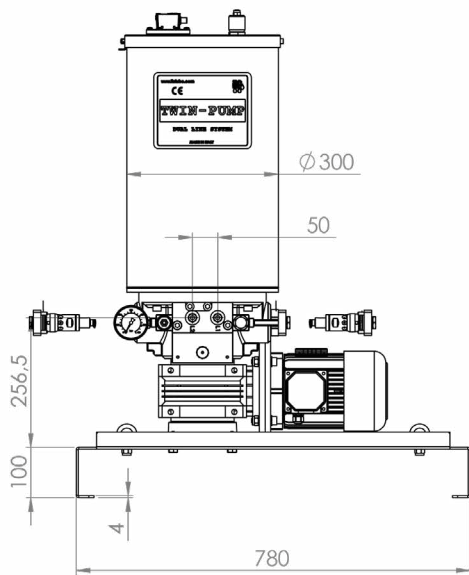
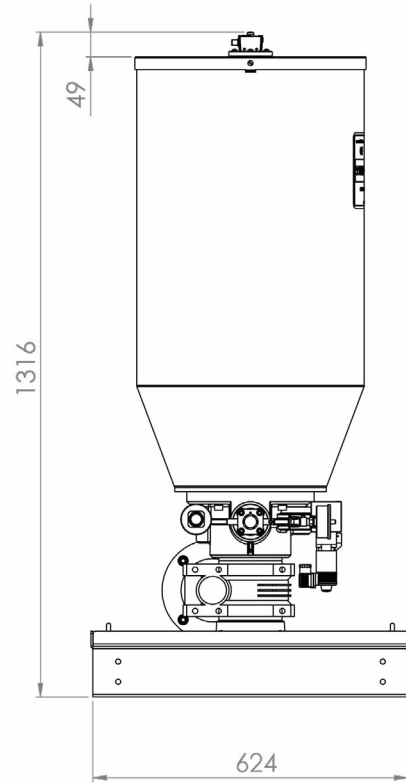
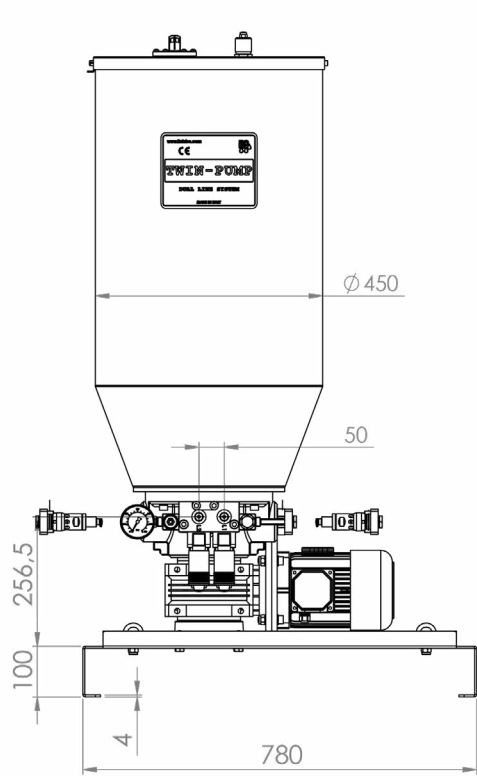



## TWIN-PUMP order code configurator

| 58 | . | G | . | 100 | . | S S | . | 5 | . | 1 | . | A | . | 1 | . | X |

A
B
C
D
E
F
G
H
I

### A (Lubricants)

Grease	G
Oil	O

### B (Reservoir)

#### Painted steel

100 kg	100
30 kg	030

#### SS316L

100 kg	10X
30 kg	03X

### C (Pump motor)

#### Three-phase Code

230/ 400V 50 HZ	S
280/ 480V 60HZ	S
460 V 60 Hz	H
380 V 60 Hz	F
575 V 60 Hz	D
500 V 50 Hz	E
550 V 50 Hz	G

#### Single-phase Code

115 V AC 60 Hz	B
230 V AC 50 Hz	C

Without motor	X
---------------	---

### D (Marking)

IE2 IP-65	S
UL-CSA	U
NEMA	N

### E (reversing valve)

#### Electromechanical

Voltage	Code
24 V DC	1
115 V AC	2
230 V AC	3

#### Pneumatic

Voltage	Code
24 V DC	4
24 V AC	5
115 V AC	6
230 V AC	7

#### Hydraulic

9

#### Without reversing valve

X

### F (Min-Max level gauges)

Laser sensor	1
No level	X

### F (Heating band)

Not present (standard)	A
Present	B

### H (Pallets)

Yes	1
No	X

### I (Box)

No Box	X
Steel Box IP-65	1
Box SS316L	2

## Motor

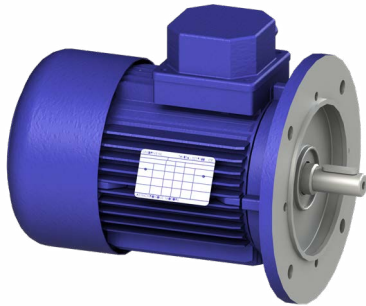

The TWIN-PUMP and Mini TWIN-PUMP series electric pumps have a standard configuration with a three-phase motor.

It is possible to supply single-phase motors 115 VAC, 230 VAC 50/60 Hz or motors with special voltages.

### Three-phase

Power supply voltage	Frequency	Absorption
230 V / 400 V	50 Hz	3.08 A / 1.78 A
275 V / 480 V	60 Hz	3.08 A / 1.78 A

### Single-phase

Power supply voltage	Frequency	Absorption
230 V AC	50 Hz	5.1 A
230 V AC	60 Hz	5.61 A
115 V AC	50 Hz	10.2 A
115 V AC	60 Hz	11.2 A

### Twin Pump motor

Power	0.75 kW
Protection rating	IP55
Service	S1 (continuous)
Insulation	Class F
Construction shape	B5
Size	Mec80
Weight	11.2 kg

Visual

Grease



The visual sensor is supplied as standard on all pumps to control the maximum grease level.

By rising, the float raises the visual rod which shows that the maximum level is reached in the tank.

Pump	Tank	Minimum	Maximum
TWIN	100-30 kg	-	A70.094154

Grease Laser Level

Grease



They measure the distance from the lubricant surface to the inside of the tank. They offer good accuracy and the measurement depends on the consistency of the grease. The lubrication low level signal is sent when there are still 10 kg of grease in the 100 kg tank and 3 kg in the 30 kg tank.

Pump	Tank	Maximum
TWIN	100 - 30 Kg	A70.094181

Oil float gauge

Oil

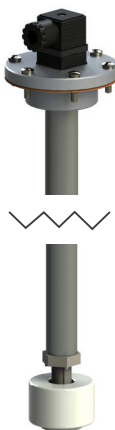

The reed sensor can be installed to check the minimum and maximum oil levels.

In the configurator, select the code for both the minimum and maximum level sensors.

Pump	Tank	Minimum	Maximum
TWIN	100 Kg	A70.094160	A70.094162
TWIN	30 Kg	A70.094161	A70.094162

## Electromagnetic inverter

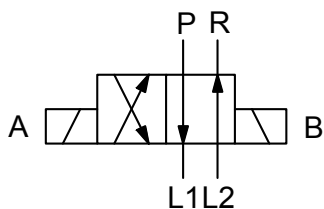
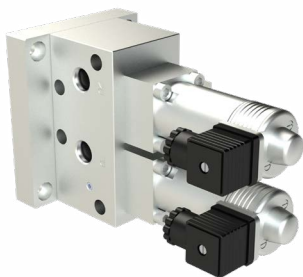

### for pump

Assembled	Block
58.IEM.115V	A51.082277
58.IEM.230V	
58.IEM.24DC	

### for line

Assembled	Inverter	Block	Plate
58.IEM.115V.L	58.IEM.115V	A70.093822	A51.082287
58.IEM.230V.L	58.IEM.230V		
58.IEM.24DC.L	58.IEM.24DC		

### Technical data

Maximum flow rate (oil 100 cst)	40 L/Min
Maximum pressure	400 Bar
Lubricants	Grease Max. NLGI 2
Voltage	24 V DC / 24 V AC - 50/60 Hz 115 V / 230 V AC - 50/60 Hz
Weight	12 kg
Operating temperature	-30° C - + 80° C
Humidity	90%
Protection ratings	IP-55
Inlets / outlets	G3/8" BSP

Pneumatic inverter

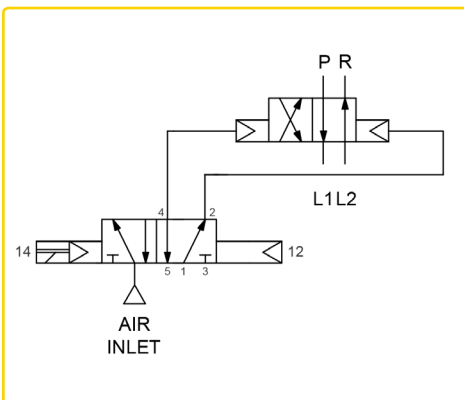
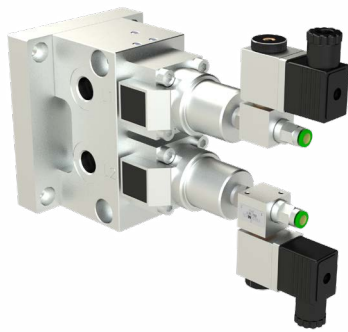

for pump

Assembled	Block
58.IEP.115V	A51.082277
58.IEP.230V	
58.IEP.24AC	
58.IEP.24DC	

for line

Assembled	Inverter	Block	Plate
58.IEP.115V.L	55.IEP.V.115V	A70.093822	A51.082287
58.IEP.230V.L	55.IEP.V.230V		
58.IEP.24AC.L	55.IEP.V.24AC		
58.IEP.24DC.L	55.IEP.V.24DC		

Technical data

Maximum flow rate (oil 100 cSt)	40 L/Min
Maximum pressure	400 Bar
Lubricants	Grease Max. NLGI 2
Voltage	24 V DC / 24 V AC - 50/60 Hz 115 V / 230 V AC - 50/60 Hz
Weight	11 kg
Operating temperature	-30° C - + 70° C
Humidity	90%
Protection rating	IP-55
Inlets / outlets	G3/8" BSP

## Hydraulic inverter

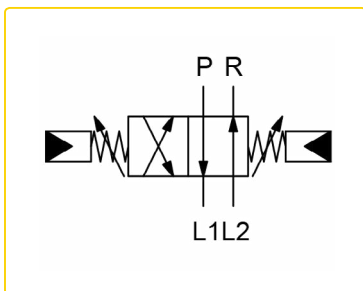

### For Pump

Assembled	Inverter	Block	Model
55.ISP10			Standard
55.ISP10.C	55.ISP10.V	A51.082216	Inductive Control

### For Line

Assembled	Inverter	Block	Model
55.ISP10.L			Standard
55.ISP10.L.C	55.ISP10.V	A51.082218	Inductive Control

### Technical data

Maximum flow rate (oil 100 cSt)	400 cc/Min
Exchange pressure adjustment	50-300 Bar – Setting 250 Bar
Max operating pressure	300 Bar
Lubricants	Grease Max. NLGI 2
Operating temperature	-25° C + 70° C
Humidity	90%
Protection ratings	IP-55
Seats L1-L2	G3/8" BSP

