

lubrication systems



ILCOMATIC 4

VOLUMETRIC METERING VALVES

FOR OIL AND SOFT GREASE OPERATION



General information	3
System structure	4
Design notes	6
Metering devices	7
Connections	8
Operation	9
Overall dimensions	11
Order code configurator	13
Fittings	14



All ILC products must only be used for their intended purposes, as specified in this brochure and in all instructions. If the product is supplied together with the user instructions, the user is required to read them and comply with them. Not all lubricants are suitable for centralised lubrication systems. ILC lubrication systems or relative components cannot be used together with gas, liquid gas, pressurised gas in solution and liquids with vapour pressure exceeding normal atmospheric pressure (1013 bar) by more than 0.5 bar, maximum temperature permitted. Any type of dangerous materials, namely those classified as such by European Community Directive (EC) 67/548/EEC, Article 2 (2), can only be used in ILC centralised lubrication systems or relative components upon consultation with ILC and after having received written approval from the company.

General information

ILCOMATIC-4 direct response metering valves are used in single-line centralised lubrication systems. They distribute and dose the lubricant at points through an intermittent pump. A precise amount of lubricant is dispensed with each lubrication cycle, from a minimum of 10 mm³ to a maximum of 160 mm³.

Main applications: machine tools, woodworking machines, textile machines, packaging machines, machines for plastics, machines for glass, printing machines and in general when a precise amount of lubricant is to be provided.

Models

Model	Lubricant	Type	Seals	Release pressure	Metering (mm ³)					
ILCOMATIC 4	Oil	Distributor	NBR	1 bar	10	20	30	60	100	160
ILCOMATIC 4	Soft grease	Distributor	NBR	3 bar	-	-	30	60	100	160
ILCOMATIC 4	Oil	Distributor	FPM	1 bar	10	20	30	60	100	160
ILCOMATIC 4	Soft grease	Distributor	FPM	3 bar	-	-	30	60	100	160

Lubricants

Oil-Grease that can be used	Metering mm ³	Operating pressure		Reset pressure	Operating temperature
Mineral - Synthetic Oil Density 20-2000 mm ² (compatible with NBR - Viton seals)	10 - 20	Min 14 Bar	Max 50 Bar	Max 3 Bar	0 - 80°C
	30 - 160			Max 1 Bar	
Soft grease NLGI grade 000 and 00 (compatible with NBR - Viton seals)	30 - 160	20 Bar	50 Bar	Max 3 Bar	

Reset time

Metering (mm ³)	Oils 20 - 220 cSt	Oils 250 - 2000 cSt	Soft greases NLGI 000-00
10 - 20	15"	30"	---
30 - 160	15"	30"	90"

The indicated values refer to system simulation with 20 metering devices and line pipes measuring a total length of 15 m Φ 6x4 mm. More metering devices and/or longer piping can increase the reset times.

Technical data

Marking of the metering fittings

Pipe output ϕ	4 mm	10 mm ³	10
Body	Ifex t2022	20 mm ³	20
Metering fitting	Brass	30 mm ³	30
Model pi	Push-in	60 mm ³	60
Model 00	Din 6382	100 mm ³	100
		160 mm ³	160

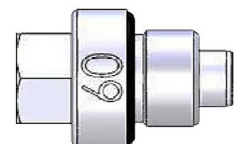

Single-line system structure

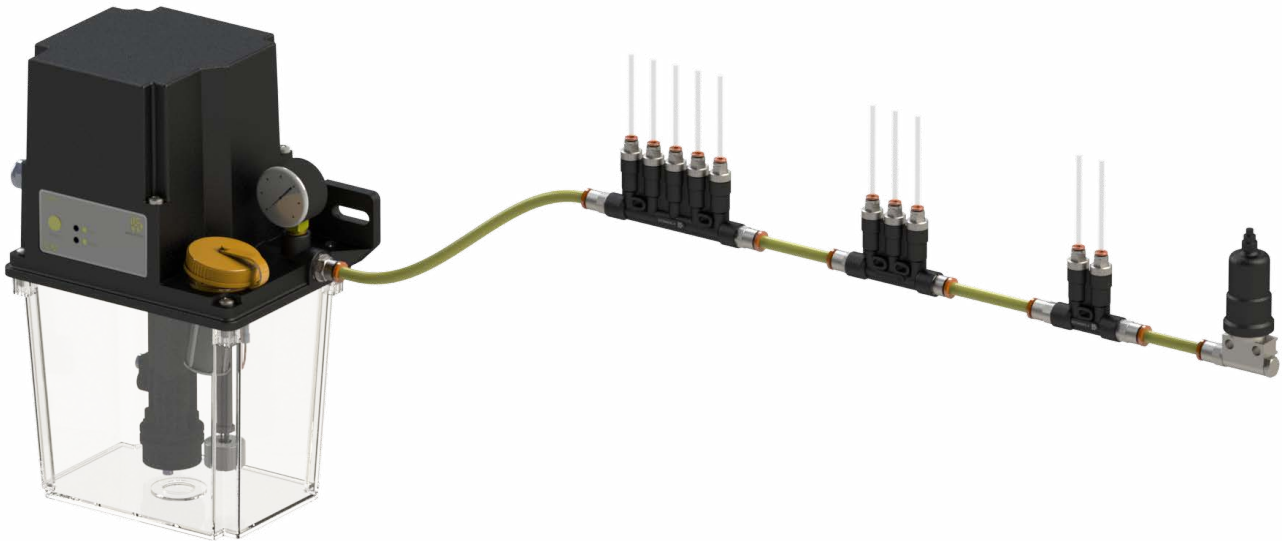

The system consists of a pump with a maximum pressure valve for system protection, a pressure switch to control the main line and a lubricant pressure relief valve. On demand, the pump can be supplied with a Timer.

If pressure drops greater than 10 bar are expected, for example due to the expansion of the pipes or the viscosity of the lubricant (depending on the ambient temperature), it is preferable to install a pressure switch at the end of the main line.

The pressure switch checks whether the pressure required for valve operation is reached during the lubrication cycle, and makes sure there are no leaks.

For the metering valves to work properly, the main line must be depressurised after the pump is stopped. This is guaranteed by the presence of the release valve.

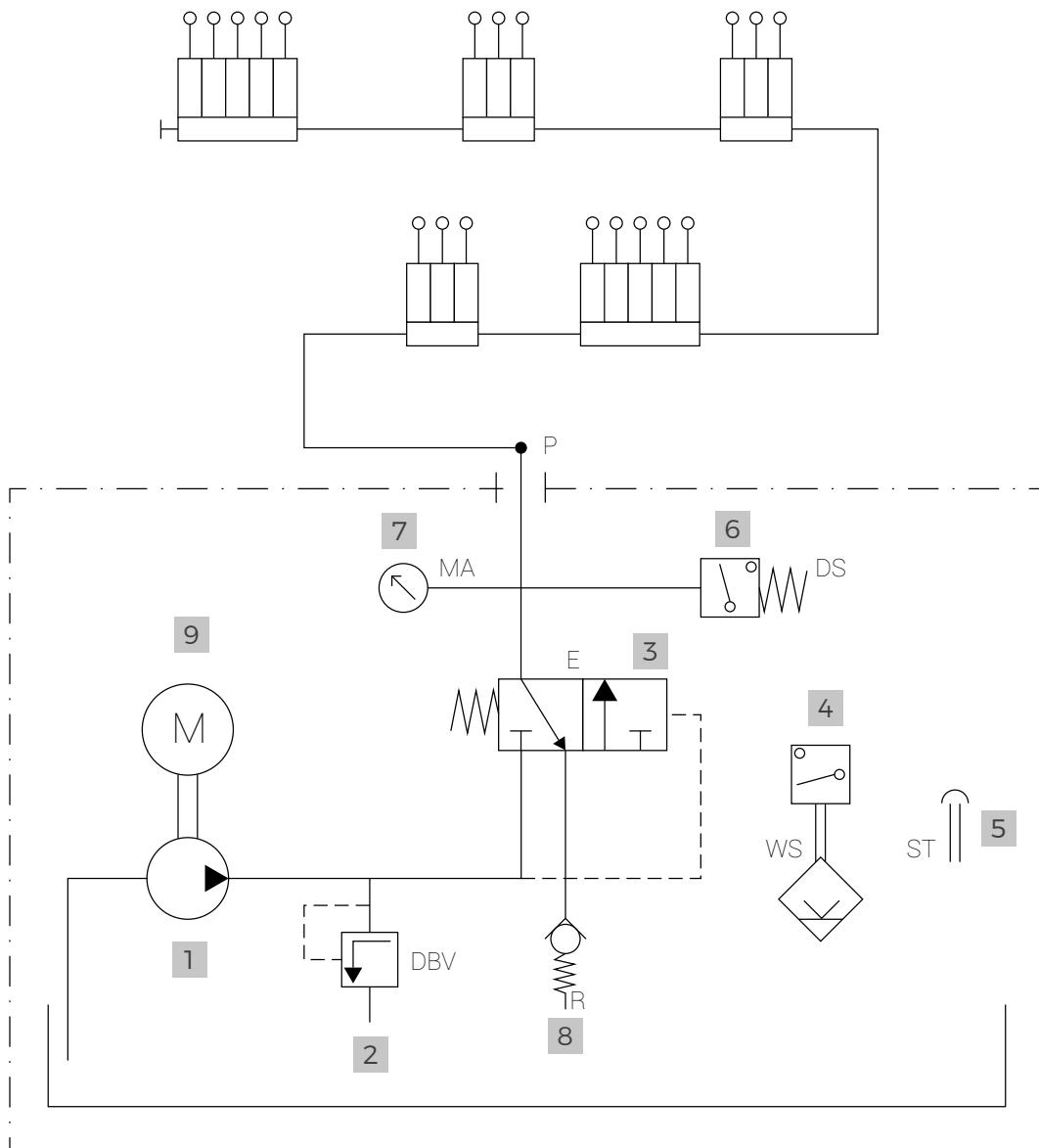

- | | |
|---|---|
| 1 gear pump (CME or MPT) | 6 oil pressure control pressure switch |
| 2 pressure relief valve | 7 pressure gauge |
| 3 release valve | 8 intake valve |
| 4 minimum level of lubricant check | 9 electric motor |
| 5 lubricant loading filter | |

Important design notes

It is advisable to comply with the following instructions for the design of the main line and the secondary lines for the points to be lubricated.

- A)** The main power line must be sized according to the pressure drops and the characteristics of the pump used. Starting from the lubrication unit, if possible, the main power line must have an upward progress, with the option of bleeding it at the highest point of the system.
- B)** Mount the distributor found at the end of the main power line with the outputs facing upwards. If the distributors must be placed below the supply line due to system requirements, this must not be carried out at the end of the line (Figure 1). If the lubrication lines must be brought to distributors found below the main power line, proceed as shown in Figure 2.
- C)** The lines, pipes, shut-off valves and distribution valves, fittings, etc. to be used must be chosen based on the maximum working pressure of the lubrication unit, the working temperatures and the lubricant to be dispensed.
- D)** The flow of the lubricant in the lubrication lines must not be obstructed by tight bends, valves and non-return valves.
- E)** Any variation in section that cannot be avoided in the lubrication lines must be carried out gradually. If possible, avoid sudden changes of direction.
- F)** Before assembly, thoroughly clean all system components, such as pipes, shut-off valves, distribution valves and fittings. The gaskets must not protrude inwards so as to prevent external agents from entering the system and not hinder the flow of lubricant. Basically, the lubrication lines must be positioned so as not to form air pockets at any point. Avoid small to large lubrication section variations in the lubricant flow direction. It is recommended to use drain plugs at appropriate points in the system.

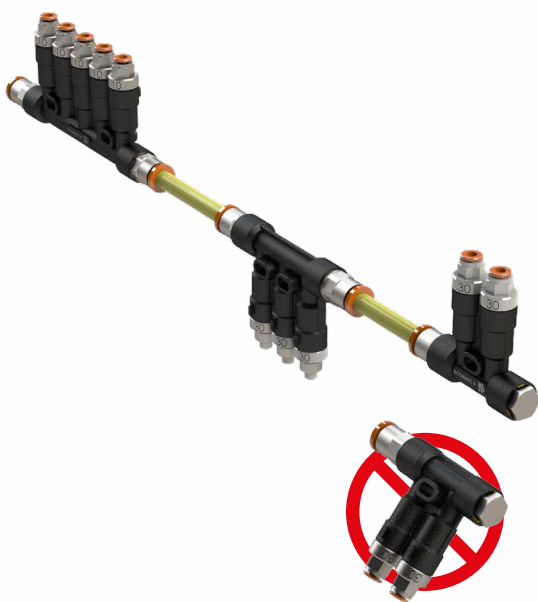
*fig. 1**fig. 2*

Ilcomatic 4



ILCOMATIC-4 single-line distributors are supplied with 2, 3 or 5 outputs. They can be ordered complete with fittings for the main line and towards the utilities. Follow the instructions in the “Ordering code configurator” chapter.

The dosages – between 10 mm³ and 160 mm³ – are marked on the metering nipple. To avoid confusion, we have made the models for oil in **black** and those for soft grease in **grey**.

The connection from the valve to the point to be lubricated is carried out using the quick couplings or by means of a fitting + double cone (DIN 3862). The lines to the point to be lubricated can be in metal, plastic or hoses with metal end shanks, generally with an external diameter of 4 mm.

An unused distributor output can be closed with a pressure cap used for the quick couplings series or a threaded cap used for the fitting + double cone series.

The metering nipples are interchangeable for flow rates of/or above 30 mm³.

The gaskets inside the valves are made of NBR or FPM, according to the version. The distributor body is in PARA IFEX 50FG and has fastening holes.

The housing of the main line on the body of the distributor has a M10x1 thread. There are various types of fittings + double cone, quick couplings and caps, depending on the different sizes of the main line piping. Further information is available on the following pages.



Connections



The figure below indicates all the fittings available for the distributors and the outputs. The order configuration table allows a single-line distributor with supply fittings to be combined in a single code.

The quick coupling system for plastic or metal pipes facilitates the installation of a line in a safe, rapid, leak-free and economical manner. The system includes a fitting for pipes with a diameter of 4, 6 and 8 mm in the standard straight and 90° orientable shapes, and output metering devices.

Inside there is a gripper fitted with a hook that acts on a groove in the metal pipe or directly on the plastic pipe used. This way, the pipes installed remain anchored in the quick coupling. The quick couplings are suitable for the entire lubrication system, from the lubrication unit to the distributor, to the pressure switch and to the points to be lubricated.

The fittings for the main line can be mounted on the right and/or on the left side of the distributor body. The order configuration table allows a single-line distributor with supply fittings to be combined in a single code.



Operation

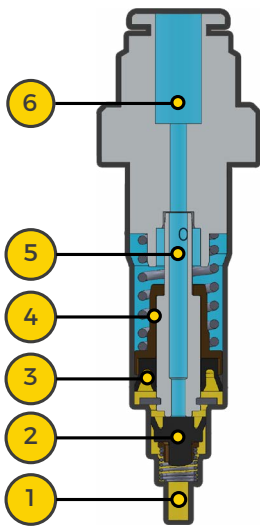

A) Valve in stand-by. **(1)** Main line **(2)** Cap gasket **(3)** Load zone **(4)** Metering piston **(5)** Metering chamber **(6)** Output line.

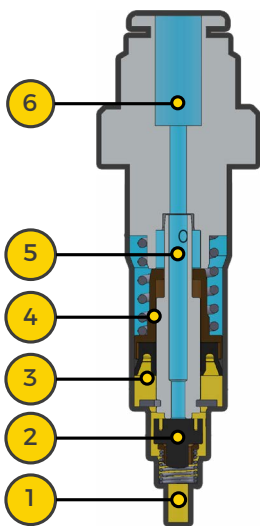

B) The pressurised oil reaches the hole **1** by pressing the pump, and by tightening the seal lip **2** the lubricant enters the zone **3**, moving the piston **4** accordingly. Upon the first actuation, the metering device will expel air to the output **6** through the metering chamber **5**.

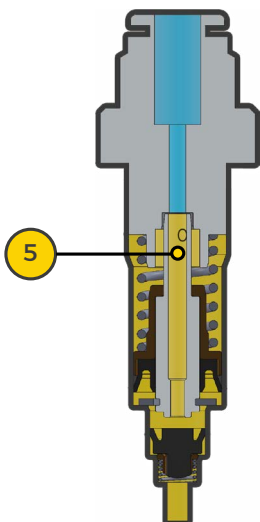

C) After several actuations, the metering chamber **5** will be filled with oil, as shown in the figure, with the pump stopped.

Operation (continuous)

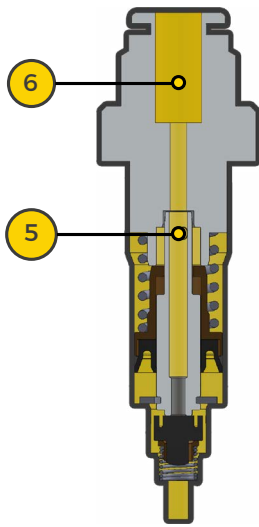

D) By actuating the pump again, the oil in the metering chamber **5** will be conveyed to the point to be lubricated.

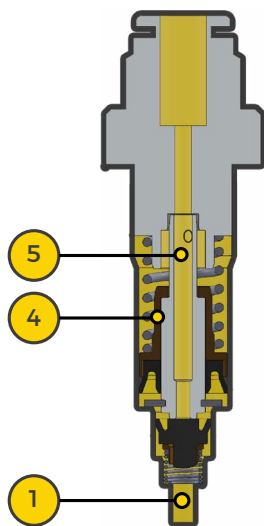

E) By eliminating the pressure, the gasket **1** and the piston **4** return to the initial position and allow the oil to fill the metering chamber **5** completely in order to be ready for a new cycle.

Push-In Output Model

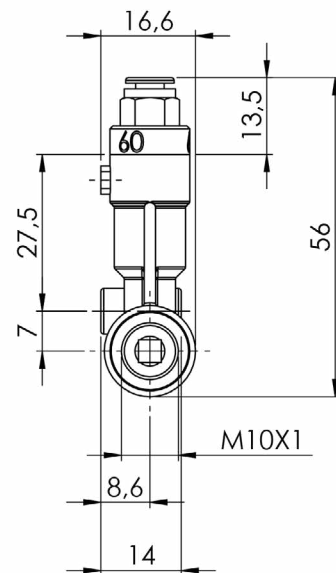
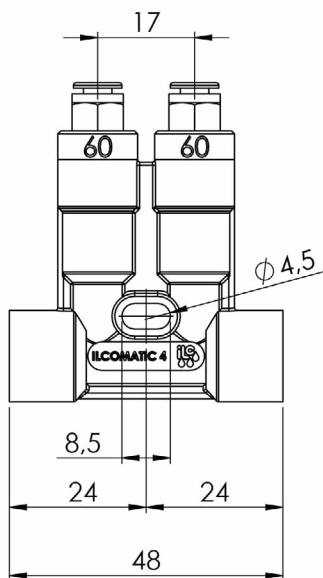
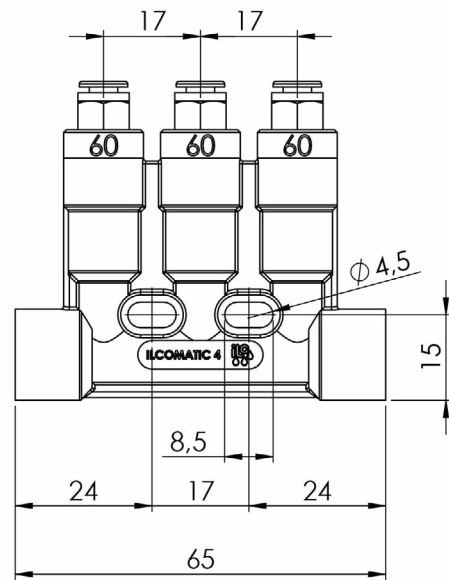
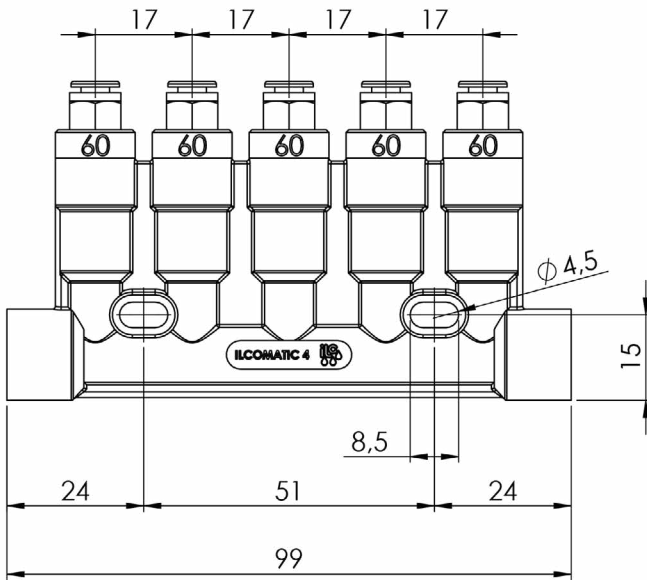

Ogive-Fitting Output Model

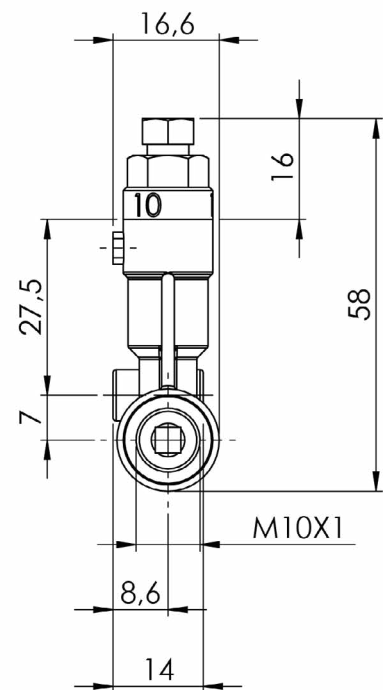
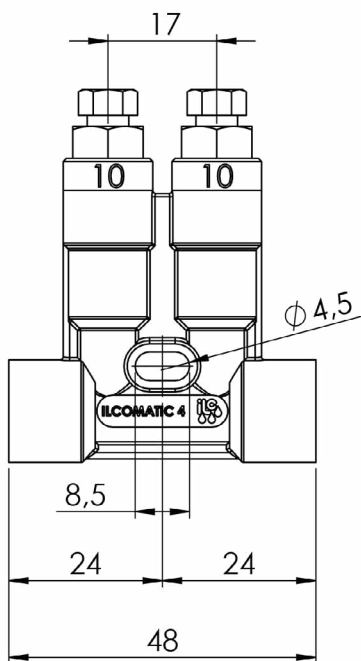
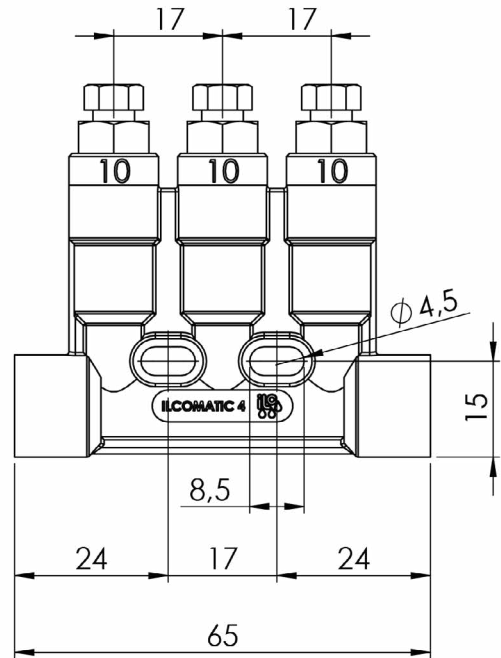
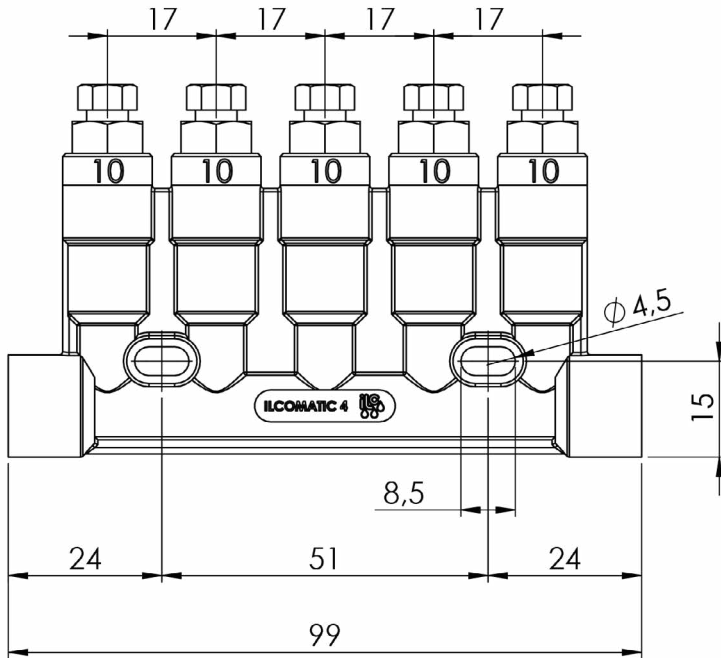

Order code configurator

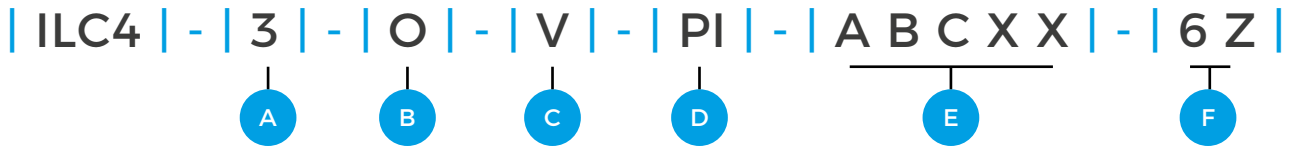







A (Number of outputs)		E (Metering)		F (LH/RH Fittings)		
2		<i>Non-selectable metering A - B with Soft Grease.</i>		Without	m10x1 F	X
3		10	A	DIN 3862		
5		20	B	Straight	6 [mm]	1
B (Lubricant)		30	C	Straight	8 [mm]	2
Oil	O	60	D	Banjo	6 [mm]	3
Soft grease 000 - 00	G	100	E	Banjo	8 [mm]	4
C (Seals)		160	F	Cap	-	Z
NBR	N	Closed	T	PUSH-IN		
FPM	V			Straight	6 [mm]	5
D (Outputs)				Straight	8 [mm]	6
Push-in	PI			90°	6 [mm]	7
Ogive	00			90°	8 [mm]	8
				Cap	-	Z

Coding example



- A** | 5-output distributors
- B** | For Oil
- C** | NBR Seals
- D** | PUSH-IN outputs
- E** |
 - output 1 = 10 mm³
 - output 2 = 10 mm³
 - output 3 = 60 mm³
 - output 4 = closed
 - output 5 = 160 mm³
- F** |
 - Push-in straight left Line fitting ø 6 mm
 - Push-in 90° right Line fitting ø 6 mm

Main line fittings M10x1	Code	Ø Pipe	Figure	CH	Ref. Configurator
	A92.106715	6	straight	12	5
	A92.106716	8	straight	13	6
	A92.106717	6	90°	12	7
	A92.106718	8	90°	12	8
	TW.100602	6	straight	14/12	1
	TW.100603	8	straight	14/14	2
	A92.106719	6	90°	14/12	3
	A92.106720	8	90°	14/14	4
	05.052.0	Cap M10x1		4	Z

Metering Fittings (Ø Pipe 4 mm)	Push-In (PI)	Ogive Fitting (00)	Metering
	02.616.010	02.617.010	10 mm ³
	02.616.020	02.617.020	20 mm ³
	02.616.030	02.617.030	30 mm ³
	02.616.060	02.617.060	60 mm ³
	02.616.100	02.617.100	100 mm ³
	02.616.160	02.617.160	160 mm ³

Cap for Push-In (Ø Pipe 4 mm)	Output cap M8x1	Fitting/Double cone (Pipe 4 mm)
A92.106497	05.001.2	A52.131016
		04.102.2
		06.002.0



Distributor Coupling Grease Nipple M10x1

It comes complete with an O-ring for alignment For tightness use medium sealant on the threads
09.600.7