



TWIN-PUMP

Dual line system

Designed to work all the day, every day
in extreme condition and difficult environments



CONTENTS

Applications	3
Description	4
Operation	5
Benefits	6
TWIN pump	7
TWIN measures	8
TWIN-PUMP configurator	9
Mini TWIN-PUMP	10
Mini Twin-pump size	11
Mini TWIN-PUMP configurator	12
Drive motor	13
Electrical level indicators	14
Electrical level indicators (follows)	15
Electro-mechanical reversing valve	16
Pneumatic reversing valve	17
Hydraulic reversing valve	18

Applications

The TWIN-PUMP pumps are designed primarily for dual-line systems in industrial applications.

Dual-line lubrication systems, generally used on machinery and plants of medium to large size, operate in difficult or extreme working conditions in order to lubricate the multiple points.

The systems can be quite complex and reach a length greater than 100 meters. Any type of system can be designed and realized in a easy-to-expand, reliable and efficient way,



Description

TWIN-PUMP, available with a 30 or 100 Kg reservoir, have a maximum operating pressure of 400 bar and a 400cc/1' flow rate. Depending on the system layout, these electric pump can supply lubricant up to 120 meters far.

Mini TWIN-PUMP, available with a 10 or 30 Kg reservoir, have a maximum operating pressure of 350 bar and a 25cc/1' flow rate. They can send lubricant up to 60 meter far.

Pumps are provided with relief valve, check valve, lubricant filter, inversion valve, pressure gauge and metal pallet for ground fixing.

Pumps are designed on a modular basis and they can be easily configured. Refer to configuration tables after each pump description.

They have a solid structure and they operate efficiently between -25 to +80° C degree.



Twin-pump e Mini Twin-pump operation



The core of TWIN-PUMP is the TWIN group. TWIN group houses two elements (one in the Mini version) which, actuated by the central cam with an alternate movement, aspire and deliver lubricant.

The pistons alternate movement grants a constant and uniform flow rate, as well as high pressure performances (400 bar) and the possibility to operate even if one of the elements stops.

Return springs have been removed in order to avoid any returning issue or damage.

In the same housing are placed both the pressure gauge and the adjustable check valve.

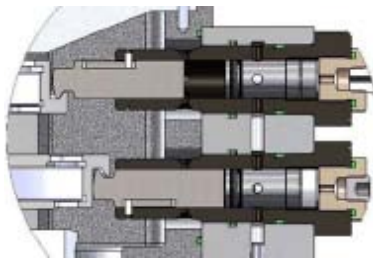

fase 1

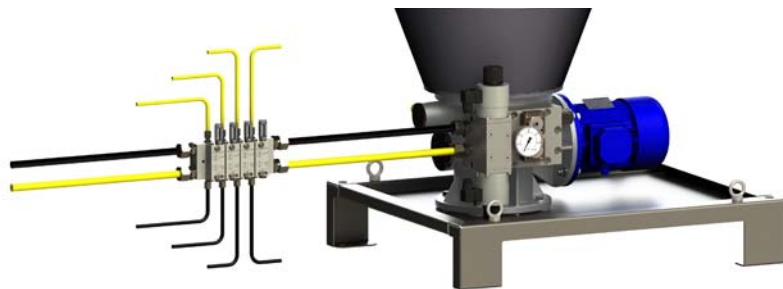

fase 2

Features and benefits

Twin pumping group

The pumping units are placed in the front side of the pump and can be quickly replaced. Downtime during maintenance is reduced to zero and the risk of contamination is eliminated.

Easily operated

The pump housing is designed to host the pumping element, the maximum pressure valve, the pressure gauge and the magnetic/pneumatic/hydraulic or electro-hydraulic reversing valve.

Efficiency

The TWIN group grants high level of efficiency. Lubrication is uniform and can work even when one of the module stops.

Internal components

All the external component and piping have been removed.

High performances

The TWIN unit allow to reach high levels of pressure and improves the flow performance on any kind of lubrication systems.

Reservoir

30 kg and 100 kg oil or grease reservoir with min/max electrical level indicators. AISI 316L tank by request.

Strength

The major advantage of the system is the absence of returning springs in order to control the piston movement. Issues related to spring breaking are completely eliminated.

Versatility

Available with different motor configuration and with UL-CSA / NEMA ATEX markings.

Customizable

The simple and versatile structure allows for many assembling customization with additional component.

Easy to move

Pumps are provided with a metal pallet for safe and reliable handling.

Twin-pump

Technical data



Functioning principle	electrically operated piston pump
Operating pressure	max 400 bar
Lubricant output	400 cm ³ minute 2 pumping elements 200 cm ³ /m
Safety valve	adjustable from 50 to 400 bar default set 350 bar
Main line connection	3 / 8" BSP
Reversing valve	electric, pneumatic o hydraulic
Protection class	IP-65
Drive motor	0,75 Kw
Suitable lubricant	Oil Min. 50 cSt Grease Max NLGI-2 (DIN 51818)
Reservoir capacity	30 kg o 100 kg
Reservoir loading (oil)	filling cap with 300 µm filter
Reservoir loading (grease)	1/2" BSP check valve with 300 µm filter
Pressure gauge	0 – 600 bar
Mounting position	vertical
Humidity	90% max
Operating temperature	-25° C +80° C

Height and weight

Reservoir	Weight	Total height
100 kg	100 kg (empty)	1282 mm
30 kg	85 kg (empty)	932 mm

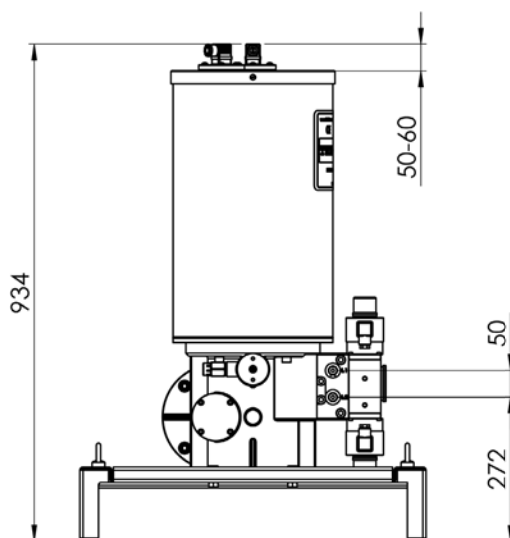
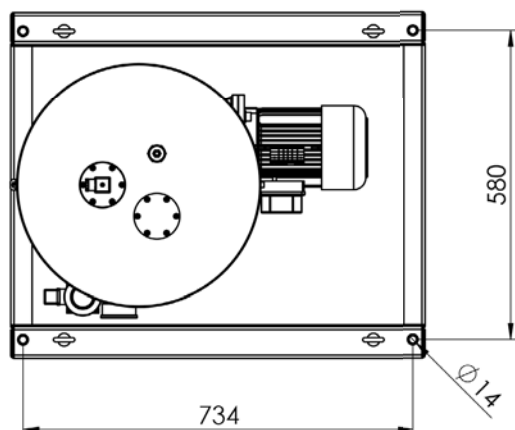
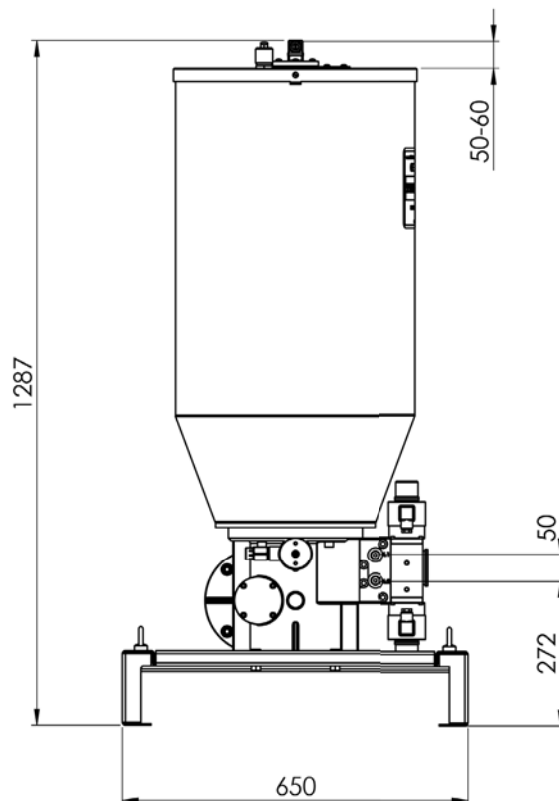
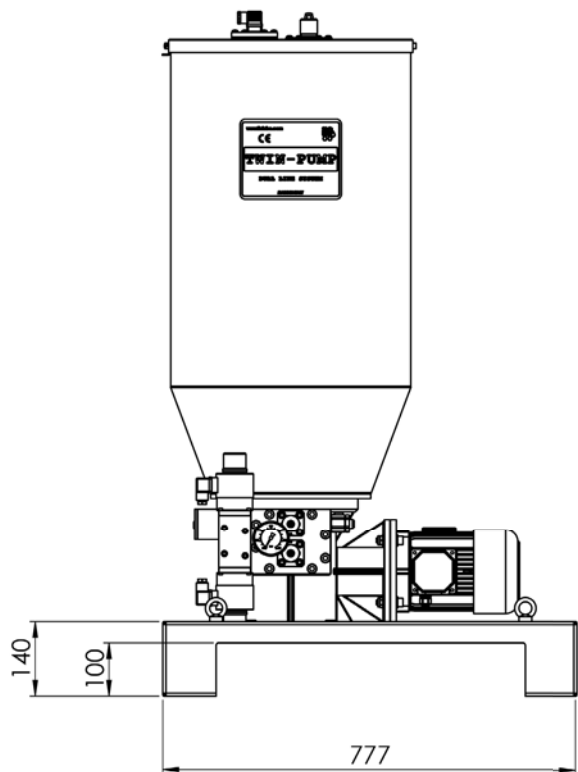

TWIN-PUMP Ordering code configurator

| 55 | . | G | . | 10 | . | S S | . | 5 | . | S | . | 2 | . | A | . | X |

A
B
C
D
E
F
G
H
I

A (Lubricants)

Grease	G
Oil	O

B (Reservoir)

Painted steel

100 kg	10
30 kg	03

SS316L

100 kg	10X
30 kg	03X

C (Drive motor)

Three phase Code

230/ 400V 50 HZ	S
280/ 480V 60HZ	S
460 V 60 Hz	H
380 V 60 Hz	F
575 V 60 Hz	D
500 V 50 Hz	E
550 V 50 Hz	G

Single phase Code

115 V AC 60 Hz	B
230 V AC 50 Hz	C

No motor	X
----------	---

D (Marking)

IE2 IP-65	S
UL-CSA	U
NEMA	N

E (Reversing valve)

Electro-mechanical

Voltage	Code
24 V DC	1
115 V AC	2
230 V AC	3

Pneumatic

Voltage	Code
24 V DC	4
24 V AC	5
115 V AC	6
230 V AC	7

Hydraulic

9

No reversing valve

X

F (Min level indicator)

Capacitive sensor	S
Ultrasonic sensor (grease)	C
No level	X

G (Max level indicator)

Capacitive sensor	2
Ultrasonic sensor (grease)	c
No level	X

H (Heat module)

No module (standard)	A
with heat module	B

I (Support)

Steel box IP-65	1
Box SS316L	2
Pallet	X
No pallet	0

Mini Twin-pump

Technical data



Functioning principle	electrically operated piston pump
Operating pressure	max 350 bar
Lubricant output	25 cm ³ minute
Safety valve	adjustable from 50 to 400 bar default set 300 bar
Main line connection	3 / 8" BSP
Reversing valve	electric, pneumatic o hydraulic
Protection class	IP-65
Drive motor	0,18 Kw

Suitable lubricant	Oil Min. 50 cSt Grease Max NLGI-2 (DIN 51818)
Reservoir capacity	10 kg or 30 kg
Reservoir loading (oil)	filling cap with 300 micron filter
Reservoir loading (grease)	1/2" BSP check valve
Pressure gauge	0 – 400 bar
Mounting position	vertical
Unit box (steel/SS316.L)	protection IP-65
Humidity	90% max
Operating temperature	-25° C +80° C

Height and weight

Reservoir	Weight	Total Height
30 kg	42 kg (vuoto)	889 mm
10 kg	36 kg (vuoto)	638 mm

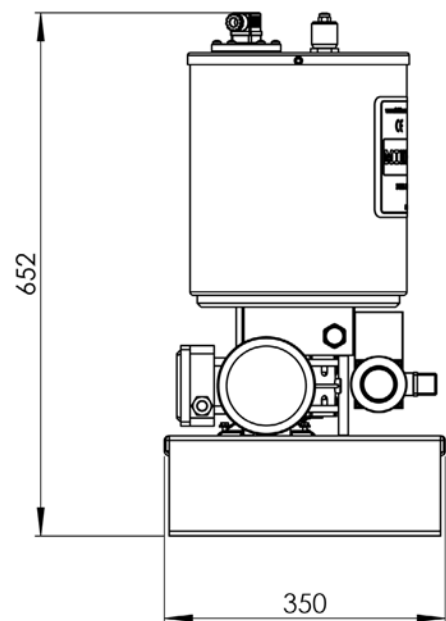
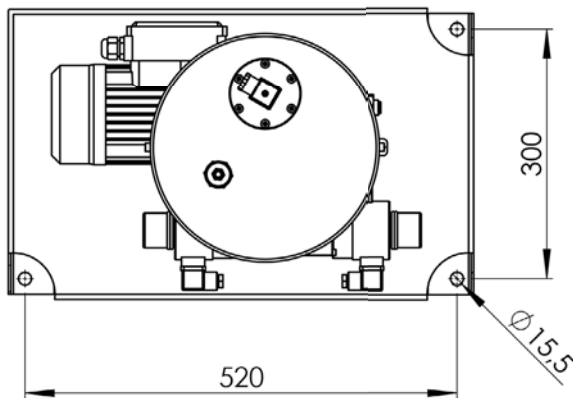
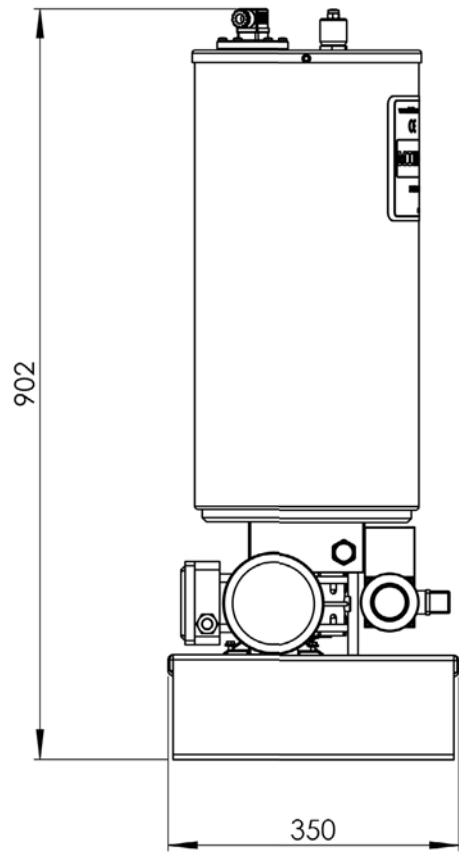
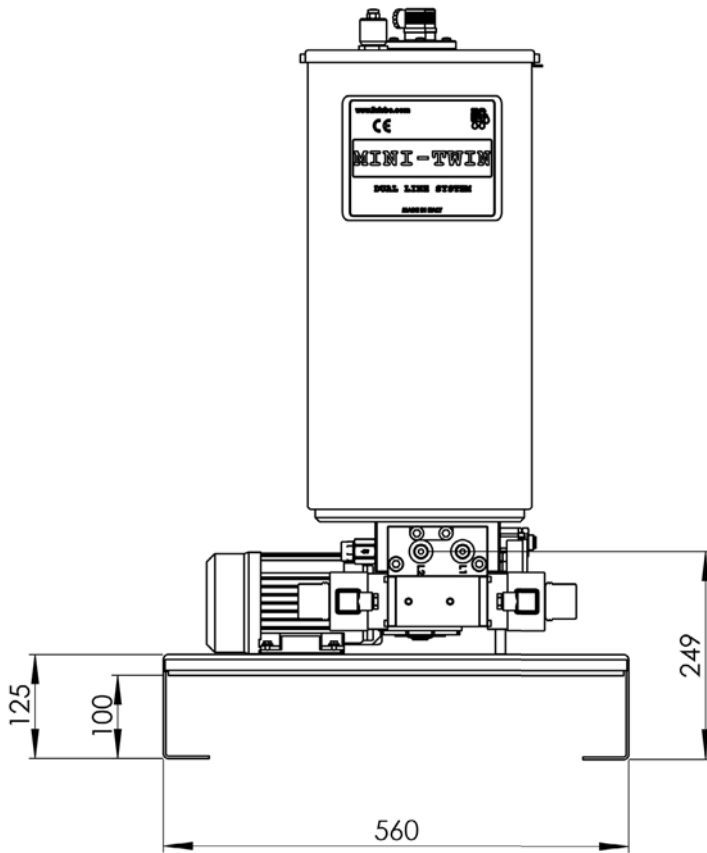

Mini TWIN-PUMP ordering code configurator

| 57 | . | G | . | 10 | . | S S | . | 5 | . | S | . | 2 | . | A | . | X |

A
B
C
D
E
F
G
H
I

A (Lubricants)

Grasso	G
Olio	O

B (Reservoir)

Painted steel

10 kg	01
30 kg	03

SS316L

10 kg	01X
30 kg	03X

C (Drive motor)

Three phase Code

230/ 400V 50 HZ	S
280/ 480V 60HZ	S
460 V 60 Hz	H
380 V 60 Hz	F
575 V 60 Hz	D
500 V 50 Hz	E
550 V 50 Hz	G

Single phase Code

115 V AC 60 Hz	B
230 V AC 50 Hz	C

No motor	X
----------	---

D (Marking)

IE2 IP-65	S
UL-CSA	U
NEMA	N

E (Reversing valve)

Electro-mechanical

Voltage	Code
24 V DC	1
115 V AC	2
230 V AC	3

Pneumatic

Voltage	Code
24 V DC	4
24 V AC	5
115 V AC	6
230 V AC	7

Hydraulic

9

No reversing valve

X

F (Min level indicator)

Capacitive sensor	S
Ultrasonic sensor (grease)	C
No level	X

G (Max level indicator)

Capacitive sensor	2
Ultrasonic sensor (grease)	c
No level	X

H (Heat module)

Non presente (standard)	A
Presente	B

I (Support)

Box Acciaio IP-65	1
Box SS316L	2
Pallet	X
No pallet	0

Drive motor



TWIN and Mini TWIN pumps come with a standard configuration featuring a three phase motor.

It can be configured and provided with 115 V AC, 230 V AC 50/60 Hz single phase motors or special tension ones.

Three phase

Supply voltage	Frequency	Absorption
230 V / 400 V	50 Hz	3.08 A / 1.78 A
275 V / 480 V	60 Hz	3.08 A / 1.78 A

Single phase

Supply voltage	Frequency	Absorption
230 V AC	50 Hz	5,1 A
230 V AC	60 Hz	5,61 A
115 V AC	50 Hz	10,2 A
115 V AC	60 Hz	11,2 A

Twin Pump motor

Power	0.75 kW
Protection degree	IP55
Service	S1 (continuous)
Insulation	Class F
Construction form	B5
Size	Mec80
Weight	11.2 Kg

Three phase

Supply voltage	Frequency	Absorption
230 V / 400 V	50 Hz	0,68 A
275 V / 480 V	60 Hz	0,68 A

Single phase

Supply voltage	Frequency	Absorption
230 V AC	50 Hz	1,47 A
230 V AC	60 Hz	1,61 A
115 V AC	50 Hz	2,94 A
115 V AC	60 Hz	3,2 A

Mini Twin-pump motor

Power	0.18 kW
Protection degree	IP55
Service	S1 (continuous)
Insulation	Class F
Construction form	B3/B14
Size	Mec63

Visual

for grease



Every pump equips the visual sensor as standard. It is meant to check the maximum grease level.

As the floater raise, the visual pin raise aswell, showing the maximum grease level has been reached..

Pump	Reservoir	Min	Max
TWIN	100-30 Kg	-	A70.094154
Mini TWIN	30-10 Kg	-	A70.094154

Capacitive sensor

for grease

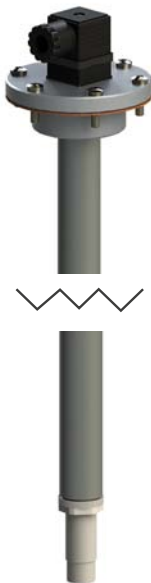

Capacitive sensor can be installed for both minimum and maximum grease level control.

Within the configurator you can select both the minimum and maximum control code.

Pump	Reservoir	Min	Max
TWIN	100 Kg	A70.094155	A70.094157
TWIN	30 Kg	A70.094156	A70.094157
Mini TWIN	30 Kg	A70.094168	A70.094170
Mini TWIN	10 Kg	A70.094169	A70.094170

Ultrasonic sensor

for grease



They measure the delta time of a train wave reflected on the lubricant surface inside the reservoir.

They offer good precision and measuring does not rely on grease consistency.

Pump	Reservoir	Continuous
TWIN	100-30 Kg	A70.094158
Mini TWIN	30 Kg	A70.094167

Reed sensor

for oil



Capacitive sensor can be installed for both minimum and maximum oil level control.

Within the configurator you can select both the minimum and maximum control code.

Pump	Reservoir	Min	Max
TWIN	100 Kg	A70.094160	A70.094162
TWIN	30 Kg	A70.094161	A70.094162
Mini TWIN	30 Kg	A70.094171	A70.094173
Mini TWIN	10 Kg	A70.094172	A70.094173

Electro-mechanical reversing valve

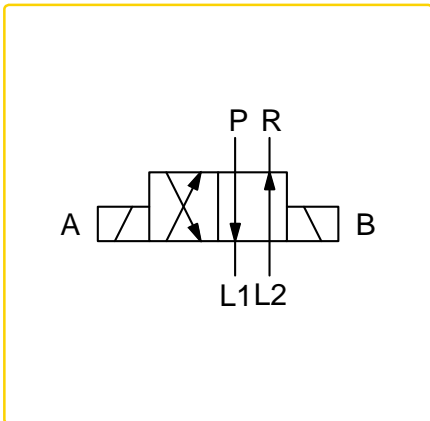

for pump

Assembled	Reversing valve	Block
55.IEM10.115V	55.IEM10.V.115V	A51.082195
55.IEM10.230V	55.IEM10.V.230V	A51.082195
55.IEM10.24DC	55.IEM10.V.24DC	A51.082195

for line

Assembled	Reversing valve	Block
55.IEM10.115V.L	55.IEM10.V.115V	A51.082217
55.IEM10.230V.L	55.IEM10.V.230V	A51.082217
55.IEM10.24DC.L	55.IEM10.V.24DC	A51.082217

Technical data

Max delivery (oil 100 cSt)	40 L/Min
Max working pressure	400 Bar
Lubricants	Grease Max. NLGI 2
Voltage	24 V DC / 24 V AC - 50/60 Hz 115 V / 230 V AC - 50/60 Hz
Weight	12 kg
Working temperature	-30° C ÷ + 80° C
Humidity	90%
Protection degree	IP-55
Inlets / outlets	G3/8" BSP

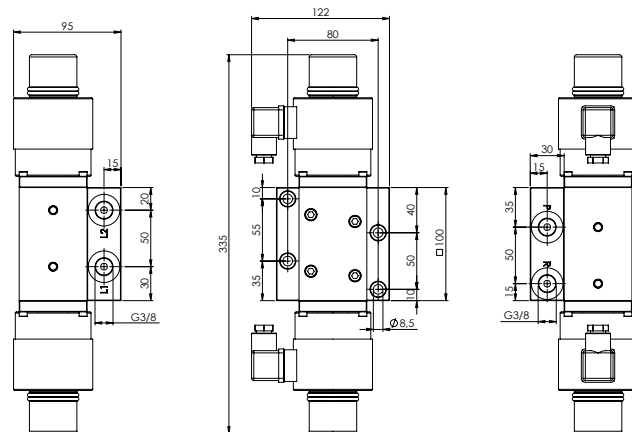

Line reversing valve measures

Pneumatic reversing valve

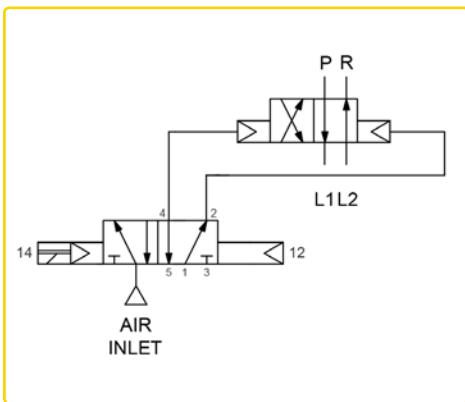

		for pump	
Assembled	Reversing valve	Block	
55.IEP10.115V	55.IEP10.V.115V	A51.082195	
55.IEP10.230V	55.IEP10.V.230V	A51.082195	
55.IEP10.24AC	55.IEP10.V.24AC	A51.082195	
55.IEP10.24DC	55.IEP10.V.24DC	A51.082195	

		for line	
Assembled	Reversing valve	Block	
55.IEP10.115V.L	55.IEP10.V.115V	A51.082217	
55.IEP10.230V.L	55.IEP10.V.230V	A51.082217	
55.IEP10.24AC.L	55.IEP10.V.24AC	A51.082217	
55.IEP10.24DC.L	55.IEP10.V.24DC	A51.082217	

Technical data

Max delivery (oil 100 cSt)	40 L/Min
Max working pressure	400 Bar
Lubricants	Grease Max. NLGI 2
Voltage	24 V DC / 24 V AC - 50/60 Hz 115 V / 230 V AC - 50/60 Hz
Weight	11 kg
Working temperature	-30° C ÷ + 70° C
Humidity	90%
Protection degree	IP-55
Inlets / Outlets	G3/8" BSP

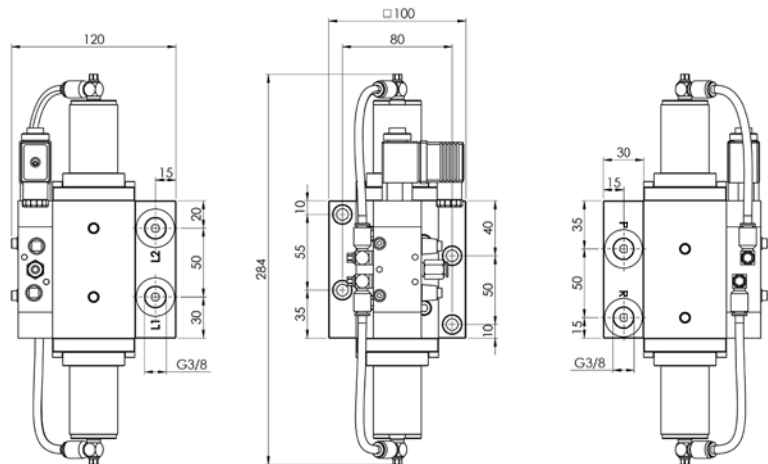

Line reversing valve measures

Hydraulic reversing valve

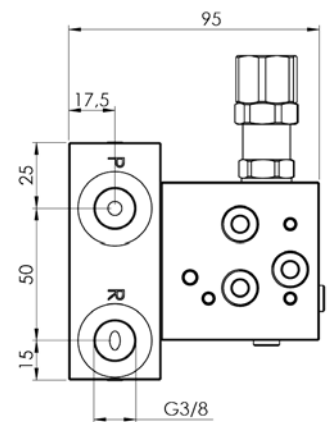
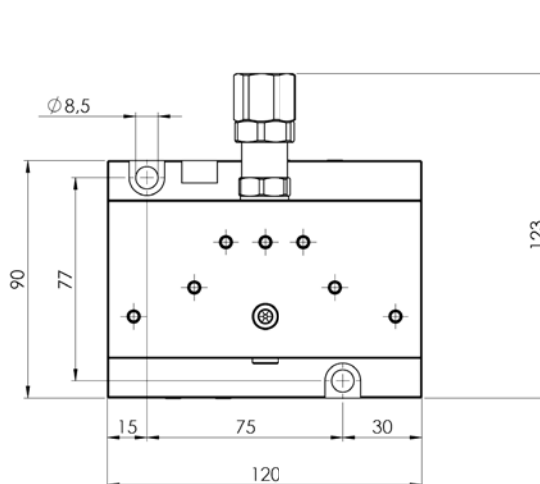
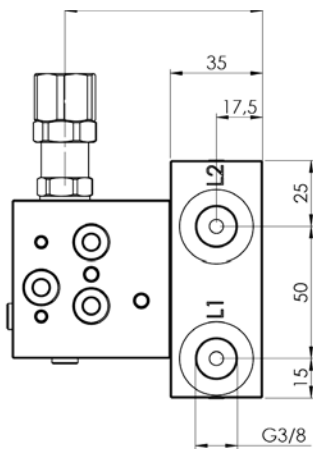
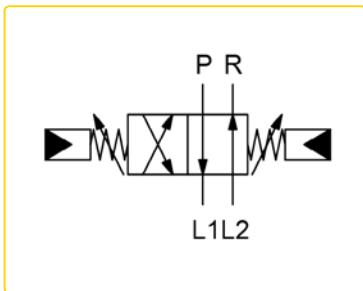

for pump

Assembled

Reversing valve

Block

55.ISP10

55.ISP10.V

A51.082216

for live

Assembled

Reversing valve

Block

55.ISP10.L

55.ISP10.V

A51.082218

Technical data

Max delivery (oil 100 cSt)	400 cc/Min
Pressure adjustment	50÷300 Bar – Setting 250 Bar
Max working pressure	300 Bar
Lubricants	Grease Max. NLGI 2
Working temperature	-25° C + 70° C
Humidity	90%
Protection degree	IP-55
Inlets / Outlets	G3/8" BSP