

lubrication systems



MIXER X

MIXING VALVES
FOR AIR + OIL LUBRICATION SYSTEMS



General information	3
Operation	4
Technical data	5
Overall dimensions	6
Compressed air and Connections	7
Fittings and Configurator	8
Metering device codes	9



All ILC products must only be used for their intended purposes, as specified in this brochure and in all instructions. If the product is supplied together with user instructions, the user is required to read them and comply with them. Not all lubricants are suitable for centralised lubrication systems. ILC lubrication systems or relative components cannot be used together with gas, liquid gas, pressurised gas in solution and liquids with vapour pressure exceeding normal atmospheric pressure (1013 bar) by more than 0.5 bar, maximum temperature permitted. Any type of dangerous materials, namely those classified as such by European Community Directive (EC) 67/548/EEC, Article 2 (2), can only be used in ILC centralised lubrication systems or relative components upon consultation with ILC and after having received written approval from the company.

General information

MIXER-X valves are air-oil mixers complete with high precision volumetric metering devices. They are structured in individual elements that can be assembled up to a maximum of 8 elements (for blocks with a greater number of utilities, consult our technical office).

The head elements RH (right) and LH (left), which include the seats for air and oil supply, are located at the ends.

Metering can be selected for each lubrication point within a range between 10 and 160 mm³/cycle.

In addition to the metering unit, an air flow adjustment screw is provided in Mixer X.

The piping connections for the main and secondary line are available with quick fittings or with compression fittings and are used with pipes with a diameter of 6 or 8 mm (main line) and 4 or 6 mm (secondary line). The MIXER-X.C model combines the characteristics described above with real control of the lubricant flow, from the metering unit to the mixing chamber, and is available for flow rates from 10 to 30 mm³/cycle.

The cycle control consists of a PMM block installed directly in the mixer body. A proximity sensor and a control piston, driven directly by the lubricant flow, are housed inside it.

Each circuit operation corresponds to a movement of the piston which generates a change of state of the sensor. Any anomaly preventing piston movement triggers an alarm. The alarm will be present during start-up if there are air bubbles in the circuit and will continue to apply until complete de-aeration.

Applications

- Lubrication of bearings, specifically electric spindle bearings.
- Transmission system lubrication.
- Sliding guide and rack lubrication.
- Lubrication during assembly and processing.

Advantages

- Higher performance of the bearings thanks to higher speed indexes.
- Greater operational safety thanks to constant supply with pre-defined quantity of lubricant. The air protects the bearing against external impurities.
- Less lubricant for greater protection of the environment.
- Accurate and constant metering suitable to the requirements of individual lubrication points.
- Approximately 70% reduction in lubricant consumption compared to traditional lubrication.

AIR+OIL system operation

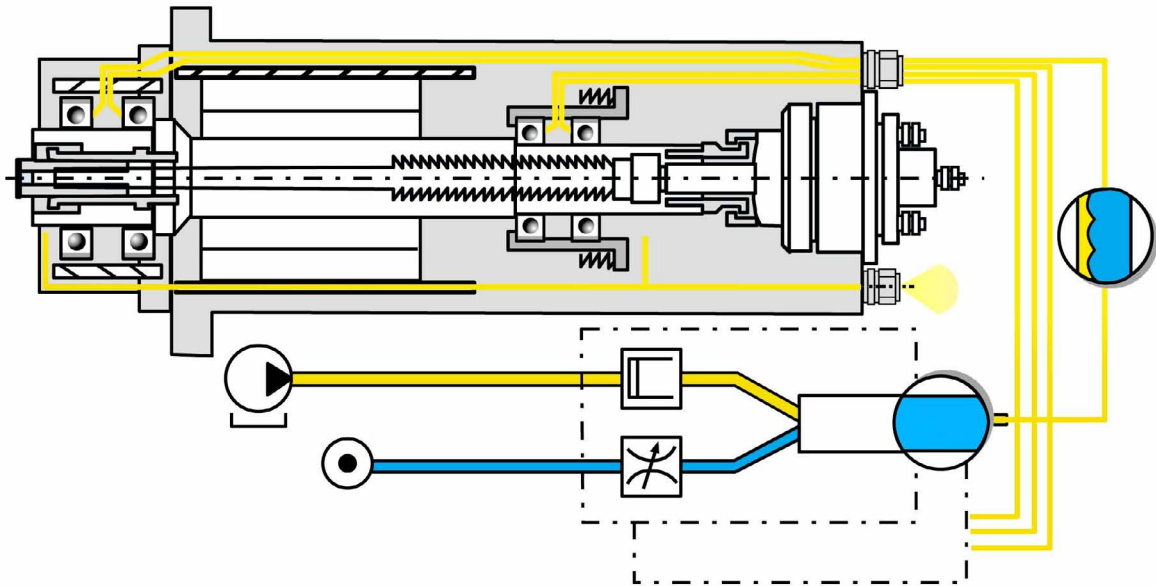

Air/oil lubrication systems base their operating principle on the breakdown of a drop of oil sent inside a small diameter flexible pipe, where it forms an oil film adhering to the inner wall of the pipe. By means of the air flow, the oil is gradually sent to the point to be lubricated.

By suitably sizing the length of the pipe (1 m minimum) and the oil metering, a continuous delivery of lubricant microdroplets is obtained, projected onto the point to be lubricated which, once it is reached, retains the oil, letting the air flow exit freely without creating any pollution problem for the environment. The cooling effect of the air flow, in addition to keeping the bearing temperature at a minimum, generates a slight overpressure that prevents any external impurities from penetrating inside.

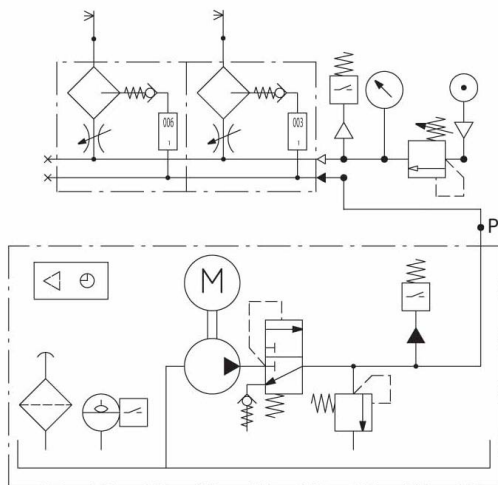

System with electric pump

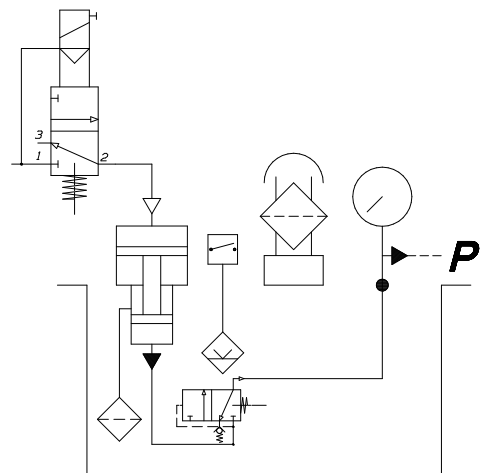

System with pneumatic pump

Technical data

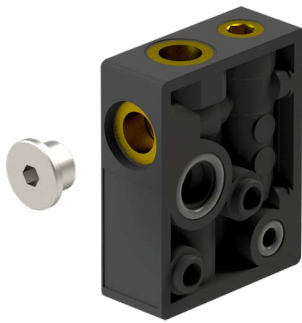

Metering	10 – 20 – 30 60 – 100 -160 mm ³ /cycle
Metering precision	± 10% standard ± 5% High Precision
Number of cycles/minute	Max 5
Oil inlet	1/8 BSP
Air inlet	1/8 BSP
Air-oil outlets	1/8 BSP
Oil supply pressure	Min 18 – Max 40 bar
Air supply pressure	Min 3 – Max 10 bar
Operating temperature	5 – 80°C
Internal seals	NBR or FPM
Lubricants	Oil with viscosity from 16 to 220 cSt
Flow control model	
Fixing screws	M5x50
Body material	PARA-IFEX FG50%

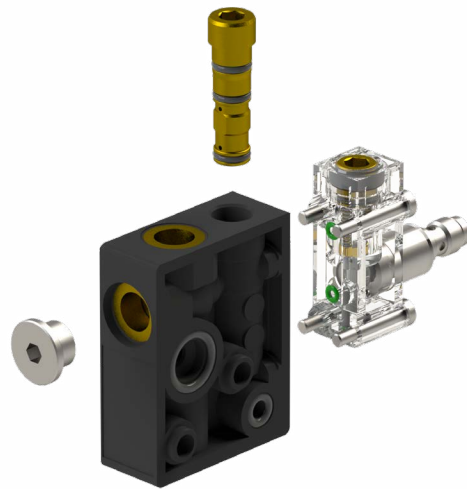

Control inductive element

Sensor Type	PNP NO inductive
Voltage	6-30 V DC
Output current	Max 200 mA
Current	< 22 mA
Temperature	-25°C +70°C
Protection	Ip-67
connection	M8x1
Block body material	PET-G

Compact pressure gauge

46.700.9

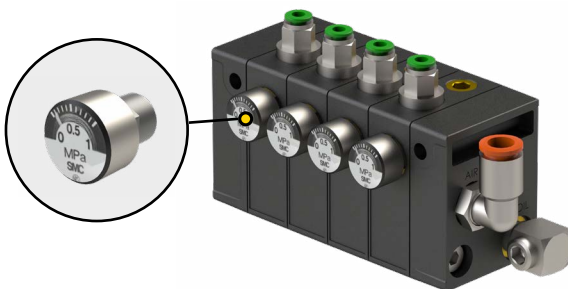

Reading pressure	0-10 bar
Thread	1/8" BSP conical
Diameter	15 mm

Overall dimensions

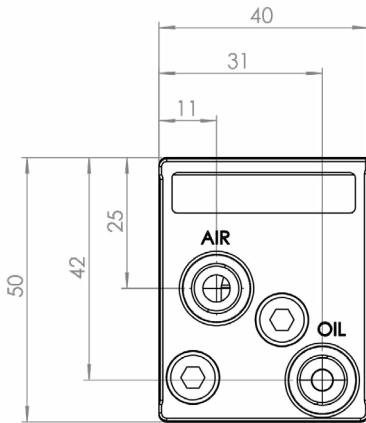

Without Control inductive element

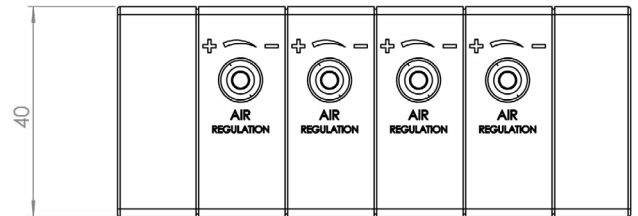
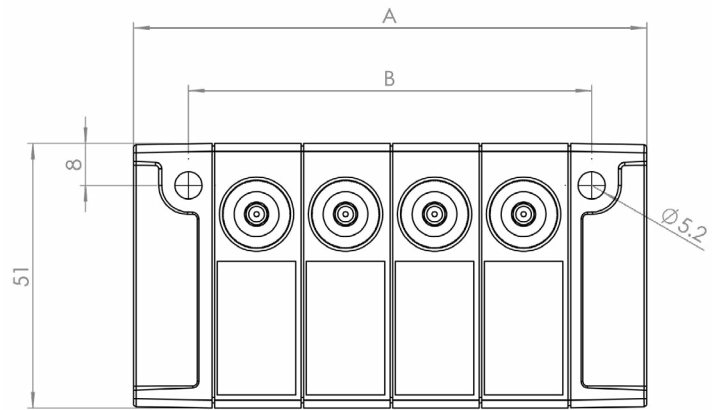
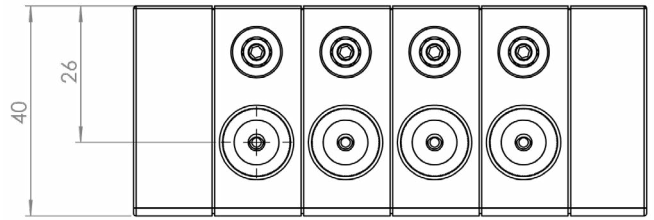

Model with control

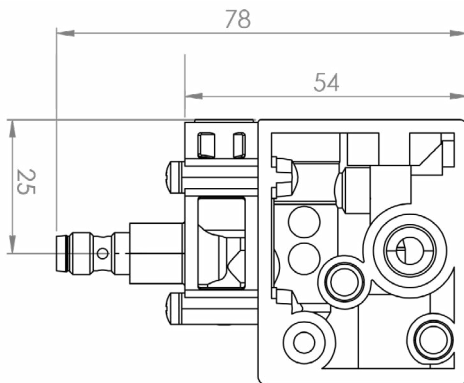

Elements	A	B
1	47	26
2	64	43
3	81	60
4	98	77
5	115	97
6	132	111
7	149	128
8	166	145

Compressed air supply

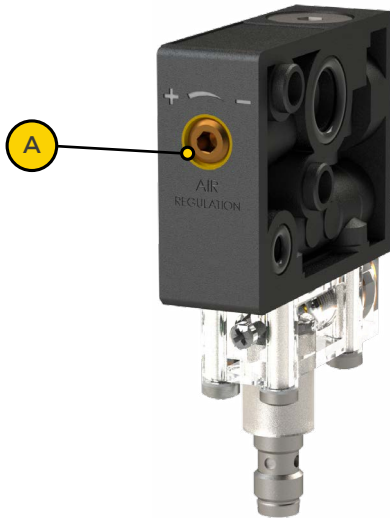

Use of a $< 3 \mu$ regulator – dehumidifier filter is recommended, so as to feed dry and filtered air into the system. A pressure of at least 3 bar is required at the mixer inlet.

The amount of air required to project the oil into a pipe with an internal diameter of 3 mm ranges between 1,200 and 1,500 l/h. This value can be applied by using lubricants with a viscosity from ISO VG 16 up to ISO VG 100. For oils with higher viscosity or with greater adhesive power, higher values must be calculated.

It is possible to adjust the air pressure for each individual line with a ch3 key, by turning the screw (A) in the indicated direction (+/- see table below).

Approximate mixer outlet air flow values

Inlet Air	+1/4 rotation	+1/2 rotation	+1 rotation	+2 rotations	+3 rotations
3 Bar	1.0 l/m	3.5 l/m	10.0 l/m	22.0 l/m	33.0 l/m
4 Bar	1.2 l/m	4.2 l/m	12.0 l/m	26.0 l/m	40.0 l/m
5 Bar	1.6 l/m	5.5 l/m	15.0 l/m	33.0 l/m	50.0 l/m
6 Bar	2.0 l/m	7.0 l/m	21.0 l/m	45.0 l/m	58.0 l/m



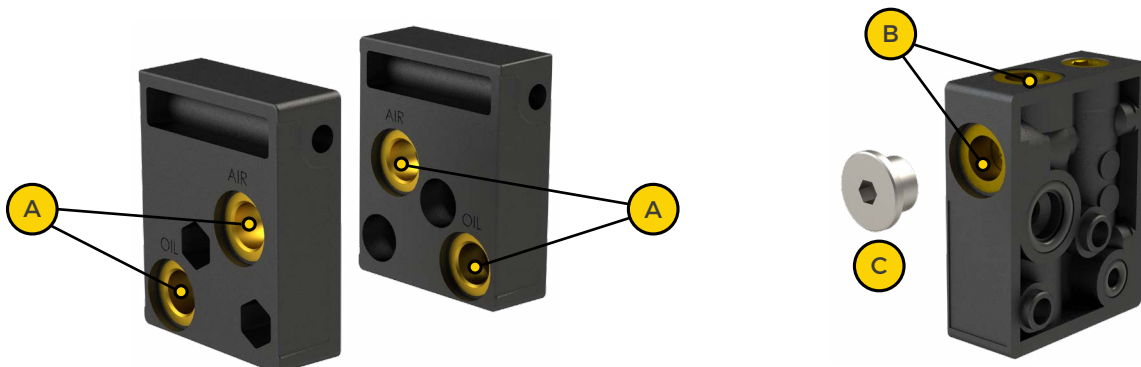

The indicated values refer to a test with a pipe length of 1.5 m and an internal diameter of 3 mm. The rotations are considered starting from the adjustment screw fully closed (-).

Connections





The MIXER-X mixers require an inlet for the air line and one for the oil line in both the head elements (A). The metering element has the option of having the air-oil outlet on 2 different sides of the block (B). The unused outlet must always be closed with the specific cap C (Order code 05.051.0).



Main line G 1/8" BSP

Push-In	Code	Ø Pipe	Figure	CH	Ogive	Code	Ø Pipe	Figure	CH
	A92.106665	6	straight	12		TW.100502	6	straight	12
	A92.106666	8	straight	14		TW.100503	8	straight	14
	A92.106667	6	90°	12		TW.102002	6	90°	12
	A92.106668	8	90°	12		TW.102003	8	90°	14

Secondary Line G 1/8" BSP

Push-In	Code	Ø Pipe	Figure	CH	Ogive	Code	Ø Pipe	Figure	CH
	A92.106714	4	straight	10		TW.100501	4	straight	10
	A92.106665	6	straight	12		TW.100502	6	straight	12
	A92.106437	4	90°	12		TW.102001	4	90°	10
	A92.106667	6	90°	12		TW.102002	6	90°	12

Order code configurator



A (Element Number)	B (Seals)		D (Metering Device Model)	
1	NBR	N	Standard	S
2	FPM	V	Control	C
3	C (Metering)		E (Precision)	
4	10	A	Standard	G
5	20	B	High precision	H
6	30	C		
7	60	D		
7	100	E		
8	160	F		

Individual Metering Device Codes



Standard

Standard	With Cycle control	Metering
02.909.12.010	02.909.12.010.C	10 mm ³
02.909.12.020	02.909.12.020.C	20 mm ³
02.909.12.030	02.909.12.030.C	30 mm ³
02.909.12.060	-	60 mm ³
02.909.12.100	-	100 mm ³
02.909.12.160	-	160 mm ³

High Precision

Standard	With Cycle control	Metering
02.909.12.010.H	02.909.12.010.C.H	10 mm ³
02.909.12.020.H	02.909.12.020.C.H	20 mm ³
02.909.12.030.H	02.909.12.030.C.H	30 mm ³
02.909.12.060.H	-	60 mm ³
02.909.12.100.H	-	100 mm ³
02.909.12.160.H	-	160 mm ³

Head Element Codes

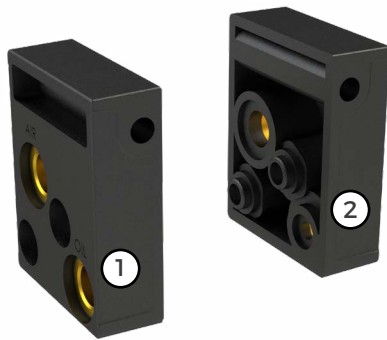

MiXER-X Blocks

Code	Position	Fig.
A62.093775	RH Block	1
A62.093776	LH Block	2

Tie Rod Codes



Code Element No.

Code	Element No.
MX.TR.01	1
MX.TR.02	2
MX.TR.03	3
MX.TR.04	4
MX.TR.05	5
MX.TR.06	6
MX.TR.07	7
MX.TR.08	8