

lubrication systems



# DPL

**Monoblock progressive dividers**

High quality and high tolerance  
Unbeatable combination of performance and  
convenience

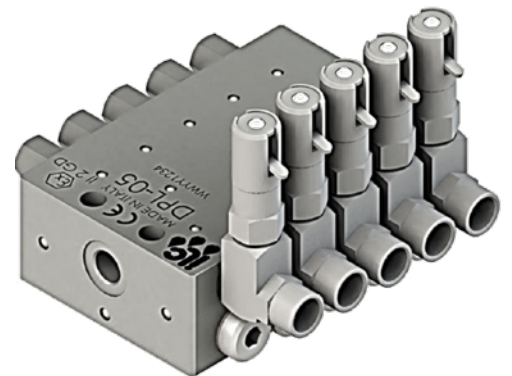

# TABLE OF CONTENTS

Description	3	Shut-Off valve	10
Technical data	4	Cycle control	11
Outlets	5	Inductive control (ATEX)	12
Ordering Codes	8	Memory sensor	13
Junctions	9	Connection fittings	14

## Features and general description

The DPX system doses lubricant with a progressive piston movement. Every piston controls the following one in a sequence obtained through a single delivery flow.

This system is highly qualified for dosing oil and grease to one or more journals or bearing. Each piston is in series with the component before or the one after it and therefore malfunctioning of one of these causes stopping of the sequence and consequently inhibiting of the system.

This inhibition occurs also during any external clogging or when unused outlet are plugged.

In order to check the entire distribution process, it is enough to apply a single visual or electrical control.

The pump flowrate is fractionable when the doser blocks are arranged in cascade. A master block can supply one or more progressive doser. Those doser can, in turn, supply another block of dosers.

It is recommended to have no more than two cascades after the master for compressibility and aerations reasons. Any further addition can cause irregular flow, especially using grease or low flow rates.

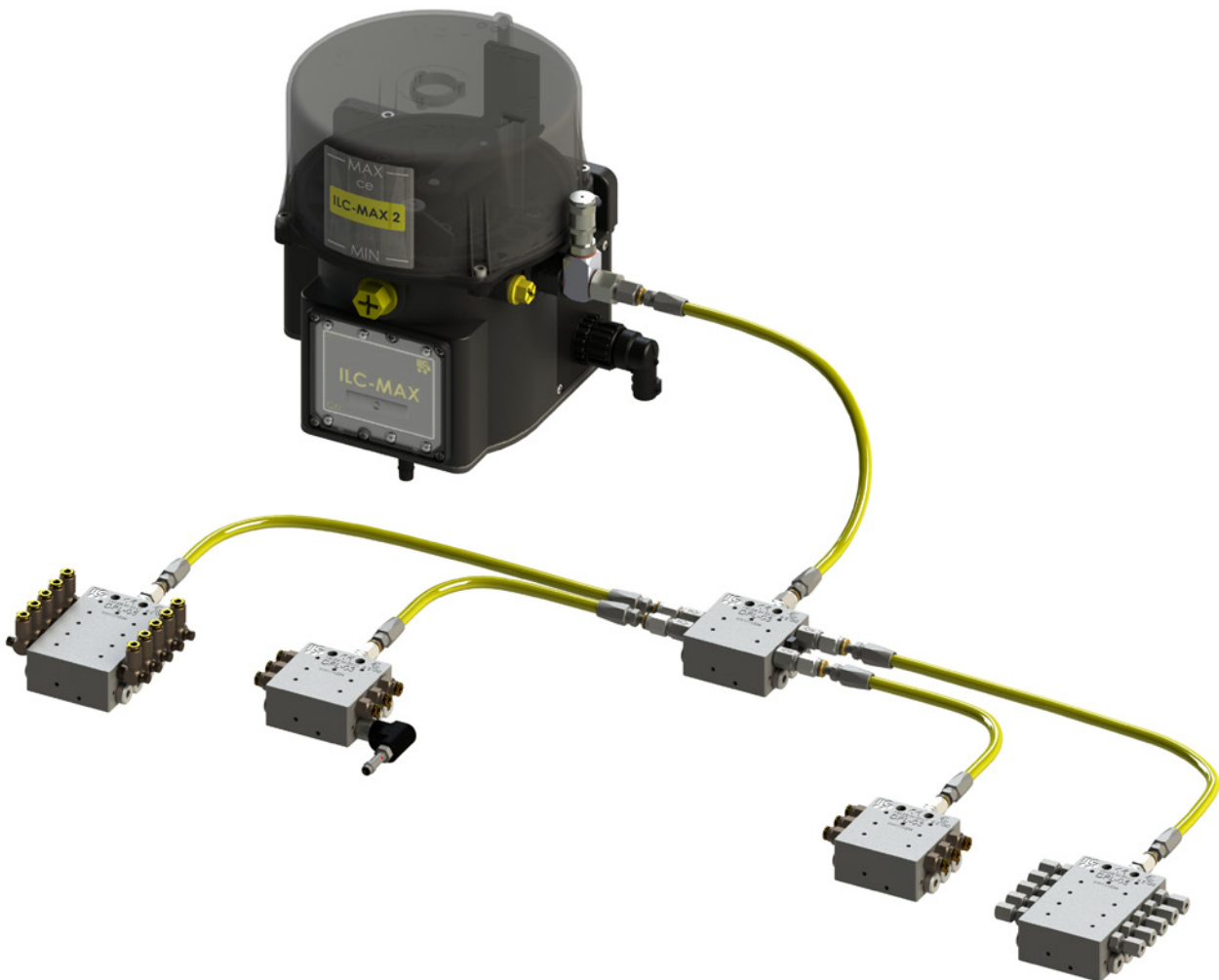

Dpl progressive dividers advantages

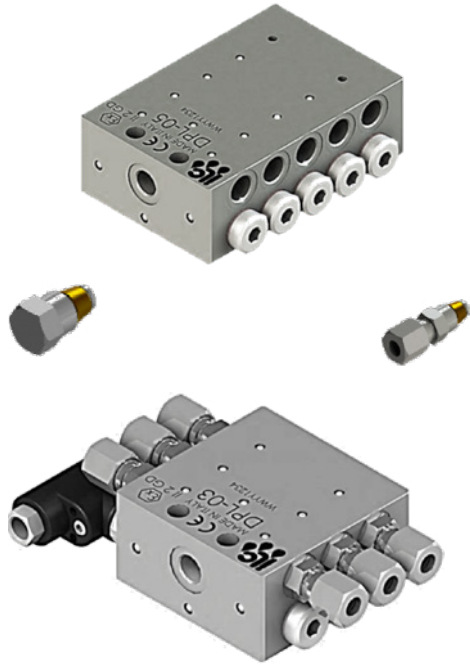

Standard inlet check valve

Easier configuration with less pistons

Even possible to close one of the two outputs

Two different ways to join outlets

Plug for conveying in the next output

Separation screw for one single outlet

Technical data

Operating pressure	From 15 to 300 Bar
Lubricants (at minimum operating temperature)	Mineral oil minimum 46 cSt or Grease maximum NLGI-2
Operating temperature	From -40 °C to 110 °C
Discharge (for outlet)	200 mm <sup>3</sup> /cycle
Inlet port	1/8" BSP
Check valve	Standard in the inlet
Outlet port	M10x1
Outlets	from 6 to 20
Piston cycles	Max 350/min
Coating	Zinc-Nickel plated
Marking	ATEX II GD - CE
Metering devices	Steel, Zn-Ni plated (free of Cr-VI)

Outlets How to join/separate outlets

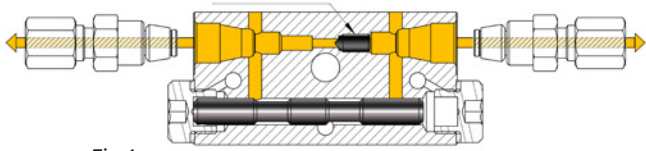

Fig.1

One separation dowel (FIG.1) divides the lubricant through the two outlets. In order to have just one outlet with the double discharge remove the dowel and close one of the outlet with the plug (FIG.2).

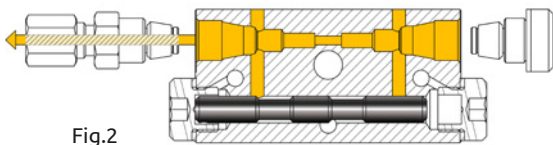

Fig.2

Uscite Somma delle portate

Using the cap 05.026.1 the lubricant is conveyed into the outlet below. In the example (fig 3) the cap is used in the outlet **C** and the lubricant is conveyed to the outlet **E**, likewise a cap on the outlet **G** which conveys the lubricant to **I**.

The plugs in series in the outputs **D**, **F** and **H** convey the lubricant to the outlet **L**.



For solutions involving a combination of plugs 05.026.0 and 05.026.1 it is necessary to contact the ILC technical office.

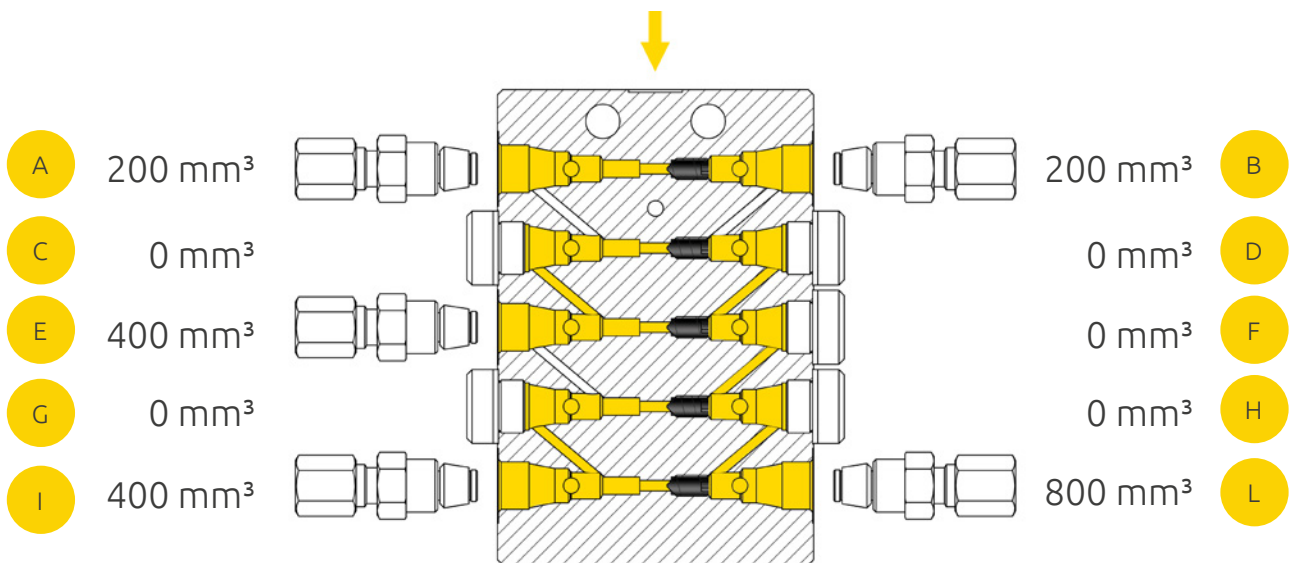
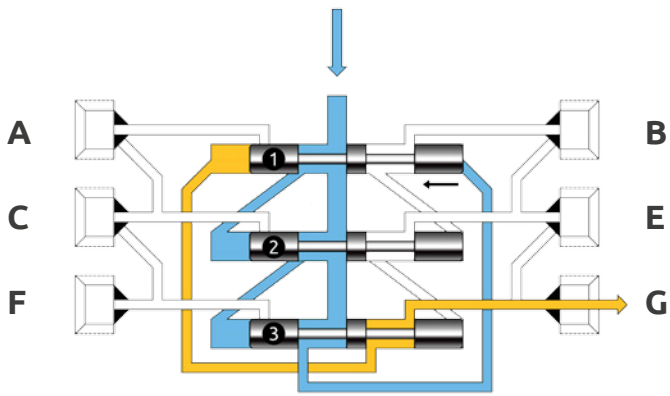
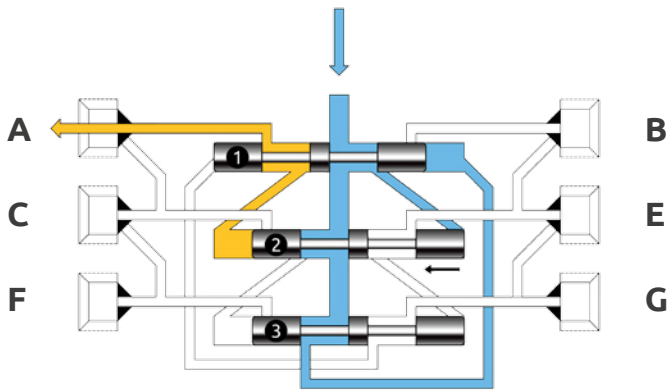

Fig.3



A

Lubricant flow pressure (blue) moves piston **1** to the left allowing lubricant discharge (yellow) from **G**.



B

When piston **1** reaches its limit, lubricant flow pressure (blue) operates on piston **2**. Lubricant volume (yellow) discharge from **A**.

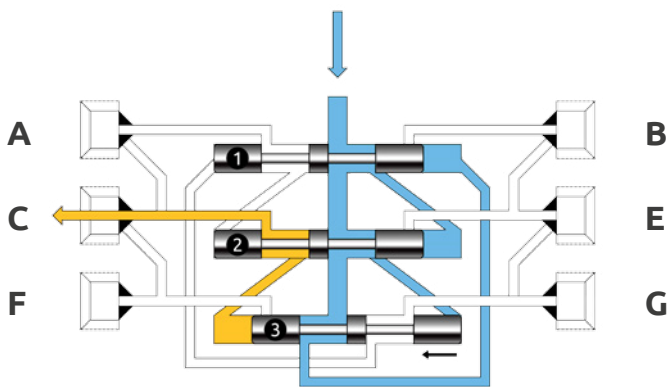

C

When piston **2** reaches its limit, lubricant flow pressure (blue) operates on piston **3**. Lubricant volume (yellow) discharge from **C**.

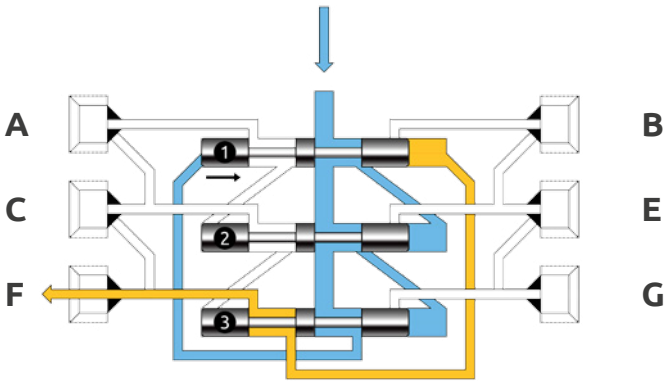

D

When piston **3** reaches its limit, lubricant flow pressure (blue) operates on piston **1**. Lubricant volume (yellow) discharge from **F**.

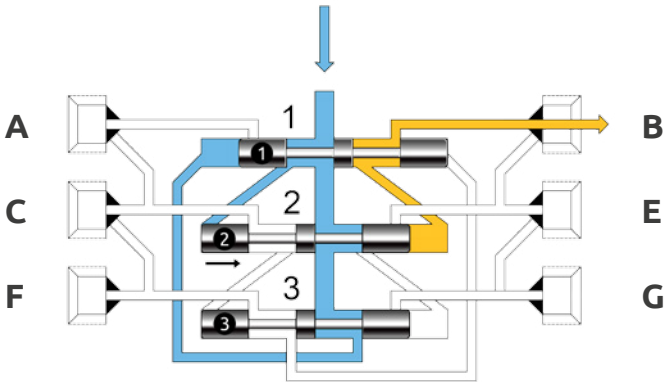

E

When piston **1** reaches its limit, lubricant flow pressure (blue) operates on piston **2**. Lubricant volume (yellow) discharge from **B**.

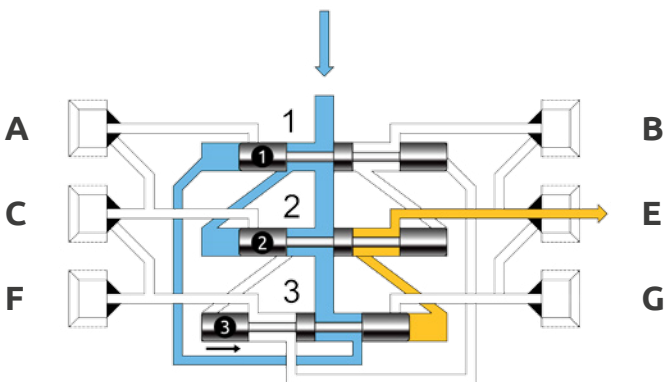

F

When piston **2** reaches its limit, lubricant flow pressure (blue) operates on piston **3**. Lubricant volume (yellow) discharge from **E**. The system is ready for a new cycle.

Monoblock progressive divider

Ordering codes



Outlets	Standard	With visual pin
6	4.1N.03	4.2V.03
8	4.1N.04	4.2V.04
10	4.1N.05	4.2V.05
12	4.1N.06	4.2V.06
14	4.1N.07	4.2V.07
16	4.1N.08	4.2V.08
18	4.1N.09	4.2V.09
20	4.1N.10	4.2V.10

With inductive sensor		
Outlets	M8x1	M12x1
6	4.3I.8.03	4.3I.12.03
8	4.3I.8.04	4.3I.12.04
10	4.3I.8.05	4.3I.12.05
12	4.3I.8.06	4.3I.12.06
14	4.3I.8.07	4.3I.12.07
16	4.3I.8.08	4.3I.12.08
18	4.3I.8.09	4.3I.12.09
20	4.3I.8.10	4.3I.12.10

Dimensions

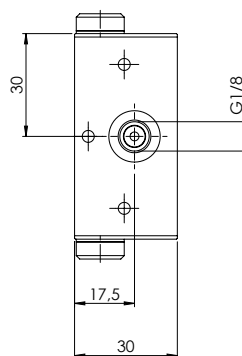
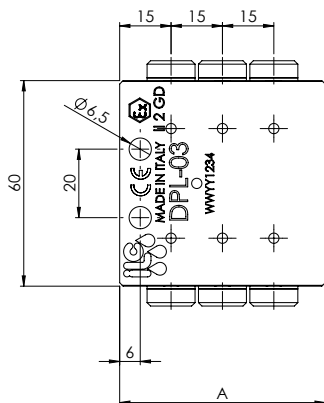

Outlets	A[mm]
6	60
8	75
10	90
12	105
14	120
16	135
18	150
20	165



**BANJO with grease nipple**

03.355.5/ 03.355.6



Banjo junctions are placed on a progressive distributor inset. Their job is to let us use a manual or hidraulic pump when the main pump does not work.

Code	Thread
03.355.5	1/8" BSP (inlet)
03.355.6	M10 x 1 (outlet)

**Inset filter**

07.261.1/07.261.3

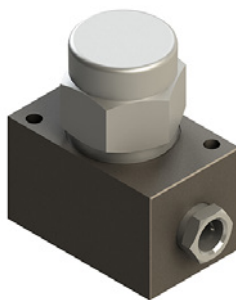

These strainer prevent the lubricant lines from being obstructed by impurities.

Plug **1/4" BSP (F)**

Codice	Filtration rate
07.261.1	300 $\mu$
07.260.3	125 $\mu$

**Inset filter 70  $\mu$**

07.270.5

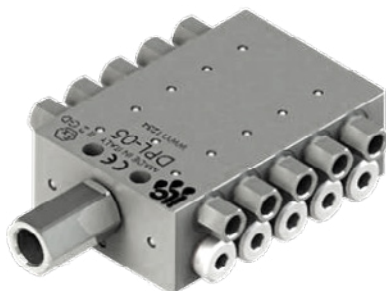

These strainer prevent the lurbricant lines from being obstructed by impurities.

Filtration rate **70  $\mu$**   
Plug **1/4" BSP (F)**

**ORDERING CODE 07.270.5**

Shut-Off EV-2

A70.093688/115/230

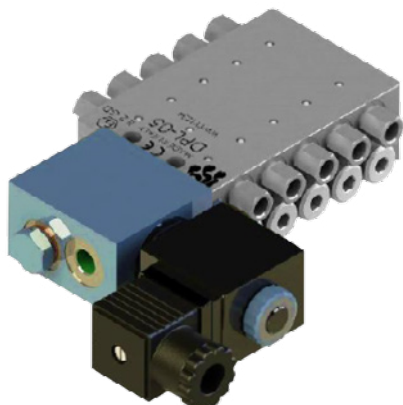

SHUT OFF valves EV-2 are made of a special “NC” 2-ways solenoid valve and of a modular base that can be directly assembled on the DPL inlet.

**EV-2** valve is the essential element in order to transform a standard progressive system into a **sectioned system**.

Ordering codes

Code	Voltage
A70.093687	24 V DC
A70.093687.115	115 V AC
A70.093687.230	230 V AC

Technical data

Pressure	Max 300 Bar
Lubricant	Oil min viscosity 32 cSt Grease max NLGI-1
Temperature	Da -20 °C a +80 °C
Voltage	24 V DC, 115 - 230 V AC 50/60 Hz.
Power	35 W (DC) 8 VA (AC)
Protection	IP54
Inlet	1/8" BSP

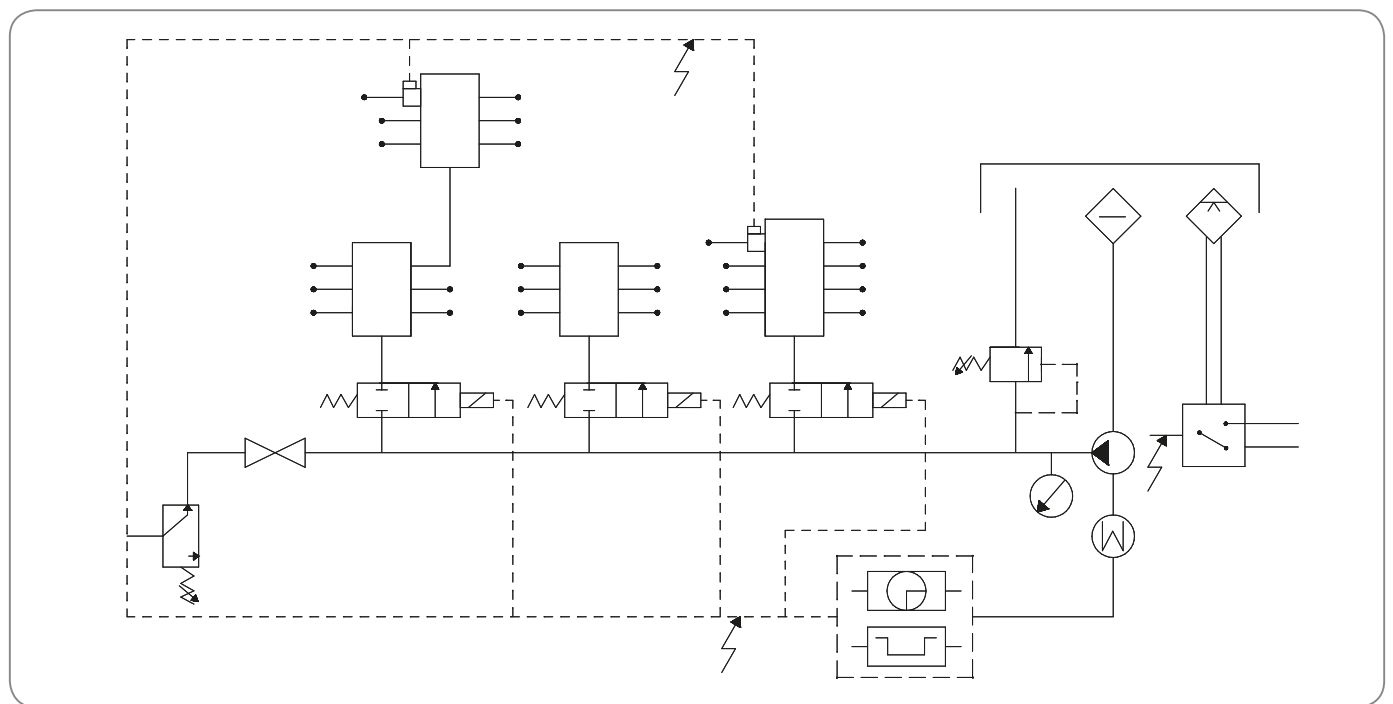

Visual pin



The visual pin shows the piston movement, monitoring the proper operation of the entire system.

Inductive control



In this control a proximity switch is housed in a composite block.

The piston opens and closes the contact as it moves into its operational seat.

They are usually used in cycle control systems where they can count up to 300 movement for minute.

Electrical Data

Voltage	6-30 V DC
Outlet current	Max 200 mA
Current	< 22 mA
Operating temperature	from - 25 °C to +70 °C
Protection	IP 67
Sensor housing	Stainless steel
Sensor block	Pet-G
Connection	M8x1 - M12x1

Connection cable codes

Length	M8x1 Straight	M12x1 90°	M12x1 Straight
5 m	A91.111227	A91.111441	A91.111349
10 m	A91.111348	A91.111552	A91.111296
15 m	A91.111393	A91.111553	A91.111350

Electrical connection

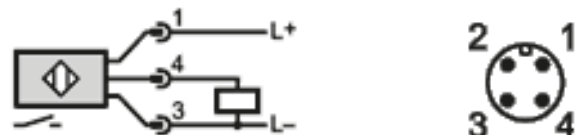

Sensor kit codes

M8x1	49.053.1
M12x1	49.053.2

Group II Category 1D-1G/2G

Electrical data

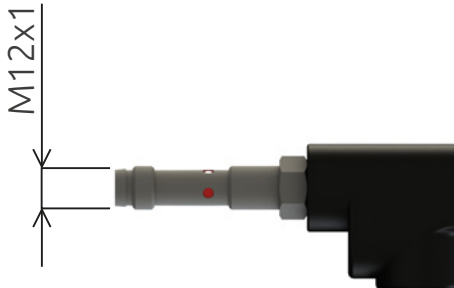

Electrical Model	Certified intrinsically safe circuits with maximum values $U = 15\text{ V} / I = 50\text{ mA} / P = 120\text{ mW}$
Nominal voltage	8,2 DC; (1k $\Omega$ )
Voltage	V 7,5...30 DC; to be used outside potentially explosive areas
Current	< 1 blocker; (> 2,1 mA conductore)
Contact	NC
Current capacity [MA]	< 30; to be used outside potentially explosive areas
Temperature	-20...70
Protection	IP 67

Ordering codes

Electrical connection

Inductive control	49.053.2.ATX.1GD
Connection cable (2 m)	A91.111519
Connection cable (10 m)	A91.111520

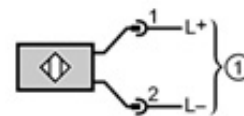

Group II Category 3G-3D

Electrical data

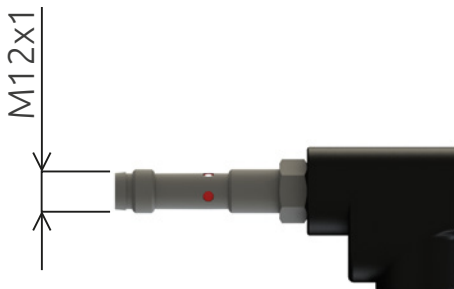

Electrical Model	DC PNP
Nominal voltage	10-36 V DC
Outlet current	MAX 200 mA
Current	< 20 Ma
Temperature	da - 40 °C a + 70 °C
Protection	IP 67
Sensor housing	Stainless steel
Contact	NO

Ordering codes

Electrical connection

Inductive control	49.053.2.ATX
Connection cable (2 m)	A91.111519
Connection cable (10 m)	A91.111520

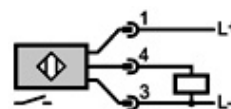

Pressure pin indicator (with memory)

09.710.2...7

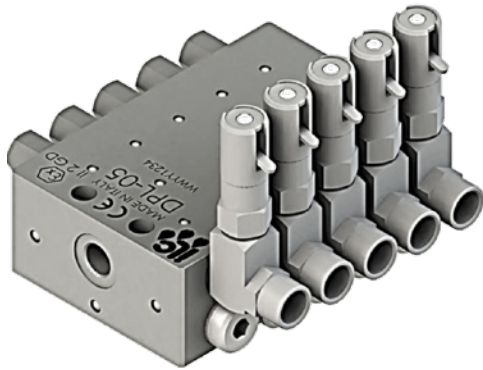

These indicators are usually for overpressure control on primary and secondary lines.

In the eventuality of a pressure higher than expected, the pin indicator moves out. It remains in position until the release lever is manually actuated.



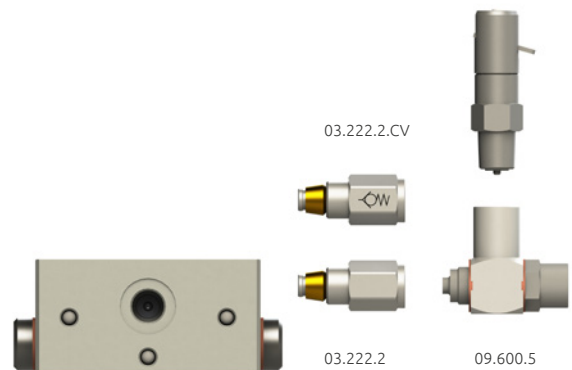

We suggest to discover the reason and the location of the fault before actuating the lever.

Ordering codes

Code	Pressure	Code	Pressure
09.710.2	50 Bar	09.710.5	150 Bar
09.710.3	75 Bar	09.710.6	200 Bar
09.710.4	100 Bar	09.710.7	250 Bar



In order to connect pressure sensor we need 03.222.2 or 03.222.2.CV adaptor and a T junction (09.600.5)

Inlet connections			Outlet connections		
<b>DIN 2353</b>	Pressure	Thread	<b>DIN 2353</b>	Pressure	Thread
	315 bar	1/8 BSP		250 bar	M10 x 1
<b>Straight</b>	Code	Ø Tube	<b>Straight</b>	Code	Ø Tube
	TW.100504	6 mm		03.222.1.04	4 mm
	TW.100525	8 mm		03.222.1.06	6 mm
	TW.100528	10 mm			
<b>90°</b>	Code	Ø Tube	<b>Check valve</b>	Code	Ø Tube
	TW.102004	6 mm		14.052.0	6 mm
	TW.102025	8 mm			
	TW.102028	10 mm			
<b>PUSH-IN</b>	Pressure	Thread	<b>PUSH-IN</b>	Pressure	Thread
	250 bar	1/8 BSP		250 bar	M10 x 1
<b>Straight</b>	Code	Ø Tube	<b>Straight</b>	Code	Ø Tube
	03.256.0	6 mm		03.255.3.N	4 mm
				03.256.3.N	6 mm
<b>90°</b>	Code	Ø Tube	<b>90°</b>	Code	Ø Tube
	03.256.6	6 mm		03.255.8 N	4 mm
				03.256.7 N	6 mm
			<b>Check valve</b>	Code	Ø Tube
				03.256.3 NCV	6 mm
			<b>Male nut - Olive</b>	Male nut	Ø Tube
				04.016.0	6 mm
				Olive	Ø Tube
				06.016.0	6 mm
<b>Outlet Adaptors</b>	Pressure	Thread	<b>Outlet plug</b>	Pressure	Thread
	350 bar	M10 x 1 M/F		350 bar	M10 x 1 M/F
	Standard			Next outlet lubricant conveying	
	03.222.2			05.026.1	
	Check Valve			Same piston opposite side conveying	
	03.222.2.CV			05.026.0	

**Inlets**

Any kind of fitting can be installed on the inlet thread 1/8 BSP.

**Outlets**

The M10x1 Outlet thread accept only ILC fittings with sealing cone.

In order to use standard fittings, adaptors 03.222.2 or 03.222.2.CV are required.