

DROPS NOT LITERS!

MINIMAL
LUBRICATION
SYSTEMS



GOCCE
NON LITRI!



IMPIANTI
LUBRIFICAZIONE



Kortrijkstraat 187 B-8770 Ingelmunster
Tel. +32 (0)51 316 205 - Fax +32 (0)51 309 621 info@pomac.be - www.pomac.be

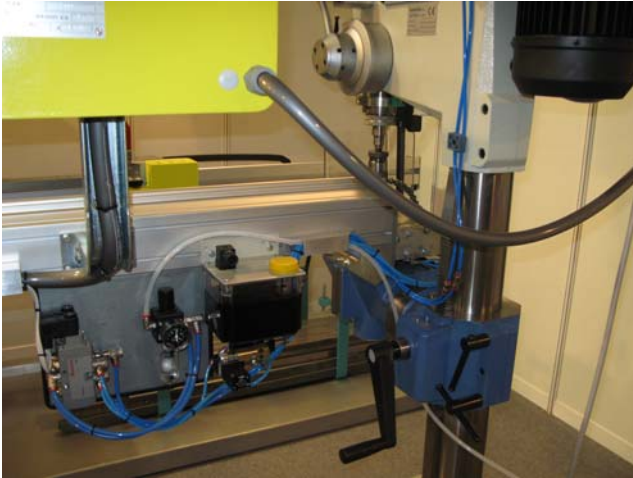

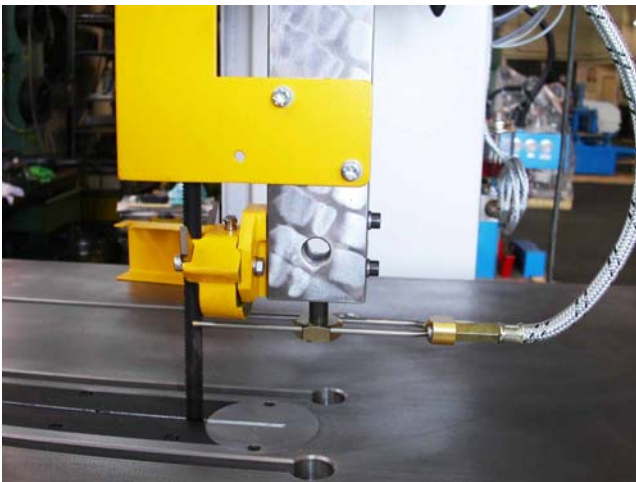

INDICE	INDEX	PAGINA PAGE
INTRODUZIONE	<i>INTRODUCTION</i>	4
APPLICAZIONI	<i>APPLICATIONS</i>	5
PRINCIPALI VANTAGGI	<i>MAIN ADVANTAGES</i>	6
PRINCIPIO DI FUNZIONAMENTO	<i>WORKING PRINCIPLE</i>	7 – 9
UNITA' UCFG, UCGF-SE, AGGF, AGGF-SE, UCSG, UCSG-SE, AGSG E AGSG-SE	<i>UNITS UCFG, UCGF-SE, AGGF, AGGF-SE, UCSG, UCSG-SE, AGSG E AGSG-SE</i>	11 – 25
UNITA' MC-EL-3P-4P-5P-6P-7P, MC-EL-3M-4M-5M-6M-7M, MC-EL-2P, MC-EL-2M, MINI-GF-EL, MINI-GF, MINI-SG-EL, MINI-SG, MINI-035-WFG E MINI-035-FG	<i>UNITS MC-EL-3P-4P-5P-6P-7P, MC-EL-3M-4M-5M-6M-7M, MC-EL-2P, MC-EL-2M, MINI-GF-EL, MINI-GF, MINI-SG-EL, MINI-SG, MINI-035-WFG E MINI-035-FG</i>	26 – 43
UNITA' MIX	<i>UNIT MIX</i>	44 – 47
TUBI COASSIALI	<i>COAXIAL FEELING LINES</i>	48
TERMINALI CON UGELLO	<i>END TUBES WITH NOZZLE</i>	49 – 52
UGELLI A SELLA PER SEGATRICI A NASTRO	<i>SADDLE NOZZLE FOR BAND SAW MACHINES</i>	53 – 56
UGELLI A SELLA PER SEGATRICI CIRCOLARI	<i>SADDLE NOZZLE FOR CIRCULAR SAW MACHINES</i>	57 – 58
UGELLO PER SEGATRICI VERTICALI	<i>NOZZLE FOR VERTICAL BLADE</i>	59
PASSAPARETE PER TUBO COASSIALE	<i>BULKHEAD CONNECTION FOR COAXIAL HOSE</i>	60
APPLICAZIONI	<i>APPLICATIONS</i>	61 – 70
OLIO VEGETALE	<i>VEGETABLE OIL</i>	71
COMPONENTI	<i>COMPONENTS</i>	72 – 85





INTRODUZIONE

I SISTEMI DI LUBRIFICAZIONE MINIMALE LUBETOOL SONO STATI PROGETTATI PER SOSTITUIRE LA TRADIZIONALE LUBRIFICAZIONE AD EMULSIONE D'OLIO O OLIO INTERO NELLE LAVORAZIONI CON ASPORTAZIONE DI TRUCIOLO, STAMPAGGIO E DEFORMAZIONE A FREDDO.

UTILIZZANO LUBRIFICANTI VEGETALI (A BASE NATURALE) CHE SOSTITUISCONO I TRADIZIONALI FLUIDI ELIMINANDO L'OBBLIGO DI REGISTRAZIONE E SMALTIMENTO DEI LIQUIDI ESAUSTI.

LE MICRO POMPE PNEUMATICHE DOSANO DELLE MINIME QUANTITA' DI LUBRIFICANTE CHE SONO TRASPORTATE DA UN FLUSSO DI ARIA COMPRESSA VERSO IL PUNTO DI CONTATTO UTENSILE/PEZZO SENZA CREARE NEBBIA O INQUINAMENTO. IL LUBRIFICANTE E' CONSUMATO DURANTE LA FASE DI LAVORAZIONE.

SI OTTIENE UN IMMEDIATO INCREMENTO DELLA PRODUTTIVITA' IN QUANTO VENGONO ELIMINATI I TEMPI DERIVATI DALLA PULIZIA DELLA MACCHINA, DELLA ZONA DI LAVORO E DEI PEZZI.

UN ULTERIORE VANTAGGIO NELLA RIDUZIONE DEI COSTI E' DERIVATO DALL'INCREMENTO DELLA DURATA DELL'UTENSILE CHE ,MANTENUTO AD UNA TEMPERATURA AMBIENTE AUMENTA DRASTICAMENTE LA SUA VITA.

SI ELIMINANO INOLTRE I PROBLEMI DI SALUTE DERIVATI DAL CONTATTO CON I FLUIDI TRADIZIONALI.

INTRODUCTION

THE ILC MICRO-LUBRICATION SYSTEMS ARE DESIGNED FOR USE PRIMARILY IN THE VARIED METAL CUTTING AND FORMING PROCESSES TO ENABLE THE REPLACEMENT OF FLOOD AND WATER-SOLUBLE COOLANTS.

DUE TO THE WAY THE SYSTEMS DELIVER A PRECISE MINIMAL QUANTITY OF HEAVIER THAN AIR LUBRICATING OIL DROPLETS TO THE CUTTING EDGE VIA INDIVIDUALLY ADJUSTABLE PNEUMATIC PUMPS THERE IS NO MISTING EFFECT IN THE ATMOSPHERE. NO GENERATION OF FRICTION / HEAT BETWEEN THE WORK SURFACE AND THE TOOL CUTTING EDGE, AND THE LUBRICATING OIL IS CONSUMED IN THE MACHINING PROCESS.

JUST A SMALL QUANTITY OF OIL DOES THE JOB AND HE IS NATURALLY CONSUMED IN THE CUTTING PROCESS, SO THERE IS NO HARMFUL MISTING OR HAZARDOUS WASTE DISPOSAL TO WORRY ABOUT AND THAT CAN MEAN HIGHER PRODUCTIVITY, SINCE YOU DO NOT SPEND TIME CLEANING PARTS OR DISPOSING OF USED COOLANTS.

THEY PREVENT HEAT BUILD-UP AND CONTROL HEAT DISTORTION, SO YOU GET A TRUER CUT AND CLEANER MACHINE OPERATION. SINCE TOOLS AND PARTS STAY AT ROOM TEMPERATURE DURING CUTTING OPERATION, TOOL LIFE IS DRAMATICALLY INCREASED AND MAINTENANCE AND REPLACEMENT COSTS ARE REDUCED. REDUCED HANDLING AND STORAGE OF HAZARDOUS MATERIALS MEANS A SAFER, CLEANER WORKING ENVIRONMENT. AND CLEAN-UP IS EASY, USING JUST SOAP AND HOT WATER (160 °F / 70 °C).

VANTAGGI

- AMBIENTE DI LAVORO PULITO**
- MAGGIORE PRODUTTIVITA'**
- INCREMENTO DELLA DURATA DELL'UTENSILE**
- MIGLIORE FINITURA DELLE SUPERFICI**
- RIDUZIONE DEI COSTI**
- MIGLIORAMENTO DELLE TOLLERANZE DI LAVORAZIONE**
- RIDUZIONE DEL CONSUMO DI LUBRIFICANTE DEL 90%**
- ELIMINAZIONE DELLE OPERAZIONI DI SMALTIMENTO DEI LIQUIDI ESAUSTI**
- TRUCIOLI ASCIUTTI**
- RIDUZIONE DEI TEMPI DI FERMO MACCHINA**
- INCREMENTO DELLA PRODUTTIVITA'**
- IMMEDIATO AMMORTAMENTO DELL'ACQUISTO**

ADVANTAGES

- A CLEANER SAFER WORKING ENVIRONMENT**
- HIGHER PRODUCTIVITY**
- INCREASED TOOL LIFE**
- BETTER SURFACE FINISH**
- COST REDUCTION**
- THE ABILITY TO MACHINE TO HIGHER TOLERANCES**
- LUBROREFRIGERANT CONSUMPTION REDUCTION 90% LOWER**
- NO COOLANT HANDLING OR DISPOSAL PROBLEMS**
- DRY CHIPS (SWARF)**
- LESS MACHINE DOWN TIME**
- INCREASED PRODUCTIVITY**
- SHORT PAY BACK TIME**



APPLICAZIONI

APPLICATIONS

RISULTATI OTTIMI SONO STATI RAGGIUNTI NELLE SEGUENTI
APPLICAZIONI

PROVEN RESULTS IN THE FOLLOWING PRIMARY APPLICATIONS

SEGATRICI A NASTRO



BAND SAWING

SEGATRICI A DISCO



CIRCULAR SAWING

FRESATURA



MILLING

INCISIONE



ENGRAVING

FILETTATURA – MASCHIATURA



TAPPING

ALESATURA



BORING



FORATURA



DRILLING

BROCCIATURA



BROACHING

AFFILATURA UTENSILI



TOOL AND CUTTER GRINDING

RULLATURA



ROLLING

DENTATURA



GEAR CUTTING

PIEGATURA



BENDING

PUNZONATURA



PUNCHING

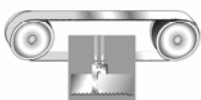

CALIBRATURA – PROFILATURA



ROLLFORMING

CURVATURA TUBI

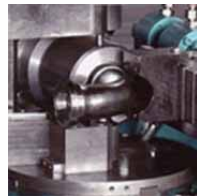

PIPES BENDING

STAMPAGGIO A FREDDO



STAMPING

TORNITURA A LASTRA



METAL SPINNING

NASTRI E COILS



BELTS AND COILS

CONVOGLIATORI AEREI



MONO AND BI-RAILS CONVEYORS

CATENE



CHAINS

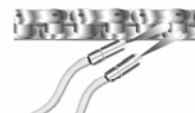



LUBRIFICAZIONE SETTORE ALIMENTARE



FOOD MACHINERY

SPRUZZATURA RIVESTIMENTI PROTETTIVI



PROTECTING COATING SPRAY

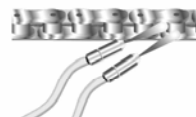
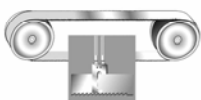

PRINCIPALI VANTAGGI DEL SISTEMA LUBETOOL

THE UNIQUE ADVANTAGES OF LUBETOOL

IL SISTEMA LUBETOOLS REGOLA ED EROGA DELLE ESATTE QUANTITA' DI LUBRIFICANTE DA 0 MM³ A 41 MM³.

LUBETOOLS REGULATE THE LUBRICANT SUPPLIED IN EXACT QUANTITIES ADJUSTABLE FROM 0 MM³ TO 41 MM³ – NO GUESSWORK.

DOSAGGIO ED EROGAZIONE EFFETTUATI MEDIANTE UNA MICRO – POMPA A COMANDO PNEUMATICO A SEMPLICE EFFETTO.

100% PNEUMATICALLY CONTROLLED POSITIVE DISPLACEMENT PUMPS.

IL LUBRIFICANTE E' SPRUZZATO CON ESTREMA PRECISIONE TRAMITE UN FLUSSO D'ARIA ED UN UGELLO DI PROIEZIONE VERSO IL PUNTO DI CONTATTO. SONO ELIMINATE ATOMIZZAZIONI E NEBBIE D'OLIO.

LUBRICANT IS CARRIED BY AIR, WITH PINPOINT ACCURACY. HAZARDOUS ATOMIZING AND "MIST" ARE ELIMINATED.

LA PORTATA DEL LUBRIFICANTE PUÒ ESSERE REGOLATA INDIPENDENTEMENTE FRA I VARI PUNTI DI UTILIZZO.

ALL PUMPS AND NOZZLE OPERATE INDEPENDENTLY FOR LUBRICANT.

POSSONO ESSERE INSERITE DELLE MICROPOMPE AGGIUNTIVE IN QUALUNQUE MOMENTO. E' SUFFICIENTE ORDINARE IL KIT DI ASSIEME.

ADDITIONAL PUMPS CAN BE ADDED IN THE FIELD. JUST ORDER A COMPLETE PUMP ASSEMBLY.

L'INSTALLAZIONE IN MACCHINARI PRE-ESISTENTI RICHIEDE DELLE MINIME MODIFICHE DEI SISTEMI DI COMANDO. IN MOLTI CASI NON E' RICHIESTA ALCUNA MODIFICA.

MINIMAL OR NO EQUIPMENT MODIFICATION IS REQUIRED FOR SYSTEM INSTALLATION.

UN GENERATORE DI FREQUENZA PNEUMATICO PERMETTE L'IMPOSTAZIONE DEI CICLI DI FREQUENZA.

A PNEUMATIC TIMING DEVICE (FREQUENCY GENERATOR) WITH A CONTROL RANGE.

ESTREMA FACILITA' DI REGOLAZIONE DELL'ARIA E DELLA QUANTITA' DI OLIO.

EASY LUBRICANT AND AIR FLOW ADJUSTMENT.

SERBATOI CON CAPIENZA PREVISTA PER LUNGA DURATA.

DURABLE RESERVOIR.

TUBAZIONI COASSIALI DI MANDATA FORNITE PRE – CABLATE ALL'UNITA' CON LUNGHEZZA STANDARD 5M. LUNGHEZZE DIFFERENTI POSSONO ESSERE FORNITE SU RICHIESTA.

STANDARD HOSE LENGTH IS 5 M. ADDITIONAL HOSE LENGTH AVAILABLE UPON REQUEST.

DISPONIBILITA' DI DIFFERENTI UGELLI.

MULTIPLE NOZZLE TYPES AVAILABLE.

I SISTEMI LUBETOOL LAVORANO PER VOI!

LUBETOOL WILL GET THE JOB DONE FOR YOU!

INCREMENTO DELLA PRODUZIONE.

PRODUCTION RATES WILL INCREASE.

INCREMENTO DELLA VITA DELL'UTENSILE.

TOOL LIFE WILL IMPROVE.

ELIMINAZIONE DI FUMI E PARTICELLE D'OLIO – PEZZI PULITI - TRUCIOLI ASCIUTTI.

HAZARDOUS AIRBORNE PARTICLES, WASTE DISPOSAL HASSLES AND PARTS CLEANING WILL BE ELIMINATED.



**PRINCIPIO DI FUNZIONAMENTO
GOCCE NON LITRI!**

LA MICRO POMPA PNEUMATICA DOSA UNA PICCOLISSIMA QUANTITA' DI LUBRIFICANTE CHE, ATTRAVERSO IL TUBO CAPILLARE INTERNO DELLA TUBAZIONE COASSIALE, ARRIVA ALL'UGELLO DI SPRUZZO. IL LUBRIFICANTE VIENE PRELEVATO DALL'ARIA COMPRESSA CHE LO POLVERIZZA E LO PROIETTA VERSO IL PUNTO DI CONTATTO UTENSILE/PEZZO, FORMANDO UN RIVESTIMENTO SOTTILE SULL'UTENSILE CHE RIDUCE L'ATTRITO GENERATO DALLA LAVORAZIONE.

POMPA PNEUMATICA DOSATRICE

**WORKING PRINCIPLE
DROPS INSTEAD OF LITERS!**

AN ADJUSTABLE POSITIVE DISPLACEMENT METERING PNEUMATIC PUMP DELIVERS A MINIMAL QUANTITY OF LUBRICANT ALONG A CAPILLARY TUBE FITTED INSIDE LENGTH OF THE AIR LINE TO THE NOZZLE HEAD. AT THIS POINT THE LUBRICANT DROPLET IS INTRODUCED INTO THE AIR STREAM AND TRANSPORTED TO THE CUTTING EDGE. THE LUBRICANT FORMS A THIN EVEN COAT ON THE CUTTING EDGE GREATLY REDUCING THE FRICTIONAL HEAT.

POSITIVE DISPLACEMENT METERING PNEUMATIC PUMP

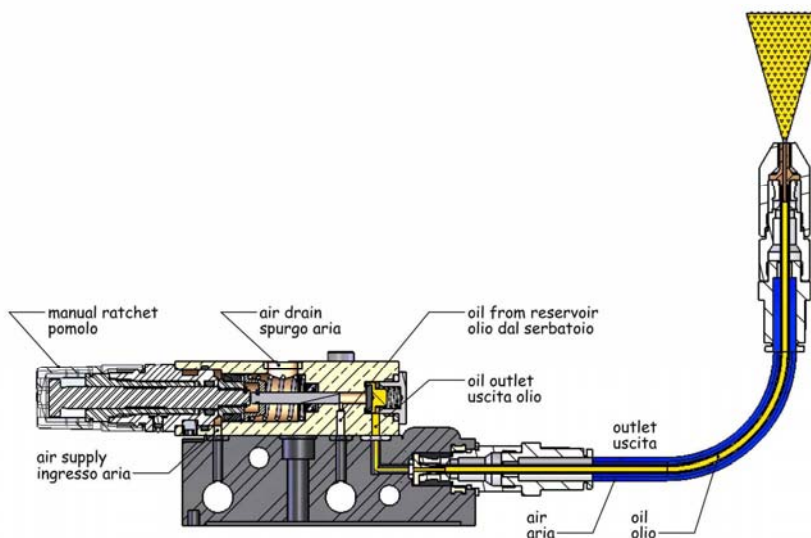

FUNZIONAMENTO

LA POMPA PNEUMATICA A SEMPLICE EFFETTO E' AZIONATA CON UNA PRESSIONE DELL'ARIA DA 5 BAR (75 PSI) A 8 BAR (120 PSI). QUANDO L'ARIA ENTRA NEL CIRCUITO IL PISTONE PNEUMATICO ESEGUE UNA CORSA AZIONANDO IL PISTONCINO IDRAULICO CHE INVIA UNA PREDETERMINATA QUANTITA' DI LUBRIFICANTE ALL' USCITA. QUANDO L'ARIA VIENE TOLTA IL PISTONE TORNA INDIETRO TRAMITE UNA MOLLA, RIEMPIENDO LA CAMERA DI DOSAGGIO ED E' PRONTO PER UNA NUOVA CORSA.

LA FREQUENZA PUO' ESSERE REGOLATA DA 3 COLPI AL SECONDO A 1 AL MINUTO ATTRAVERSO IL GENERATORE DI FREQUENZA E QUESTI VALORI POSSONO CAMBIARE IN BASE AL TIPO DI LUBRIFICANTE UTILIZZATO E ALLA PRESSIONE DELL'ARIA.

LA PORTATA PER CORSA VIENE REGOLATA PER MEZZO DEL POMOLO DA 0 MM³ A 41 MM³

OPERATION

WHEN THE COMPRESSED AIR AT A PRESSURE OF BETWEEN 5 (75 PSI) AND 10 (150 PSI) BAR IS PASSED TO THE PUMP IT ACTS ON THE TOP FACE OF THE PISTON. THE PISTON THEN OPERATES AND A PRECISE SET AMOUNT OF LUBRICANT IS DELIVERED THROUGH THE OUTLET TO THE DELIVERY PORT AND ALONG THE CAPILLARY TUBE. THE AIR IS THEN EXHAUSTED THE PISTON RE-SEATS UNDER SPRING PRESSURE AND THE METERING CHAMBER REFILLS WITH LUBRICANT. THE PUMP IS NOW RESET FOR ANOTHER DELIVERY CYCLE. THE STROKES PER MINUTE CAN BE ADJUSTED BETWEEN 3 EACH SECOND TO 1 EACH MINUTE VIA THE FREQUENCY GENERATOR BUT THESE CAN VARY SLIGHTLY DUE TO THE LUBRICANT USED AND THE AIR PRESSURE

THE LUBRICANT DISCHARGE CAN ALSO BE ADJUSTED BY MEANS OF THE PUMPS MANUAL RATCHET ADJUSTER TO GIVE A DISCHARGE BETWEEN 0 MM³ AND 41 MM³ PER STROKE.



REGOLAZIONE DELLA PORTATA DEL CICLO

RUOTARE IL POMOLO IN SENSO ORARIO PER RIDURRE LA QUANTITA' DI OLIO ED IN SENSO ANTIORARIO PER INCREMENTARLA.

HOW TO ADJUST THE DISCHARGE PER STROKE

TURNING THE ADJUSTER CLOCKWISE WILL DECREASE THE PUMP DISCHARGE AND TURNING THE ADJUSTER ANTI-CLOCKWISE WILL INCREASE THE PUMP DISCHARGE.

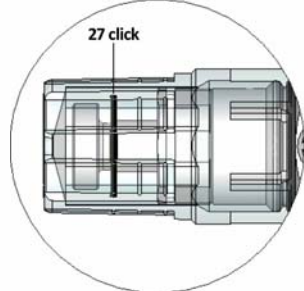
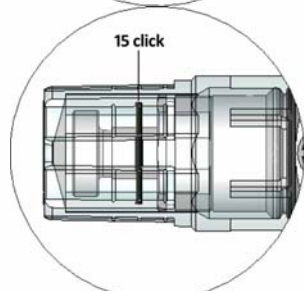
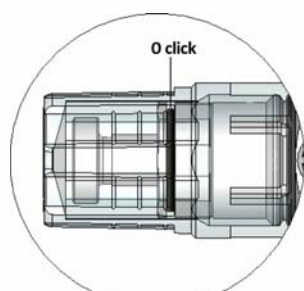
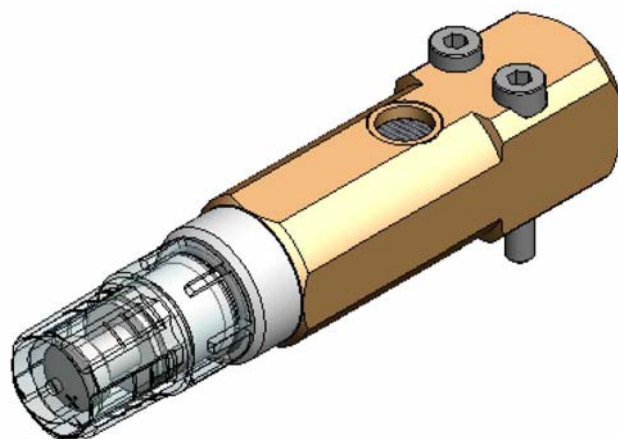

SCATTI <i>INCREMENTS</i>	PORTATA / CICLO <i>DISCHARGE / CYCLE</i>
CLICK 0	39,00
CLICK 1	37,23
CLICK 2	35,47
CLICK 3	33,70
CLICK 4	31,93
CLICK 5	30,16
CLICK 6	28,40
CLICK 7	26,63
CLICK 8	24,86
CLICK 9	23,10
CLICK 10	21,33
CLICK 11	19,56
CLICK 12	17,79
CLICK 13	16,03
CLICK 14	14,26
CLICK 15	12,49
CLICK 16	10,73
CLICK 17	8,96
CLICK 18	7,19
CLICK 19	5,42
CLICK 20	3,66
CLICK 21	1,89
CLICK 22	0,12
CLICK 23	0,00
CLICK 24	0,00
CLICK 25	0,00
CLICK 26	0,00
CLICK 27	0,00



**IMPOSTAZIONE DEI CICLI DEL GENERATORE DI FREQUENZA
CON ARIA A 6 BAR (90 PSI)**

**HOW TO ADJUST THE FREQUENCY GENERATOR WITH AIR AT 6
BAR (90 PSI)**

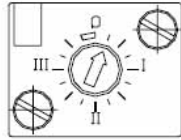

66 CICLI / MINUTO
66 STROKES / MINUTE

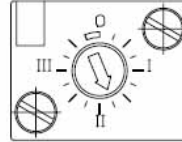

5 CICLI / MINUTO
5 STROKES / MINUTE

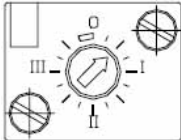

37 CICLI / MINUTO
37 STROKES / MINUTE

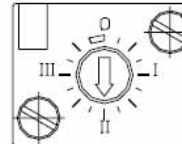

4 CICLI / MINUTO
4 STROKES / MINUTE

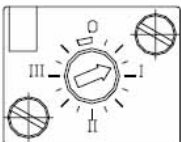

21 CICLI / MINUTO
21 STROKES / MINUTE

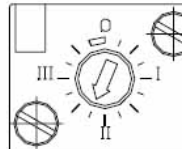

3 CICLI / MINUTO
3 STROKES / MINUTE

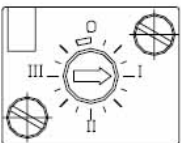

13 CICLI / MINUTO
13 STROKES / MINUTE

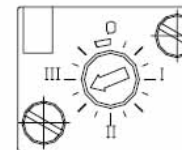

2 CICLI / MINUTO
2 STROKES / MINUTE

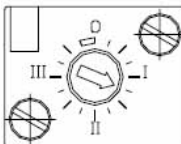

10 CICLI / MINUTO
10 STROKES / MINUTE

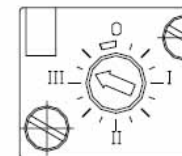

1 CICLO / MINUTO
1 STROKE / MINUTE

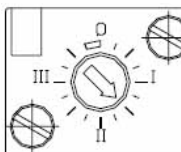

6 CICLI / MINUTO
6 STROKES / MINUTE

CON UNA PRESSIONE A 5 BAR (75 PSI) I VALORI DEVONO ESSERE INCREMENTATI DEL 7%

WITH THE AIR PRESSURE 5 BAR (75 PSI) THE VALUES HAVE TO BE INCREASED OF ABOUT 7%

CON UNA PRESSIONE A 7 BAR (105 PSI) I VALORI DEVONO ESSERE RIDOTTI DEL 4%

WITH THE AIR PRESSURE 7 BAR (105 PSI) THE VALUES HAVE TO BE DECREASED OF ABOUT 4%

CON UNA PRESSIONE A 8 BAR (120 PSI) I VALORI DEVONO ESSERE RIDOTTI DELL' 8%

WITH THE AIR PRESSURE 8 BAR (120 PSI) THE VALUES HAVE TO BE DECREASED OF ABOUT 8%



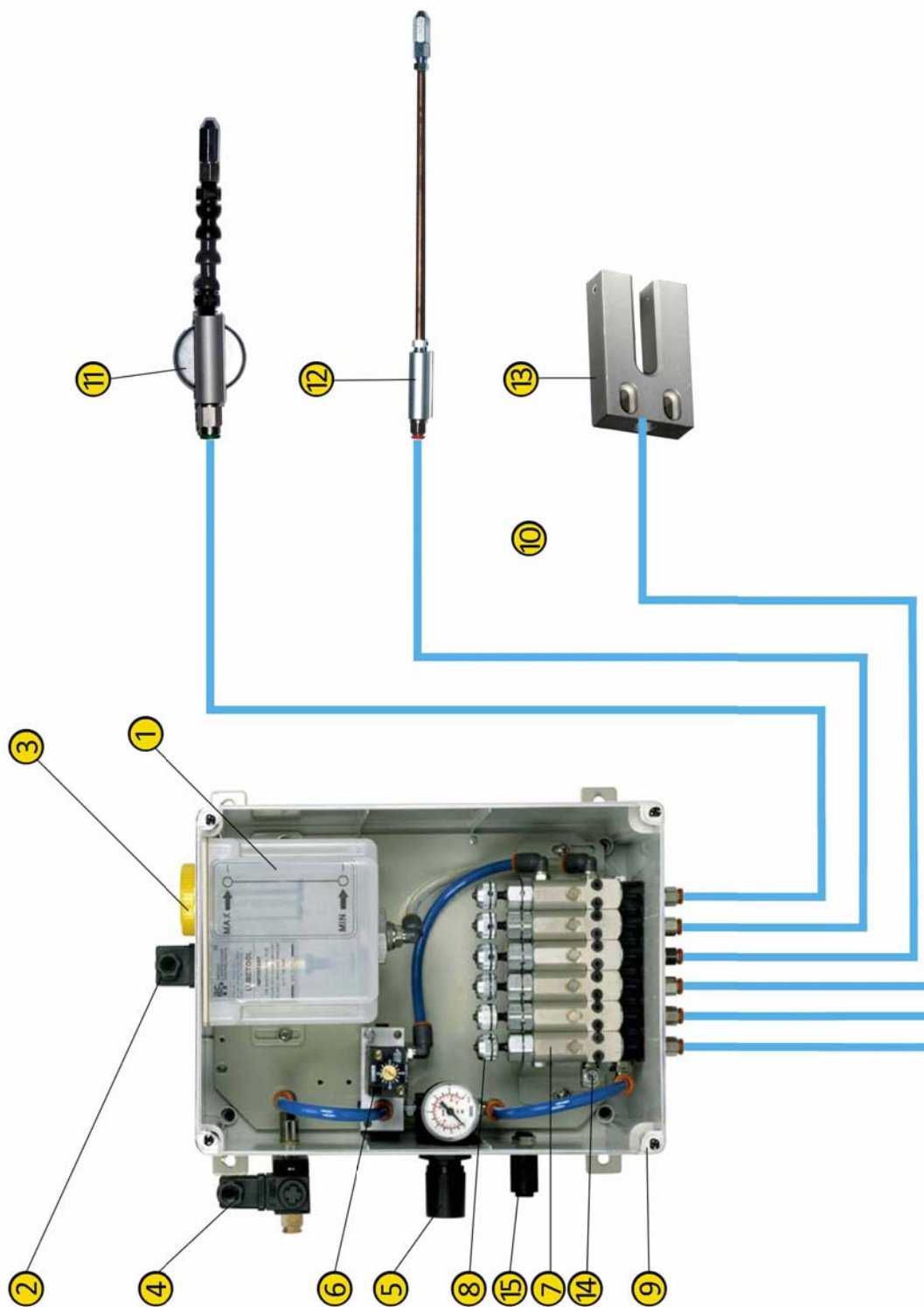

CARATTERISTICHE E DESCRIZIONE COMPONENTI

INFORMATION AND OPERATING INSTRUCTIONS

1.SERBATOIO: CAPACITA' 1.2 L , 2.2 L O 3,6 L IN NYLON SEMITRASPARENTE E RESISTENTE AGLI URTI

1.LIQUID RESERVOIR: SEMITRASPARENT, NYLON IMPACT RESISTANT HAS A CAPACITY OF 1.2 L, 2.2 L OR 3.6 L

2.MINIMO LIVELLO ELETTRICO: IL CONTATTO CHIUDE QUANDO IL SERBATOIO SI SVUOTA

2.LOW LEVEL SWITCH: THE CONTACT CLOSE WHEN THE RESERVOIR IS EMPTY.

3.TAPPO RIEMPIMENTO: PER RIEMPIRE DI OLIO IL SERBATOIO

3.FILLER CUP: TO RE-FILL OIL IN THE RESERVOIR.

4.ALIMENTAZIONE D'ARIA: L'ARIA NEL SISTEMA VIENE INVIATA MEDIANTE UNA ELETTROVALVOLA CON BOBINA DA 24 V DC, 24 V AC, 115 V AC O 230 V AC. L'ARIA DOVRA' AVERE UNA PRESSIONE NON INFERIORE AI 5 BAR (75 PSI) E NON SUPERIORE A 8 BAR (120 PSI). PER EVITARE CHE PARTICELLE O ACQUA ENTRINO NEL SISTEMA E' NECESSARIO UTILIZZARE UN FILTRO DEUMIDIFICATORE DA 5 MICRON

4.AIR SUPPLY: A SOLENOID VALVE WITH A COIL 24 V DC, 24 V AC, 115 V AC OR 230 V AC SUPPLY THE AIR IN THE SYSTEM. AIR PRESSURE SHOULD BE MIN 5 BAR (75 PSI) MAX 8 BAR (120 PSI). VERY IMPORTANT IS TO INSTALL A STANDARD PARTICLE FILTER (5 MICRON) TO ELIMINATE PARTICLES AND WATER FROM ENTERING THE SYSTEM. IF THERE IS PROBLEM WITH OIL IN THE AIR SYSTEM, WE SUGGEST RUNNING A COALESCING FILTER IN TANDEM WITH THE PARTICLE AIR FILTER.

5.RIDUTTORE CON MANOMETRO: REGOLA IL FLUSSO DELL'ARIA DA INVIARE AGLI UGELLI. RUOTANDOLO IN SENSO ORARIO AUMENTA L'ARIA E LA DIMINUISCE RUOTANDOLO IN SENSO ANTIORARIO. L'ARIA DOVRA' AVERE UNA PRESSIONE NON INFERIORE AI 0.5 BAR (8 PSI) E NON SUPERIORE AI 3 BAR (45 PSI). NOI SUGGERIAMO 1.5 BAR (22 PSI)

5.AIR REGULATOR WITH GAUGE: THIS SWITCH ALLOWS THE FLOW OF AIR TO GO IN THE NOZZLES. TURN SWITCH CLOCKWISE TO TURN AIR ON, AND COUNTER-CLOCKWISE TO TURN AIR OFF. THE AIR PRESSURE HAS TO BE FROM 0.5 BAR (8 PSI) TO 3 BAR (45 PSI). WE SUGGEST 1.5 BAR (22 PSI).

6.GENERATORE DI FREQUENZA: QUESTA VALVOLA CONTROLLA LA FREQUENZA DEI CICLI DELLA POMPA. PER AUMENTARE LA FREQUENZA DEI CICLI DELLA POMPA BISOGNA RUOTARE LA VITE DI REGOLAZIONE IN SENSO ANTIORARIO.

6.FREQUENCY GENERATOR: THIS VALVE CONTROLS THE FREQUENCY AT WITCH THE PUMP CYCLE. TO INCREASE THE SPEED OF THE PUMPS, TURN SCREWDRIVER ADJUSTMENT COUNTER-CLOCKWISE.

7.POMPA PNEUMATICA: OGNI CORSA FORNISCE UNA ESATTA QUANTITA' DI LUBRIFICANTE ALL'USCITA

7.PNEUMATIC PUMP: EACH STROKE GIVE AN EXACT AMOUNT OF OIL TO THE OUTLET.

8.REGOLAZIONE DELLA PORTATA: I POMOLI REGOLANO LA PORTATA DEL LUBRIFICANTE CHE VIENE FORNITA AD OGNI CORSA DELLA POMPA (REGOLABILE DA 0 MM³ A 41 MM³ /CORSA).

8.OIL FLOW ADJUSTMENT: THE MANUAL RATCHETS REGULATE THE AMOUNT OF LUBRICANT THAT IS SUPPLIED WITH EACH STROKE OF THE PUMP (ADJUSTABLE FROM 0 MM³ TO 41 MM³ /STROKE).

9.CONTENITORE: IN PLASTICA, RESISTENTE AGLI URTI

9.BOX: DURABLE IMPACT-RESISTANT LOCKING PLASTIC BOX.

10.TUBAZIONI DI MANDATA COASSIALI: PER INVIARE OLIO SEPARATO DALL'ARIA AGLI UGELLI

10.COAXIAL FEEDING LINE: TO SUPPLY OIL SEPARATE FROM AIR TO THE NOZZLE.

11.UGELLO COMPLETO DI LOC-LINE CON BASE MAGNETICA

11.LOC-LINE MAGNETIC BASE NOZZLE

12.UGELLO COMPLETO DI TUBAZIONE RIGIDA CON BASE FISSA

12.STEEL FIXED BASE NOZZLE

13. UGELLO A SELLA

13. SAW SADDLE NOZZLE

14.DRENAGGIO ARIA: PER SPURGARE L'ARIA DALL'OLIO

14.AIR DRAIN: TO PURGE AIR FROM THE OIL SYSTEM

15.FILTRO SCARICO ARIA

15.STRAINER EXHAUST AIR



UNITA' LUBETOOL UCGF, UCGF-SE, AGGF E AGGF-SE CON GENERATORE DI FREQUENZA

IL CIRCUITO PNEUMATICO INTERNO SI DIRAMA IN CORRISPONDENZA DEL GENERATORE DI FREQUENZA. DURANTE IL TEMPO DI ATTIVAZIONE DELL'ELETTROVALVOLA SI AVRA' UN FLUSSO COSTANTE DI ARIA AI TUBI DI PROIEZIONE, MENTRE IL GENERATORE DI FREQUENZA REGOLERA' LE CORSE DELLA MICROPOMPA. L'ELETTROVALVOLA DEVE ESSERE ATTIVATA PRIMA CHE L'UTENSILE INIZI A LAVORARE E DEVE ESSERE CHIUSA QUANDO L'UTENSILE FINISCE.

LUBETOOL UCGF, UCGF-SE, AGGF AND AGGF-SE WITH FREQUENCY GENERATOR

THE INSIDE PNEUMATIC CIRCUIT GOES DIRECT TO THE AIR FEEDING LINES AND TO THE PUMPS (THROUGH THE FREQUENCY GENERATOR). WHEN THE SOLENOID VALVE IS ENERGIZED THE PUMPS CAN CYCLE (ADJUSTABLE WITH THE FREQUENCY GENERATOR) AND AIR IS SENT CONTINUOUSLY TO THE TOOL. THE SOLENOID VALVE HAS TO BE ENERGIZED BEFORE THE TOOL WILL BEGIN TO MACHINE AND SHUT DOWN WHEN THE TOOL WILL FINISH TO MACHINE.

UNITA' LUBETOOL UCSG, UCSG-SE, AGSG E AGSG-SE SENZA GENERATORE DI FREQUENZA

QUESTE UNITA' SONO DESTINATE AD IMPIEGHI DOVE E' RICHIESTO UN CICLO DI INTERVENTO PROGRAMMATO DA UN COMANDO ESTERNO DELLA MACCHINA. AD OGNI ATTIVAZIONE DELL'ELETTROVALVOLA CORRISPONDERA' L'INVIO DEL FLUSSO DI ARIA NELLE TUBAZIONI DI MANDATA E SIMULTANEAMENTE UN EROGAZIONE DEL LUBRIFICANTE DALLE MICROPOMPE. QUESTA OPERAZIONE PUO' ESSERE RIPETUTA PIU' VOLTE INTERPONENDO UNA PAUSA PER LA RICARICA DEL LUBRIFICANTE DI ALMENO 0.5 SECONDI.

LUBETOOL UCSG, UCSG-SE, AGSG AND AGSG-SE WITHOUT FREQUENCY GENERATOR

THE UCSG TYPES NEED AN EXTERNAL DRIVE TO ADJUST THE FREQUENCY AT WHICH THE PUMPS CYCLE. THE INSIDE PNEUMATIC CIRCUIT GOES DIRECT TO THE AIR FEEDING LINES AND TO THE PUMPS. WHEN THE SOLENOID VALVE IS ENERGIZED THE PUMPS CAN CYCLE 1 TIME AND AIR IS SENT CONTINUOUSLY TO THE TOOLS. TO HAVE ANOTHER PUMP CYCLE THE SOLENOID VALVE HAVE TO BE DEENERGIZED AND AFTER ENERGIZED (MINIMUM PAUSE TIME IS 0.5 SECONDS).

CARATTERISTICHE

FEATURES

PORTATA	DA 0 MM ³ A 41 MM ³	DISCHARGE	FROM 0 MM ³ TO 41 MM ³
POMPE	DA 1 A 6	PUMPS	FROM 1 TO 6
ELETTROVALVOLA	24 V DC – 24 V AC – 115 V AC – 230 V AC	SOLENOID VALVE	24 V DC – 24 V AC – 115 V AC – 230 V AC
CORSE	DA 3 AL SECONDO A 1 AL MINUTO	STROKES	FROM 3 /SECOND TO 1 / MINUTE
SERBATOIO	1.2 L	RESERVOIR	1.2 L
LUBRIFICANTE	OLIO MAX 800 cSt 40 °C	LUBRICANT	OIL MAX 800 cSt 40 °C
LIVELLO ELETTRICO	1 A 250 V AC – 220 V DC – 50 W	LOW LEVEL SWITCH	1 A 250 V AC – 220 V DC – 50 W
PRESSIONE ARIA	DA 4 BAR A 8 BAR	AIR PRESSURE	FROM 4 BAR TO 8 BAR
CONSUMO ARIA PER PUNTO A 6 BAR	MIN: 60 L/M – MAX 100 L/M	AIR CONSUME AT 6 BAR/POINT	MIN: 60 L/M – MAX 100 L/M



UCGF

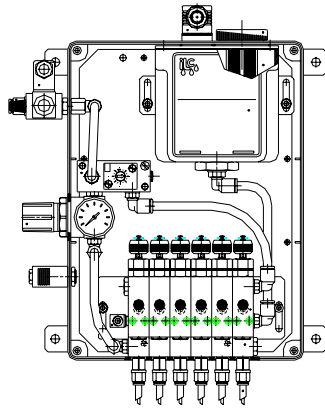

L'UNITA' E' FORNITA COMPLETA DI:

- SERBATOIO 1.2 L
- LIVELLO ELETTRICO: 1 A 250 V AC 200 V DC 50 W
- POMPE DA 1 A 6
- 5 M TUBO COASSIALE PER OGNI USCITA (6 MM – 2.5 MM)

SCATOLA DI PROTEZIONE ABS PORTA TRASPARENTE

ELETTROVALVOLA 24 V DC – 24 V AC – 115 V AC O 230 V AC
LA TENSIONE DEVE ESSERE AGGIUNTA AL CODICE. ESEMPIO
70.000.0.24VDC

REGOLATORE D'ARIA + MANOMETRO

GENERATORE DI FREQUENZA

THE UNIT IS SUPPLIED COMPLETE OF:

- RESERVOIR 1.2 L
- LOW LEVEL SWITCH: 1 A 250 V AC 200 V DC 50 W
- PUMPS FROM 1 TO 6
- 5 M COAXIAL FEEDING LINES FOR EACH OUTLET (6 MM – 2.5 MM)

BOX ABS WITH TRANSPARENT FRONT DOOR

SOLENOID VALVE 24 V DC – 24 V AC – 115 V AC OR 230 V AC
THE VOLTAGE HAS TO BE ADD TO THE CODE. EXAMPLE
70.000.0.24VDC

AIR REGULATOR + PRESSURE GAUGE

FREQUENCY GENERATOR

CODICI DI ORDINAZIONE – CODES FOR ORDER

CODICE CODE	MODELLO TYPE	NUMERO DI POMPE PUMPS NUMBER
70.000.0	UCGF – 1	1
70.000.1	UCGF – 2	2
70.000.2	UCGF – 3	3
70.000.3	UCGF – 4	4
70.000.4	UCGF – 5	5
70.000.5	UCGF – 6	6

CODICI PER ORDINARE BOBINE DELL'ELETTROVALVOLA – CODES TO ORDER SOLENOID VALVE COILS

14.660.1.R	14.660.2.R	14.660.3.R	14.660.4.R
24 V DC	115 V AC	230 V AC	24 V AC



UCGF-SE

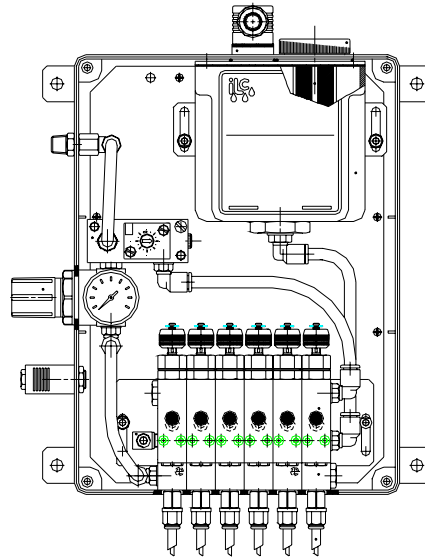

L'UNITA' E' FORNITA COMPLETA DI:

- SERBATOIO 1.2 L
- LIVELLO ELETTRICO: 1 A 250 V AC 200 V DC 50 W
- POMPE DA 1 A 6
- 5 M TUBO COASSIALE PER OGNI USCITA (6 MM – 2.5 MM)
- SCATOLA DI PROTEZIONE ABS PORTA TRASPARENTE
- REGOLATORE D'ARIA + MANOMETRO
- GENERATORE DI FREQUENZA

THE UNIT IS SUPPLIED COMPLETE OF:

- RESERVOIR 1.2 L
- LOW LEVEL SWITCH: 1 A 250 V AC 200 V DC 50 W
- PUMPS FROM 1 TO 6
- 5 M COAXIAL FEEDING LINES FOR EACH OUTLET (6 MM – 2.5 MM)
- BOX ABS WITH TRANSPARENT FRONT DOOR
- AIR REGULATOR + PRESSURE GAUGE
- FREQUENCY GENERATOR

CODICI DI ORDINAZIONE – CODES FOR ORDER

CODICE CODE	MODELLO TYPE	NUMERO DI POMPE PUMPS NUMBER
70.009.0	UCGF – SE - 1	1
70.009.1	UCGF – SE - 2	2
70.009.2	UCGF – SE - 3	3
70.009.3	UCGF – SE - 4	4
70.009.4	UCGF – SE - 5	5
70.009.5	UCGF – SE - 6	6



DIMENSIONI D'INGOMBRO UCGF

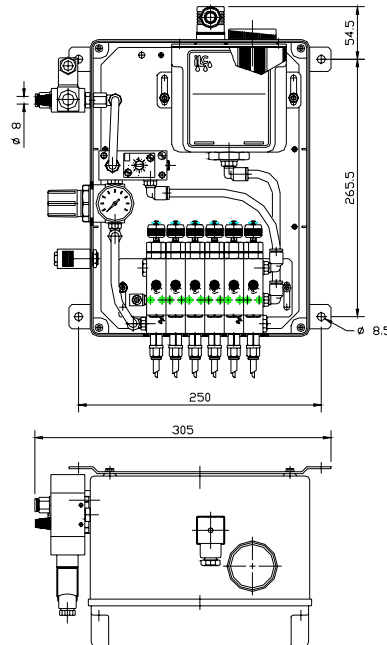

OVERALL DIMENSION UCGF

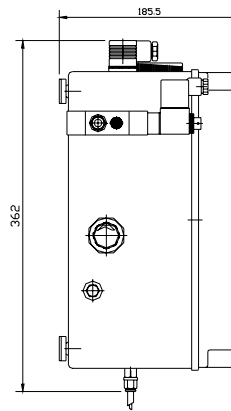

DIMENSIONI D'INGOMBRO UCGF - SE

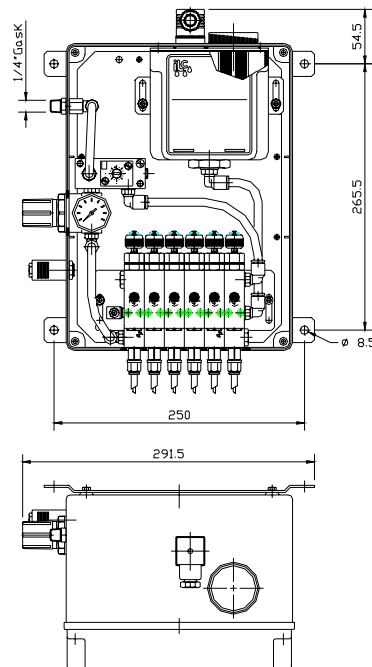

OVERALL DIMENSION UCGF - SE

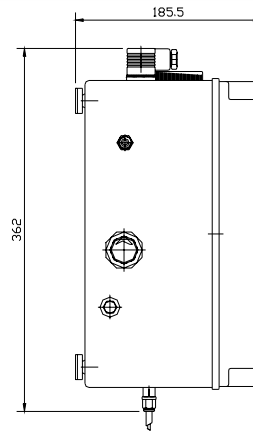

UCSG

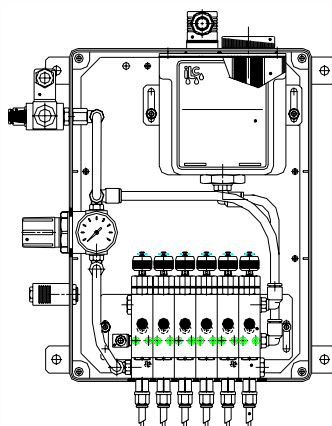

L'UNITA' E' FORNITA COMPLETA DI:

- SERBATOIO 1.2 L
- LIVELLO ELETTRICO: 1 A 250 V AC 200 V DC 50 W
- POMPE DA 1 A 6
- 5 M TUBO COASSIALE PER OGNI USCITA (6 MM – 2.5 MM)
- SCATOLA DI PROTEZIONE ABS PORTA TRASPARENTE
- ELETTRIVALVOLA 24 V DC – 24 V AC – 115 V AC O 230 V AC
LA TENSIONE DEVE ESSERE AGGIUNTA AL CODICE. ESEMPIO
70.001.0.24VDC
- REGOLATORE D'ARIA + MANOMETRO

THE UNIT IS SUPPLIED COMPLETE OF:

- RESERVOIR 1.2 L
- LOW LEVEL SWITCH: 1 A 250 V AC 200 V DC 50 W
- PUMPS FROM 1 TO 6
- 5 M COAXIAL FEEDING LINES FOR EACH OUTLET (6 MM – 2.5 MM)
- BOX ABS WITH TRANSPARENT FRONT DOOR
- SOLENOID VALVE 24 V DC – 24 V AC – 115 V AC OR 230 V AC
THE VOLTAGE HAS TO BE ADD TO THE CODE. EXAMPLE
70.001.0.24VDC
- AIR REGULATOR + PRESSURE GAUGE

CODICI DI ORDINAZIONE – CODES FOR ORDER

CODICE CODE	MODELLO TYPE	NUMERO DI POMPE PUMPS NUMBER
70.001.0	UCSG - 1	1
70.001.1	UCSG – 2	2
70.001.2	UCSG – 3	3
70.001.3	UCSG – 4	4
70.001.4	UCSG – 5	5
70.001.5	UCSG - 6	6

CODICI PER ORDINARE BOBINE DELL'ELETTRIVALVOLA – CODES TO ORDER SOLENOID VALVE COILS

14.660.1.R	14.660.2.R	14.660.3.R	14.660.4.R
24 V DC	115 V AC	230 V AC	24 V AC



UCSG-SE

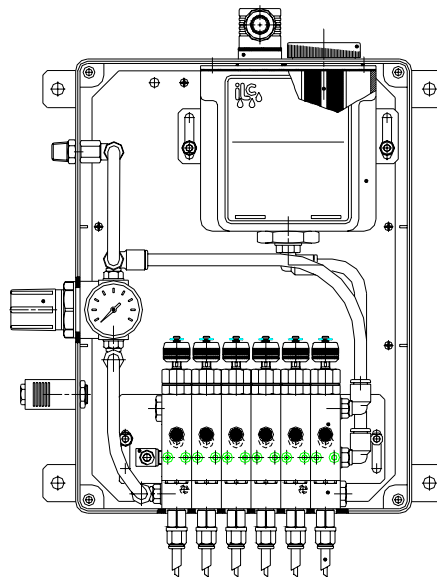

L'UNITA' E' FORNITA COMPLETA DI:

- SERBATOIO 1.2 L
- LIVELLO ELETTRICO: 1 A 250 V AC 200 V DC 50 W
- POMPE DA 1 A 6
- 5 M TUBO COASSIALE PER OGNI USCITA (6 MM – 2.5 MM)
- SCATOLA DI PROTEZIONE ABS PORTA TRASPARENTE
- REGOLATORE D'ARIA + MANOMETRO

THE UNIT IS SUPPLIED COMPLETE OF:

- RESERVOIR 1.2 L
- LOW LEVEL SWITCH: 1 A 250 V AC 200 V DC 50 W
- PUMPS FROM 1 TO 6
- 5 M COAXIAL FEEDING LINES FOR EACH OUTLET (6 MM – 2.5 MM)
- BOX ABS WITH TRANSPARENT FRONT DOOR
- AIR REGULATOR + PRESSURE GAUGE

CODICI DI ORDINAZIONE – CODES FOR ORDER

CODICE CODE	MODELLO TYPE	NUMERO DI POMPE PUMPS NUMBER
70.010.0	UCSG – SE - 1	1
70.010.1	UCSG – SE - 2	2
70.010.2	UCSG – SE - 3	3
70.010.3	UCSG – SE - 4	4
70.010.4	UCSG – SE - 5	5
70.010.5	UCSG – SE - 6	6



DIMENSIONI D'INGOMBRO UCSG

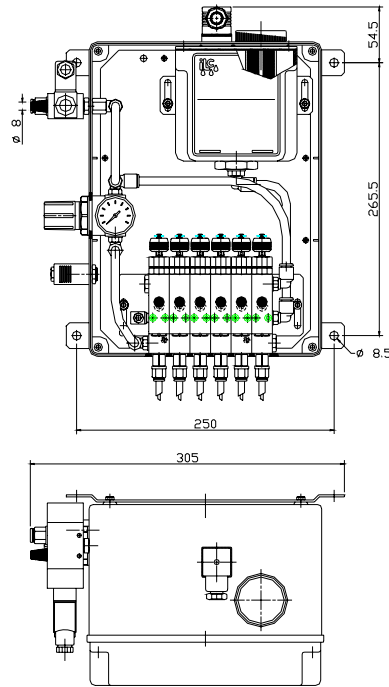

OVERALL DIMENSION UCSG

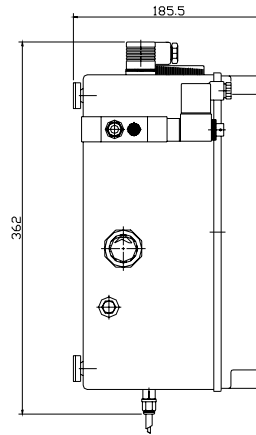

DIMENSIONI D'INGOMBRO UCSG - SE

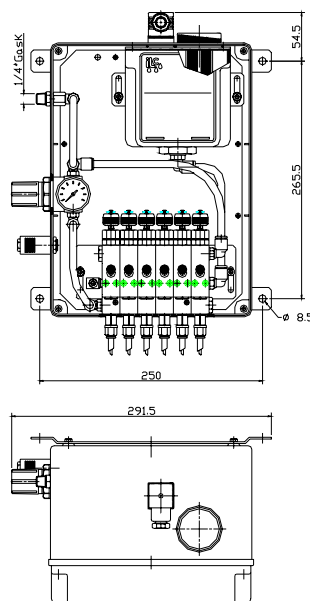

OVERALL DIMENSION UCSG - SE

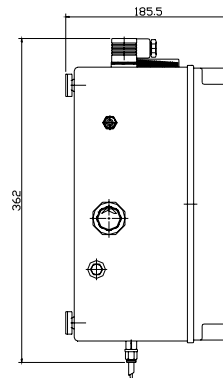

AGGF

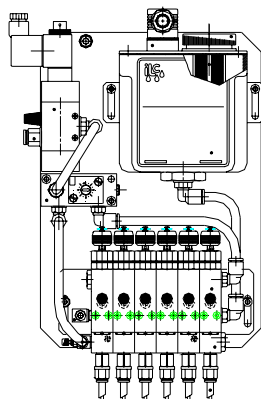

L'UNITA' E' FORNITA COMPLETA DI:

- SERBATOIO 1.2 L
- LIVELLO ELETTRICO: 1 A 250 V AC 200 V DC 50 W
- POMPE DA 1 A 6
- 5 M TUBO COASSIALE PER OGNI USCITA (6 MM – 2.5 MM)

ELETTROVALVOLA 24 V DC – 24 V AC – 115 V AC O 230 V AC
LA TENSIONE DEVE ESSERE AGGIUNTA AL CODICE. ESEMPIO
70.006.0.24VDC

REGOLATORE D'ARIA

GENERATORE DI FREQUENZA

THE UNIT IS SUPPLIED COMPLETE OF:

- RESERVOIR 1.2 L
- LOW LEVEL SWITCH: 1 A 250 V AC 200 V DC 50 W
- PUMPS FROM 1 TO 6
- 5 M COAXIAL FEEDING LINES FOR EACH OUTLET (6 MM – 2.5 MM)

SOLENOID VALVE 24 V DC – 24 V AC – 115 V AC OR 230 V AC
THE VOLTAGE HAS TO BE ADD TO THE CODE. EXAMPLE
70.006.0.24VDC

AIR REGULATOR

FREQUENCY GENERATOR

CODICI DI ORDINAZIONE – CODES FOR ORDER

CODICE CODE	MODELLO TYPE	NUMERO DI POMPE PUMPS NUMBER
70.006.0	AGGF - 1	1
70.006.1	AGGF - 2	2
70.006.2	AGGF - 3	3
70.006.3	AGGF - 4	4
70.006.4	AGGF - 5	5
70.006.5	AGGF - 6	6

CODICI PER ORDINARE BOBINE DELL'ELETTRVALVOLA – CODES TO ORDER SOLENOID VALVE COILS

14.660.1.R	14.660.2.R	14.660.3.R	14.660.4.R
24 V DC	115 V AC	230 V AC	24 V AC



AGGF - SE

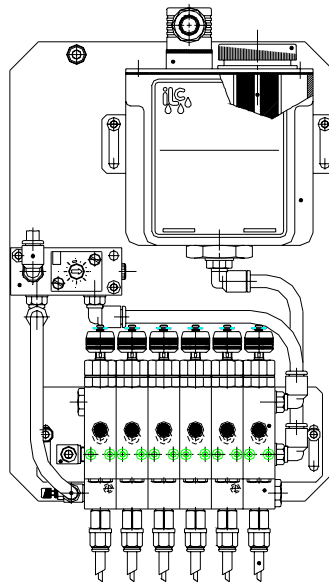

L'UNITA' E' FORNITA COMPLETA DI:

- SERBATOIO 1.2 L
- LIVELLO ELETTRICO: 1 A 250 V AC 200 V DC 50 W
- POMPE DA 1 A 6
- 5 M TUBO COASSIALE PER OGNI USCITA (6 MM – 2.5 MM)
- REGOLATORE D'ARIA
- GENERATORE FI FREQUENZA

THE UNIT IS SUPPLIED COMPLETE OF:

- RESERVOIR 1.2 L
- LOW LEVEL SWITCH: 1 A 250 V AC 200 V DC 50 W
- PUMPS FROM 1 TO 6
- 5 M COAXIAL FEEDING LINES FOR EACH OUTLET (6 MM – 2.5 MM)
- AIR REGULATOR
- FREQUENCY GENERATOR

CODICI DI ORDINAZIONE – CODES FOR ORDER

CODICE CODE	MODELLO TYPE	NUMERO DI POMPE PUMPS NUMBER
70.002.0	AGGF – SE - 1	1
70.002.1	AGGF – SE - 2	2
70.002.2	AGGF – SE - 3	3
70.002.3	AGGF – SE - 4	4
70.002.4	AGGF – SE - 5	5
70.002.5	AGGF – SE - 6	6



DIMENSIONI D'INGOMBRO AGGF

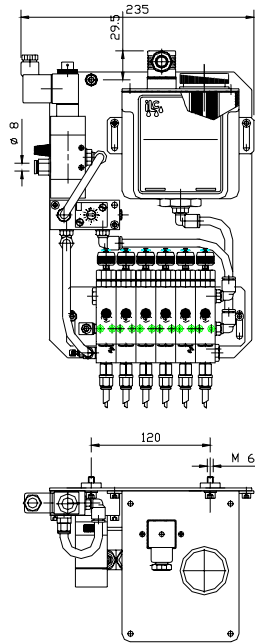

OVERALL DIMENSION AGGF

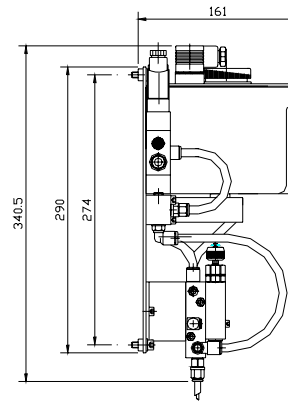

DIMENSIONI D'INGOMBRO AGGF - SE

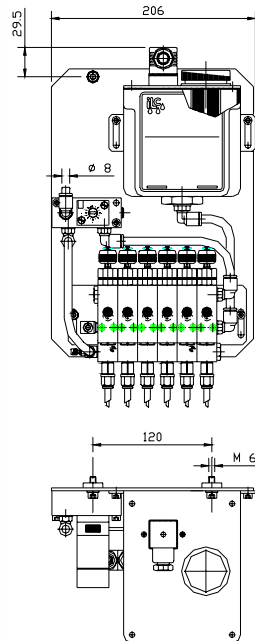

OVERALL DIMENSION AGGF - SE

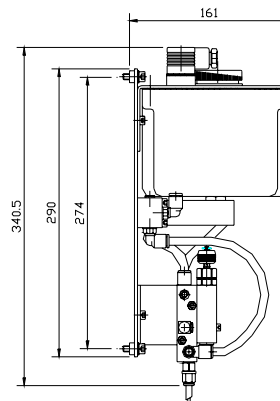

AGSG

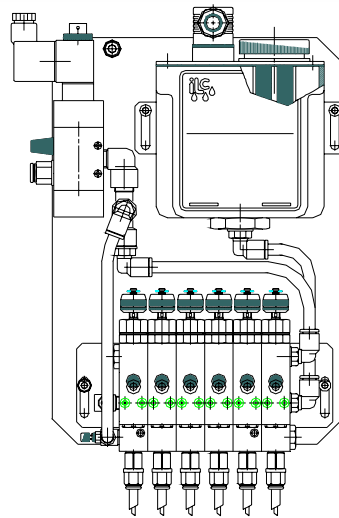

L'UNITA' E' FORNITA COMPLETA DI:

- SERBATOIO 1.2 L
- LIVELLO ELETTRICO: 1 A 250 V AC 200 V DC 50 W
- POMPE DA 1 A 6
- 5 M TUBO COASSIALE PER OGNI USCITA (6 MM – 2.5 MM)

ELETTROVALVOLA 24 V DC – 24 V AC – 115 V AC O 230 V AC
LA TENSIONE DEVE ESSERE AGGIUNTA AL CODICE. ESEMPIO
70.018.0.24VDC

REGOLATORE D'ARIA

THE UNIT IS SUPPLIED COMPLETE OF:

- RESERVOIR 1.2 L
- LOW LEVEL SWITCH: 1 A 250 V AC 200 V DC 50 W
- PUMPS FROM 1 TO 6
- 5 M COAXIAL FEEDING LINES FOR EACH OUTLET (6 MM – 2.5 MM)

SOLENOID VALVE 24 V DC – 24 V AC – 115 V AC OR 230 V AC
THE VOLTAGE HAS TO BE ADD TO THE CODE. EXAMPLE
70.018.0.24VDC

AIR REGULATOR

CODICI DI ORDINAZIONE – CODES FOR ORDER

CODICE CODE	MODELLO TYPE	NUMERO DI POMPE PUMPS NUMBER
70.018.0	AGSG – 1	1
70.018.1	AGSG – 2	2
70.018.2	AGSG – 3	3
70.018.3	AGSG – 4	4
70.018.4	AGSG – 5	5
70.018.5	AGSG – 6	6

CODICI PER ORDINARE BOBINE DELL'ELETTROVALVOLA – CODES TO ORDER SOLENOID VALVE COILS

14.660.1.R	14.660.2.R	14.660.3.R	14.660.4.R
24 V DC	115 V AC	230 V AC	24 V AC



AGSG - SE

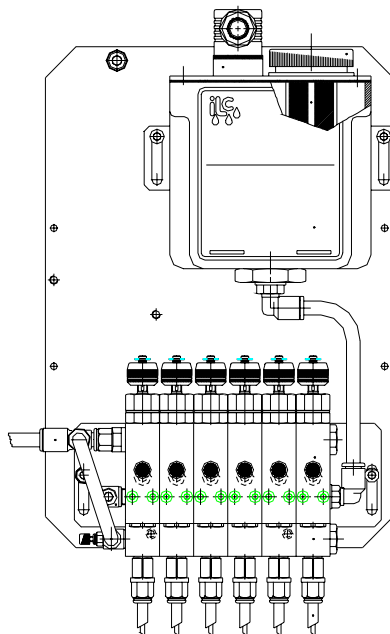

L'UNITA' E' FORNITA COMPLETA DI:

- SERBATOIO 1.2 L
- LIVELLO ELETTRICO: 1 A 250 V AC 200 V DC 50 W
- POMPE DA 1 A 6
- 5 M TUBO COASSIALE PER OGNI USCITA (6 MM – 2.5 MM)
- REGOLATORE D'ARIA

THE UNIT IS SUPPLIED COMPLETE OF:

- RESERVOIR 1.2 L
- LOW LEVEL SWITCH: 1 A 250 V AC 200 V DC 50 W
- PUMPS FROM 1 TO 6
- 5 M COAXIAL FEEDING LINES FOR EACH OUTLET (6 MM – 2.5 MM)
- AIR REGULATOR

CODICI DI ORDINAZIONE – CODES FOR ORDER

CODICE CODE	MODELLO TYPE	NUMERO DI POMPE PUMPS NUMBER
70.003.0	AGSG – SE - 1	1
70.003.1	AGSG – SE - 2	2
70.003.2	AGSG – SE - 3	3
70.003.3	AGSG – SE - 4	4
70.003.4	AGSG – SE - 5	5
70.003.5	AGSG – SE - 6	6



DIMENSIONI D'INGOMBRO AGSG

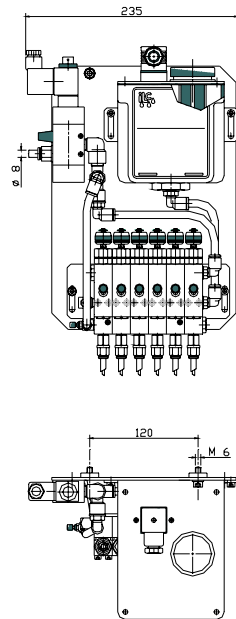

OVERALL DIMENSION AGSG

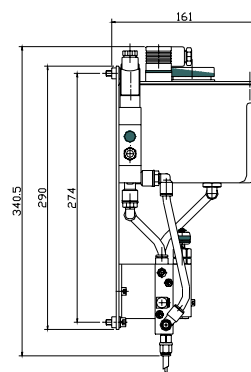

DIMENSIONI D'INGOMBRO AGSG - SE

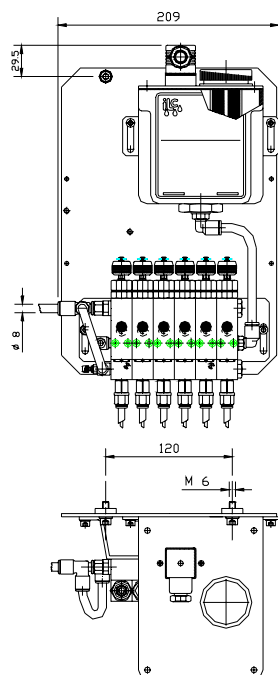

OVERALL DIMENSION AGSG - SE

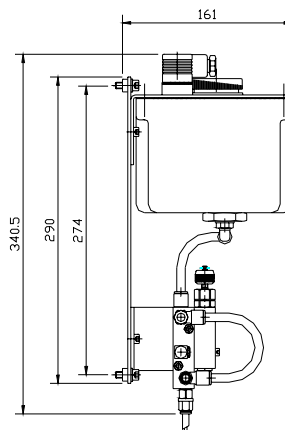

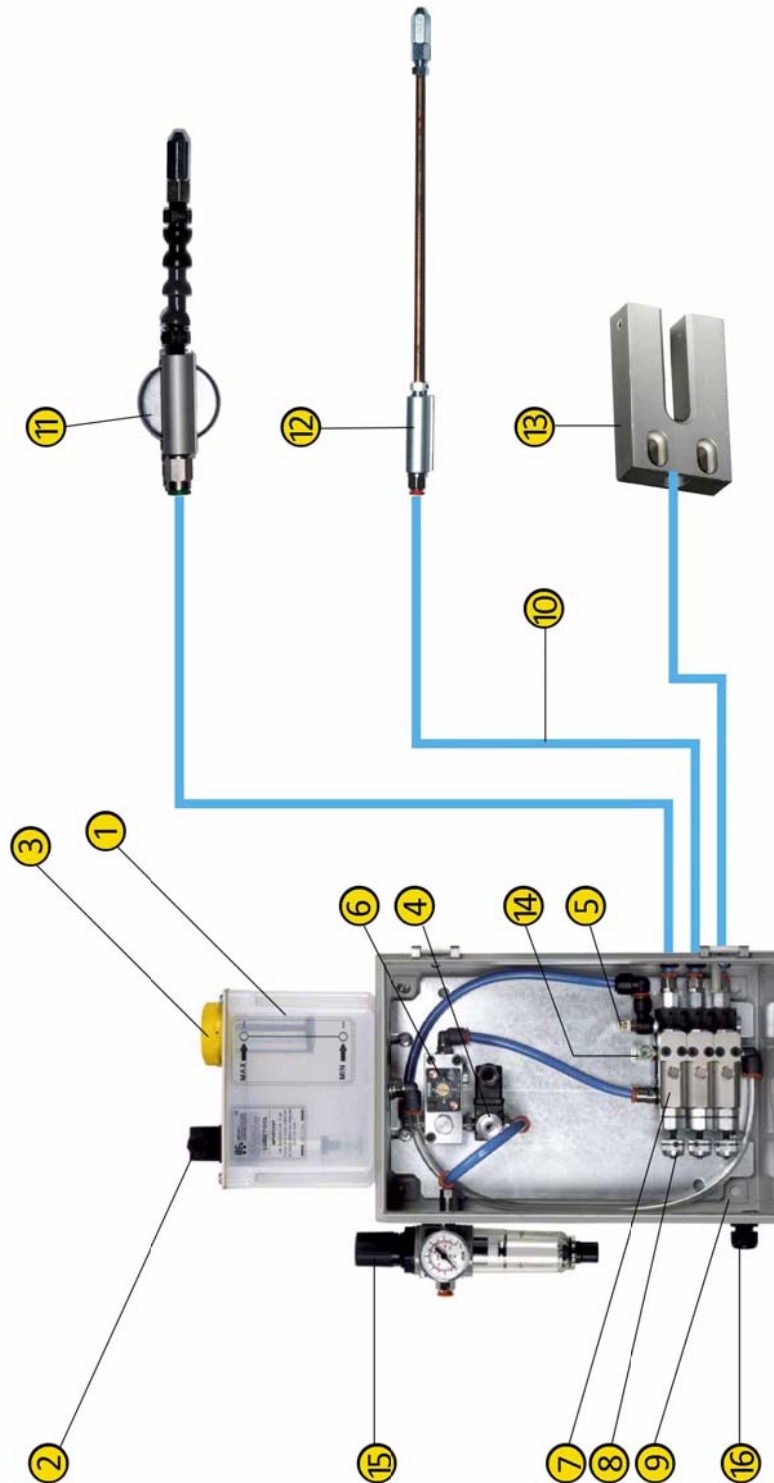

CARATTERISTICHE E DESCRIZIONE COMPONENTI

INFORMATION AND OPERATING INSTRUCTIONS

1.SERBATOIO: CAPACITA' 1.2 L , 2.2 L O 3,6 L IN NYLON SEMITRASPARENTE E RESISTENTE AGLI URTI

1.LIQUID RESERVOIR: SEMITRSPARENT, NYLON IMPACT RESISTANT HAS A CAPACITY OF 1.2 L, 2.2 L OR 3.6 L

2.MINIMO LIVELLO ELETTRICO: IL CONTATTO CHIUDE QUANDO IL SERBATOIO SI SVUOTA

2.LOW LEVEL SWITCH: THE CONTACT CLOSE WHEN THE RESERVOIR IS EMPTY.

3.TAPPO RIEMPIMENTO: PER RIEMPIRE DI OLIO IL SERBATOIO

3.FILLER CUP: TO RE-FILL OIL IN THE RESERVOIR.

4.ALIMENTAZIONE D'ARIA: L'ARIA NEL SISTEMA VIENE INVIATA MEDIANTE UNA ELETTROVALVOLA CON BOBINA DA 24 V DC, 24 V AC, 115 V AC O 230 V AC. L'ARIA DOVRA' AVERE UNA PRESSIONE NON INFERIORE AI 5 BAR (75 PSI) E NON SUPERIORE A 8 BAR (120 PSI). PER EVITARE CHE PARTICELLE O ACQUA ENTRINO NEL SISTEMA E' NECESSARIO UTILIZZARE UN FILTRO DEUMIDIFICATORE DA 5 MICRON

4.AIR SUPPLY: A SOLENOID VALVE WITH A COIL 24 V DC, 24 V AC, 115 V AC OR 230 V AC SUPPLY THE AIR IN THE SYSTEM. AIR PRESSURE SHOULD BE MIN 5 BAR (75 PSI) TO MAX 8 BAR (120 PSI). IT IS VERY IMPORTANT TO INSTALL A STANDARD PARTICLE FILTER (5 MICRON) TO ELIMINATE PARTICLES AND WATER FROM ENTERING THE SYSTEM. IF THERE IS PROBLEM WITH OIL IN THE AIR SYSTEM, WE SUGGEST RUNNING A COALESCING FILTER IN TANDEM WITH THE PARTICLE AIR FILTER.

5.REGOLATORE ARIA: REGOLA IL FLUSSO DELL'ARIA DA INVIARE AGLI UGELLI. RUOTANDOLO IN SENSO ORARIO AUMENTA L'ARIA E LA DIMINUISCE RUOTANDOLO IN SENSO ANTIORARIO. L'ARIA DOVRA' AVERE UNA PRESSIONE NON INFERIORE AI 0.5 BAR (8 PSI) E NON SUPERIORE AI 3 BAR (45 PSI). NOI SUGGERIAMO 1.5 BAR (22 PSI)

5.AIR REGULATOR: THIS SWITCH ALLOWS THE FLOW OF AIR TO GO IN THE NOZZLES. TURN SWITCH CLOCKWISE TO TURN AIR ON, AND COUNTER-CLOCKWISE TO TURN AIR OFF. THE AIR PRESSURE HAS TO BE FROM 0.5 BAR (8 PSI) TO 3 BAR (45 PSI). WE SUGGEST 1.5 BAR (22 PSI).

6.GENERATORE DI FREQUENZA: QUESTA VALVOLA CONTROLLA LA FREQUENZA DEI CICLI DELLA POMPA. PER AUMENTARE LA FREQUENZA DEI CICLI DELLA POMPA BISOGNA RUOTARE LA VITE DI REGOLAZIONE IN SENSO ANTIORARIO.

6.FREQUENCY GENERATOR: THIS VALVE CONTROLS THE FREQUENCY AT WHICH THE PUMP CYCLE. TO INCREASE THE SPEED OF THE PUMPS, TURN SCREWDRIVER ADJUSTMENT COUNTER-CLOCKWISE.

7.POMPA PNEUMATICA: OGNI CORSA FORNISCE UNA ESATTA QUANTITA' DI LUBRIFICANTE ALL'USCITA

7.PNEUMATIC PUMP: EACH STROKE GIVE AN EXACT AMOUNT OF OIL TO THE OUTLET.

8.REGOLAZIONE DELLA PORTATA: I POMOLI REGOLANO LA PORTATA DEL LUBRIFICANTE CHE VIENE FORNITA AD OGNI CORSA DELLA POMPA (REGOLABILE DA 0 MM³ A 41 MM³ /CORSA).

8.OIL FLOW ADJUSTMENT: THE MANUAL RATCHETS REGULATE THE AMOUNT OF LUBRICANT THAT IS SUPPLIED WITH EACH STROKE OF THE PUMP (ADJUSTABLE FROM 0 MM³ TO 41 MM³ /STROKE).

9.CONTENITORE: CONTENITORE IN METALLO

9.BOX: DURABLE IMPACT-RESISTANT LOCKING METALLIC BOX.

10.TUBAZIONI DI MANDATA COASSIALI: PER INVIARE OLIO SEPARATO DALL'ARIA AGLI UGELLI

10.COAXIAL FEEDING LINE: TO SUPPLY OIL SEPARATE FROM AIR TO THE NOZZLE.

11.UGELLO COMPLETO DI LOC-LINE CON BASE MAGNETICA

11.LOC-LINE MAGNETIC BASE NOZZLE

12.UGELLO COMPLETO DI TUBAZIONE RIGIDA CON BASE FISSA

12.STEEL FIXED BASE NOZZLE

13. UGELLO A SELLA

13. SAW SADDLE NOZZLE

14.DRENAGGIO ARIA: PER SPURGARE L'ARIA DALL'OLIO

14.AIR DRAIN: TO PURGE AIR FROM THE OIL SYSTEM

15.RIDUTTORE CON MANOMETRO

15.PRESSURE REDUCER WITH GAUGE

16.PRESSACAVO

16.CABLE GLAND



UNITA' LUBETOOL MC-EL-3P-4P-5P-6P-7P, MC-EL-3M-4M-5M-6M-7M, MC-EL-2P E MC-EL-2M
SONO FORNITI COMPLETI DI SCATOLA DI PROTEZIONE METALLICA

LUBETOOL MC-EL-3P-4P-5P-6P-7P, MC-EL-3M-4M-5M-6M-7M, MC-EL-2P E MC-EL-2M
THEY ARE SUPPLIED COMPLETE OF METALLIC BOX

CARATTERISTICHE		FEATURES	
PORTATA	DA 0 MM ³ A 41 MM ³	DISCHARGE	FROM 0 MM ³ TO 41 MM ³
POMPE	DA 1 A 7	PUMPS	FROM 1 TO 7
ELETTRIVALVOLA	24 V DC – 24 V AC – 115 V AC – 230 V AC	SOLENOID VALVE	24 V DC – 24 V AC – 115 V AC – 230 V AC
CORSE	DA 3 AL SECONDO A 1 AL MINUTO	STROKES	FROM 3 /SECOND TO 1 / MINUTE
SERBATOIO	1.2 L, 2.2 L O 3.6 L	RESERVOIR	1.2 L, 2.2 L OR 3.6 L
LUBRIFICANTE	OLIO MAX 800 cSt 40 °C	LUBRICANT	OIL MAX 800 cSt 40 °C
LIVELLO ELETTRICO	1 A 250 V AC – 220 V DC – 50 W	LOW LEVEL SWITCH	1 A 250 V AC – 220 V DC – 50 W
PRESSIONE ARIA	DA 4 BAR A 8 BAR	AIR PRESSURE	FROM 4 BAR TO 8 BAR
CONSUMO ARIA PER PUNTO A 6 BAR	MIN: 60 L/M – MAX 100 L/M	AIR CONSUME AT 6 BAR/POINT	MIN: 60 L/M – MAX 100 L/M



MC-EL-3P-4P-5P-6P-7P

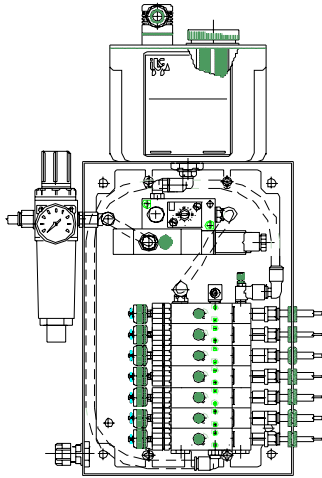

L'UNITA' E' FORNITA COMPLETA DI:	THE UNIT IS SUPPLIED COMPLETE OF:
SERBATOIO 1.2 L O 2.2 L	RESERVOIR 1.2 L OR 2.2 L
LIVELLO ELETTRICO: 1 A 250 V AC 200 V DC 50 W	LOW LEVEL SWITCH: 1 A 250 V AC 200 V DC 50 W
3-4-5-6-7 POMPE	3 -4-5-6-7 PUMPS
5 M TUBO COASSIALE PER OGNI USCITA (6 MM – 2.5 MM)	5 M COAXIAL LINES FOR EACH OUTLET (6 MM – 2.5 MM)
SCATOLA DI PROTEZIONE METALLICA	METALLIC BOX
ELETTROVALVOLA	SOLENOID VALVE
REGOLATORE D'ARIA	AIR REGULATOR
GENERATORE DI FREQUENZA	FREQUENCY GENERATOR
RIDUTTORE + MANOMETRO	AIR REDUCER + GAUGE

CODICI DI ORDINAZIONE – CODES FOR ORDER

CODICE CODE	MODELLO TYPE	CODICE CODE	MODELLO TYPE
70.050.7	MC-EL-3P-1.2	70.050.7.SL	MC-EL-3P-1.2-SL
70.050.8	MC-EL-3P-2.2	70.050.8.SL	MC-EL-3P-2.2-SL
70.051.3	MC-EL-4P-1.2	70.051.3.SL	MC-EL-4P-1.2-SL
70.051.4	MC-EL-4P-2.2	70.051.4.SL	MC-EL-4P-2.2-SL
70.051.5	MC-EL-5P-1.2	70.051.5.SL	MC-EL-5P-1.2-SL
70.051.6	MC-EL-5P-2.2	70.051.6.SL	MC-EL-5P-2.2-SL
70.051.7	MC-EL-6P-1.2	70.051.7.SL	MC-EL-6P-1.2-SL
70.051.8	MC-EL-6P-2.2	70.051.8.SL	MC-EL-6P-2.2-SL
70.054.0	MC-EL-7P-1.2	70.054.0.SL	MC-EL-7P-1.2-SL
70.054.1	MC-EL-7P-2.2	70.054.1.SL	MC-EL-7P-2.2-SL
SL: L'UNITA' E' FORNITA SENZA LIVELLO ELETTRICO		SL: THE UNIT WILL BE DELIVERED WITHOUT LOW LEVEL SWITCH	

CODICI PER ORDINARE BOBINE DELL'ELETTROVALVOLA – CODES TO ORDER SOLENOID VALVE COILS

14.660.1.R	14.660.2.R	16.660.3.R	14.660.4.R
24 V DC	115 V AC	230 V AC	24 V AC



MC-EL-3M-4M-5M-6M-7M

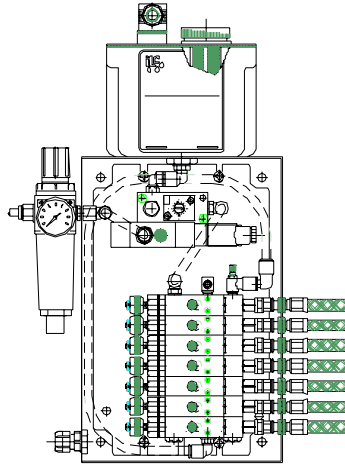

L'UNITA' E' FORNITA COMPLETA DI:

SERBATOIO 1.2 L O 2.2 L
LIVELLO ELETTRICO: 1 A 250 V AC 200 V DC 50 W
3-4-5-6-7 POMPE

IL TUBO COASSIALE METALLICO VA ORDINATO A PARTE CON
CODULO DA 8 MM. VEDI PAGINA 101

SCATOLA DI PROTEZIONE METALLICA
ELETTROVALVOLA
REGOLATORE D'ARIA
GENERATORE DI FREQUENZA
RIDUTTORE + MANOMETRO

THE UNIT IS SUPPLIED COMPLETE OF:

RESERVOIR 1.2 L OR 2.2 L
LOW LEVEL SWITCH: 1 A 250 V AC 200 V DC 50 W
3-4-5-6-7 PUMPS

COAXIAL FEEDING LINES (METALLIC COVERING) MUST BE
ORDERED SEPARATELY WITH 8 MM TERMINAL. SEE PAGE 101

METALLIC BOX
SOLENOID VALVE
AIR REGULATOR
FREQUENCY GENERATOR
AIR REDUCER + GAUGE

CODICI DI ORDINAZIONE – CODES FOR ORDER

CODICE CODE	MODELLO TYPE	CODICE CODE	MODELLO TYPE
70.053.1	MC-EL-3M-1.2	70.053.1.SL	MC-EL-3M-1.2-SL
70.053.2	MC-EL-3M-2.2	70.053.2.SL	MC-EL-3M-2.2-SL
70.053.4	MC-EL-4M-1.2	70.053.4.SL	MC-EL-4M-1.2-SL
70.053.5	MC-EL-4M-2.2	70.053.5.SL	MC-EL-4M-2.2-SL
70.053.6	MC-EL-5M-1.2	70.053.6.SL	MC-EL-5M-1.2-SL
70.053.7	MC-EL-5M-2.2	70.053.7.SL	MC-EL-5M-2.2-SL
70.053.8	MC-EL-6M-1.2	70.053.8.SL	MC-EL-6M-1.2-SL
70.053.9	MC-EL-6M-2.2	70.053.9.SL	MC-EL-6M-2.2-SL
70.054.4	MC-EL-7M-1.2	70.054.4.SL	MC-EL-7M-1.2-SL
70.054.5	MC-EL-7M-2.2	70.054.5.SL	MC-EL-7M-2.2-SL
SL: L'UNITA' E' FORNITA SENZA LIVELLO ELETTRICO		SL: THE UNIT WILL BE DELIVERED WITHOUT LOW LEVEL SWITCH	

CODICI PER ORDINARE BOBINE DELL'ELETTROVALVOLA – CODES TO ORDER SOLENOID VALVE COILS

14.660.1.R	14.660.2.R	14.660.3.R	14.660.4.R
24 V DC	115 V AC	230 V AC	24 V AC



DIMENSIONI D'INGOMBRO

OVERALL DIMENSION

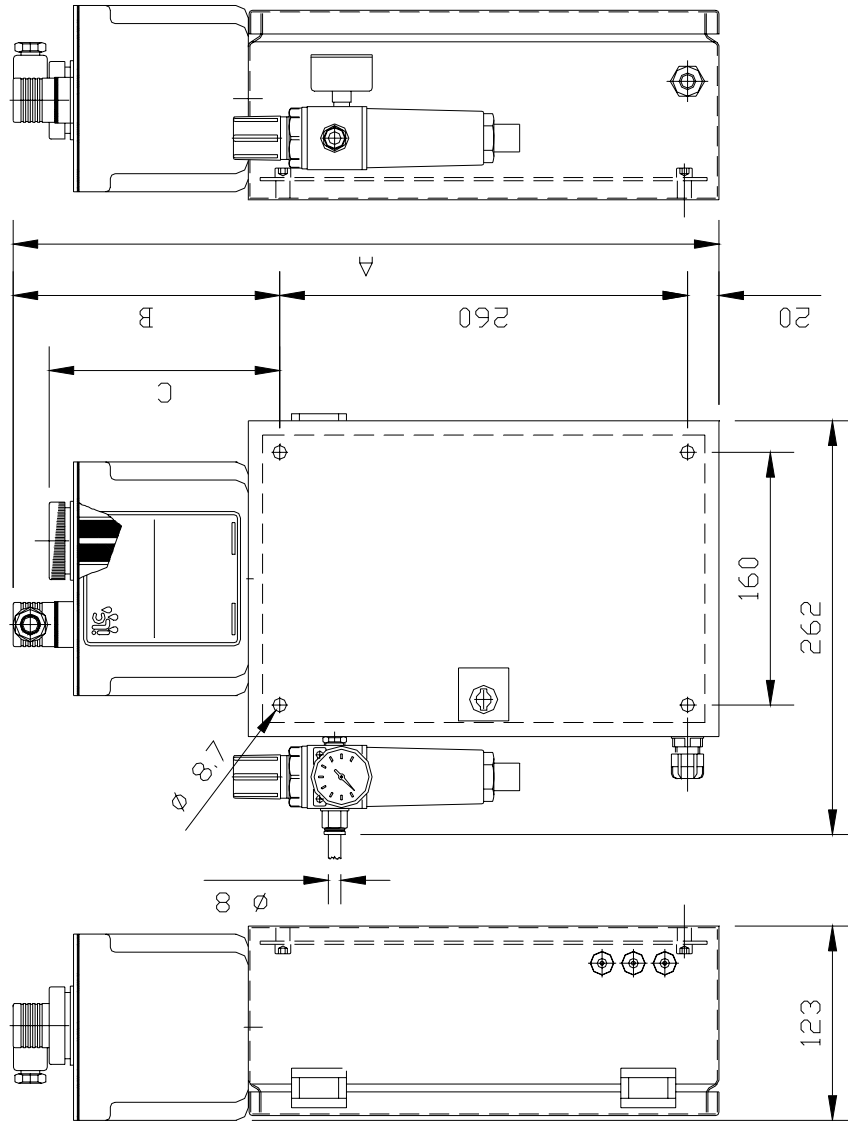

SERBATOIO RESERVOIR	A	B	C
1.2 L	450	170	147
2.2 L	502	222	199



MC-EL-2P

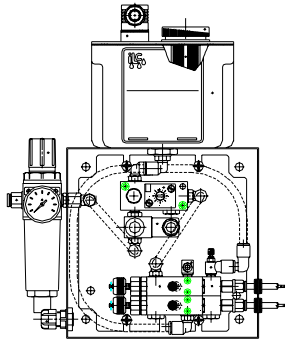

L'UNITA' E' FORNITA COMPLETA DI:

- SERBATOIO 1.2 L O 2.2 L
- LIVELLO ELETTRICO: 1 A 250 V AC 200 V DC 50 W
- POMPE DA 1 A 2
- 5 M TUBO COASSIALE PER OGNI USCITA (6 MM – 2.5 MM)
- SCATOLA DI PROTEZIONE METALLICA
- L'ELETTRORVALVOLA VA ORDINATA A PARTE
CODICE 14.660.0
- REGOLATORE D'ARIA
- RIDUTTORE + MANOMETRO
- GENERATORE DI FREQUENZA

THE UNIT IS SUPPLIED COMPLETE OF:

- RESERVOIR 1.2 L OR 2.2 L
- LOW LEVEL SWITCH: 1 A 250 V AC 200 V DC 50 W
- PUMPS FROM 1 TO 2
- 5 M COAXIAL FEEDING LINES FOR EACH OUTLET (6 MM – 2.5 MM)
- METALLIC BOX
- THE SOLENOID VALVE HAS TO BE ORDERED SEPARATELY
CODE 14.660.0
- AIR REGULATOR
- AIR REDUCER + GAUGE
- FREQUENCY GENERATOR

CODICI DI ORDINAZIONE – CODES FOR ORDER

CODICE CODE	MODELLO TYPE	NUMERO DI POMPE PUMPS NUMBER
70.050.3	MC-EL-2P-1.2-1	1
70.050.4	MC-EL-2P-2.2-1	1
70.050.5	MC-EL-2P-1.2-2	2
70.050.6	MC-EL-2P-2.2-2	2
70.050.3.SL	MC-EL-2P-1.2-1-SL	1
70.050.4.SL	MC-EL-2P-2.2-1-SL	1
70.050.5.SL	MC-EL-2P-1.2-2-SL	2
70.050.6.SL	MC-EL-2P-2.2-2-SL	2

SL SIGNIFICA CHE L'UNITA' E' FORNITA SENZA LIVELLO ELETTRICO
SL MEANS THAT THE UNIT WILL BE DELIVERED WITHOUT LOW LEVEL SWITCH

CODICI PER ORDINARE BOBINE DELL'ELETTRORVALVOLA – CODES TO ORDER SOLENOID VALVE COILS

14.660.1.R	14.660.2.R	14.660.3.R	14.660.4.R
24 V DC	115 V AC	230 V AC	24 V AC



MC-EL-2M

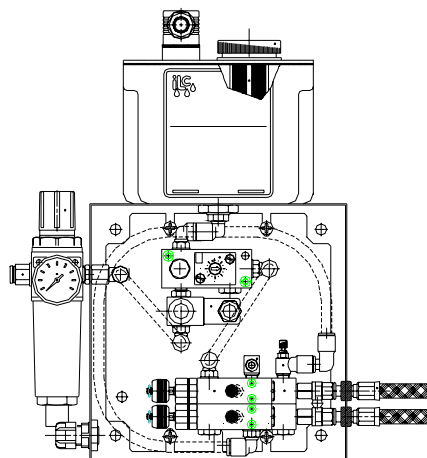

L'UNITA' E' FORNITA COMPLETA DI:

- SERBATOIO 1.2 L O 2.2 L
- LIVELLO ELETTRICO: 1 A 250 V AC 200 V DC 50 W
- POMPE DA 1 A 2
- TUBO COASSIALE METALLICO DA ORDINARE A PARTE CON CODULO DA 8 MM. VEDI PAGINA 101
- SCATOLA DI PROTEZIONE METALLICA
- L'ELETTRIVALVOLA VA ORDINATA A PARTE CODICE 14.660.0
- REGOLATORE D'ARIA
- RIDUTTORE + MANOMETRO
- GENERATORE DI FREQUENZA

THE UNIT IS SUPPLIED COMPLETE OF:

- RESERVOIR 1.2 L OR 2.2 L
- LOW LEVEL SWITCH: 1 A 250 V AC 200 V DC 50 W
- PUMPS FROM 1 TO 2
- COAXIAL FEEDING LINES (METALLIC COVERING). MUST BE ORDERED SEPARATELY WITH 8 MM TERMINAL. SEE PAGE 101
- METALLIC BOX
- THE SOLENOID VALVE HAS TO BE ORDERED SEPARATELY CODE 14.660.0
- AIR REGULATOR
- AIR REDUCER + GAUGE
- FREQUENCY GENERATOR

CODICI DI ORDINAZIONE – CODES FOR ORDER

CODICE CODE	MODELLO TYPE	NUMERO DI POMPE PUMPS NUMBER
70.050.1	MC-EL-2M-1.2-1	1
70.051.1	MC-EL-2M-2.2-1	1
70.050.2	MC-EL-2M-1.2-2	2
70.051.2	MC-EL-2M-2.2-2	2
70.050.1.SL	MC-EL-2M-1.2-1-SL	1
70.051.1.SL	MC-EL-2M-2.2-1-SL	1
70.050.2.SL	MC-EL-2M-1.2-2-SL	2
70.051.2.SL	MC-EL-2M-2.2-2-SL	2

SL: L'UNITA' E' FORNITA SENZA LIVELLO ELETTRICO SL: THE UNIT WILL BE DELIVERED WITHOUT LOW LEVEL SWITCH

CODICI PER ORDINARE BOBINE DELL'ELETTRIVALVOLA – CODES TO ORDER SOLENOID VALVE COILS

14.660.1.R	14.660.2.R	14.660.3.R	14.660.4.R
24 V DC	115 V AC	230 V AC	24 V AC

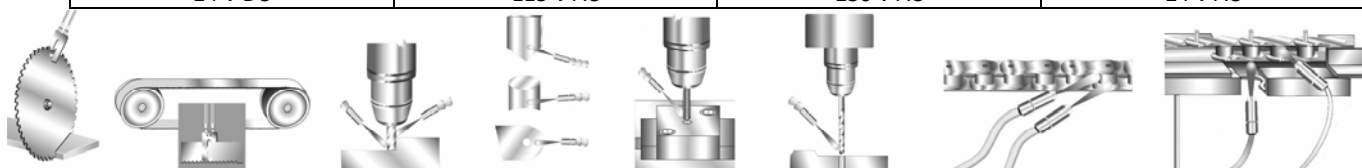

DIMENSIONI D'INGOMBRO

OVERALL DIMENSION

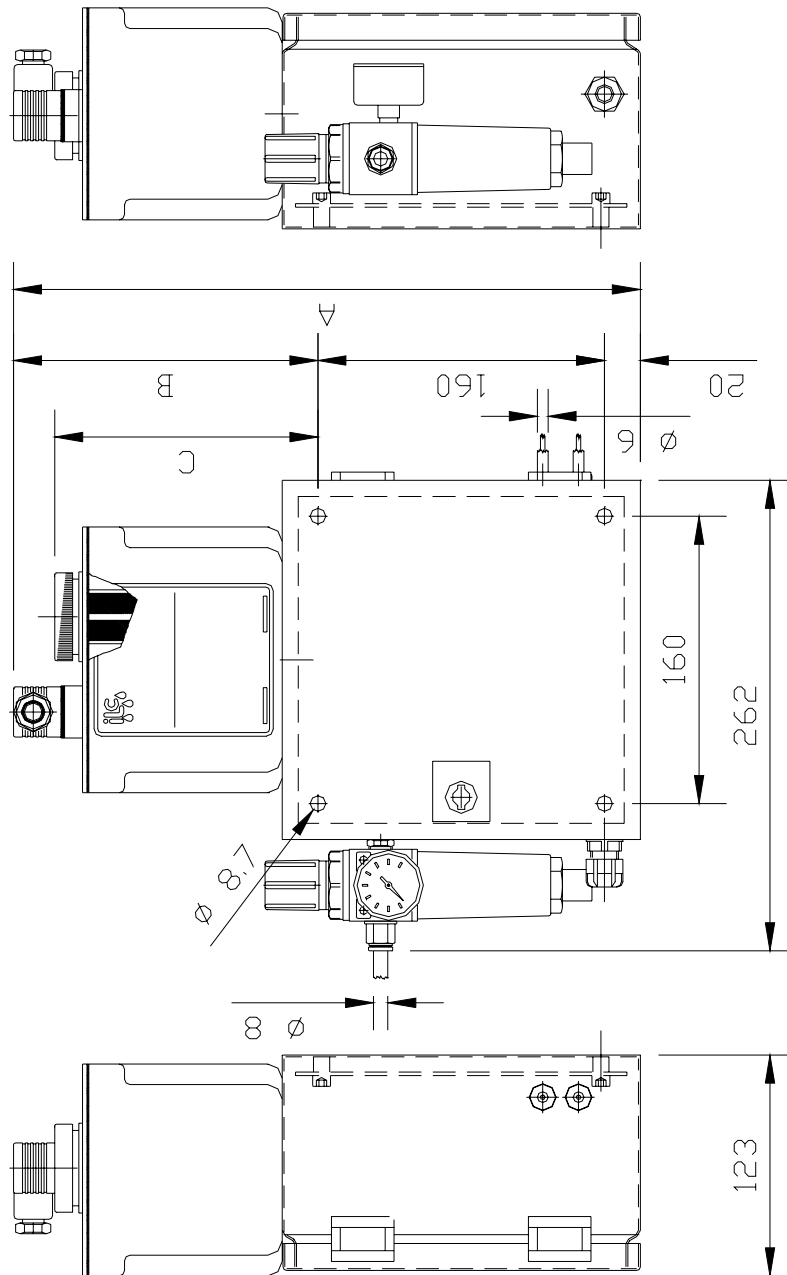

SERBATOIO RESERVOIR	A	B	C
1.2 L	350	170	147
2.2 L	402	222	199



MC-EL-2P-SS

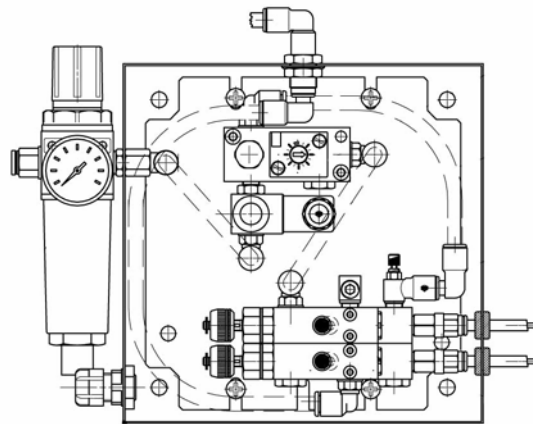

L'UNITA' E' FORNITA COMPLETA DI:

- POMPE DA 1 A 2
- TUBO COASSIALE 5 M PER OGNI USCITA (6 MM – 2.5 MM)
- SCATOLA DI PROTEZIONE METALLICA
- L'ELETTROVALVOLA VA ORDINATA A PARTE
CODICE 14.660.0
- REGOLATORE D'ARIA
- RIDUTTORE + MANOMETRO
- GENERATORE DI FREQUENZA
- IL SERBATOIO DEV'ESSERE ORDINATO A PARTE (VEDI PAG. 88)

THE UNIT IS SUPPLIED COMPLETE OF:

- PUMPS FROM 1 TO 2
- 5M COAXIAL FEEDING LINES EVERY OUTLET (6 MM – 2.5 MM)
- METALLIC BOX
- THE SOLENOID VALVE HAS TO BE ORDERED SEPARATELY
CODE 14.660.0
- AIR REGULATOR
- AIR REDUCER + GAUGE
- FREQUENCY GENERATOR
- RESERVOIR HAS TO BE ORDERED SEPARATELY (SEE PAG. 88)

CODICI DI ORDINAZIONE – CODES FOR ORDER

CODICE CODE	MODELLO TYPE	NUMERO DI POMPE PUMPS NUMBER
70.719.1	MC-EL-1P-SS	1
70.718.6	MC-EL-2P-SS	2

CODICI PER ORDINARE BOBINE DELL'ELETTROVALVOLA – CODES TO ORDER SOLENOID VALVE COILS

14.660.1.R	14.660.2.R	14.660.3.R	14.660.4.R
24 V DC	115 V AC	230 V AC	24 V AC



DIMENSIONI D'INGOMBRO

OVERALL DIMENSION

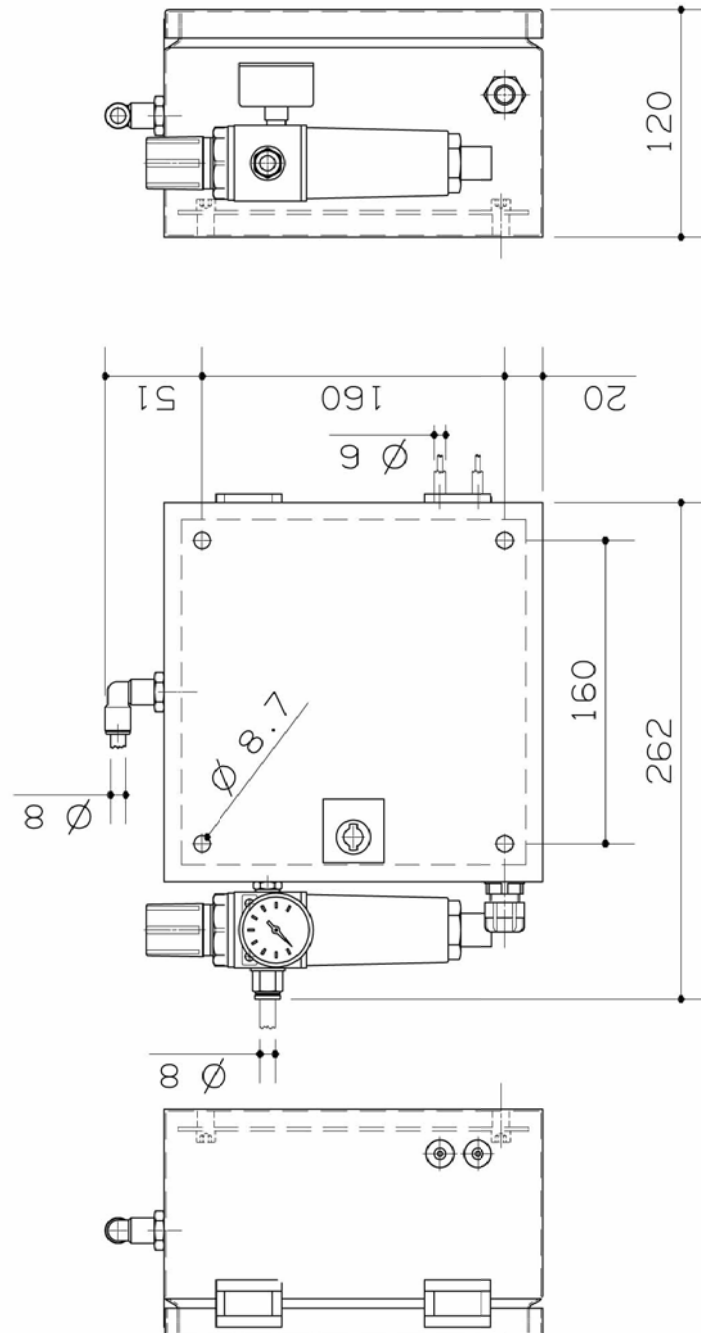

MC-EL-3P-4P-5P-6P-7P

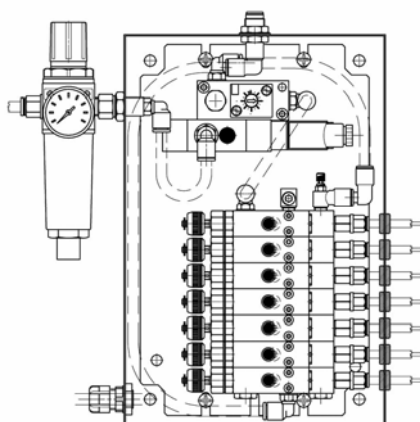

L'UNITA' E' FORNITA COMPLETA DI:

- POMPE DA 3 A 7
- TUBO COASSIALE 5 M PER OGNI USCITA (6 MM – 2.5 MM)
- SCATOLA DI PROTEZIONE METALLICA
- L'ELETTRIVALVOLA VA ORDINATA A PARTE
CODICE 14.660.0
- REGOLATORE D'ARIA
- RIDUTTORE + MANOMETRO
- GENERATORE DI FREQUENZA
- IL SERBATOIO DEV'ESSERE ORDINATO A PARTE (VEDI PAG. 88)

THE UNIT IS SUPPLIED COMPLETE OF:

- PUMPS FROM 3 TO 7
- 5M COAXIAL FEEDING LINES EVERY OUTLET (6 MM – 2.5 MM)
- METALLIC BOX
- THE SOLENOID VALVE HAS TO BE ORDERED SEPARATELY
CODE 14.660.0
- AIR REGULATOR
- AIR REDUCER + GAUGE
- FREQUENCY GENERATOR
- RESERVOIR HAS TO BE ORDERED SEPARATELY (SEE PAG. 88)

CODICI DI ORDINAZIONE – CODES FOR ORDER

CODICE CODE	MODELLO TYPE	NUMERO DI POMPE PUMPS NUMBER
70.705.3	MC-EL-3P	3
70.705.4	MC-EL-4P	4
70.705.5	MC-EL-5P	5
70.705.6	MC-EL-6P	6
70.705.7	MC-EL-7P	7

CODICI PER ORDINARE BOBINE DELL'ELETTRIVALVOLA – CODES TO ORDER SOLENOID VALVE COILS

14.660.1.R	14.660.2.R	14.660.3.R	14.660.4.R
24 V DC	115 V AC	230 V AC	24 V AC



DIMENSIONI D'INGOMBRO

OVERALL DIMENSION

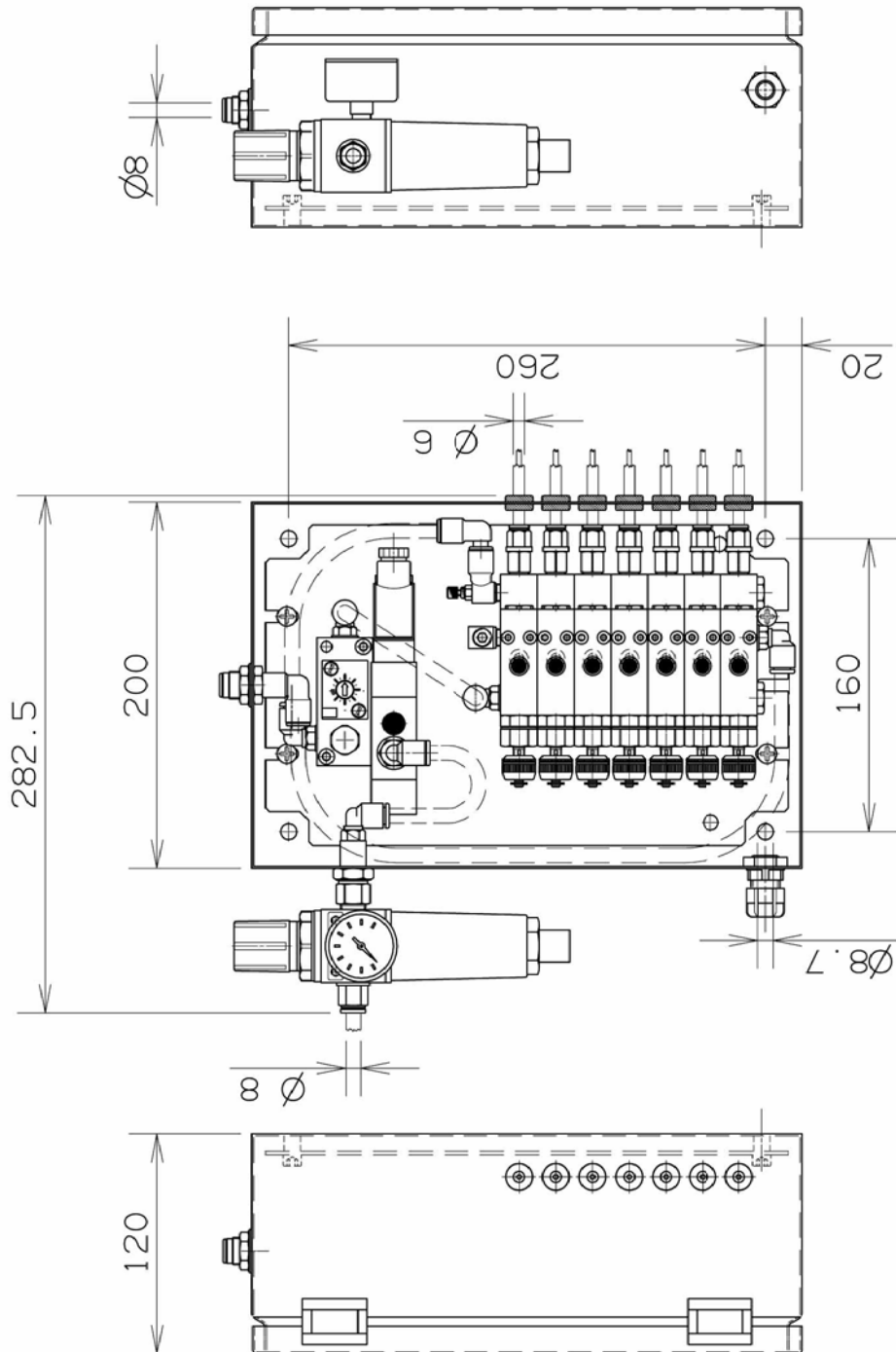

MC-EL-6L-3P-4P-5P-6P-7P-8P

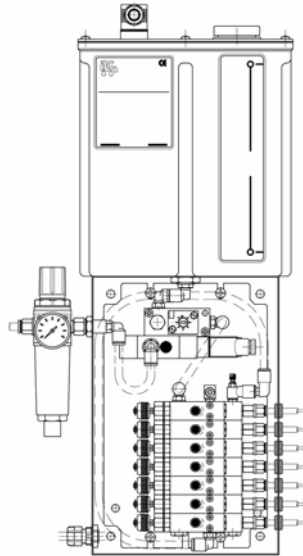

L'UNITA' E' FORNITA COMPLETA DI:

LIVELLO ELETTRICO: 1 A 250 V AC 200 V DC 50 W
 POMPE DA 3 A 8
 TUBO COASSIALE 5 M PER OGNI USCITA (6 MM – 2.5 MM)
 SCATOLA DI PROTEZIONE METALLICA
 L'ELETTRIVALVOLA VA ORDINATA A PARTE
 CODICE 14.660.0
 REGOLATORE D'ARIA
 RIDUTTORE + MANOMETRO
 GENERATORE DI FREQUENZA

THE UNIT IS SUPPLIED COMPLETE OF:

LOW LEVEL SWITCH: 1 A 250 V AC 200 V DC 50 W
 PUMPS FROM 3 TO 8
 5M COAXIAL FEEDING LINES EVERY OUTLET (6 MM – 2.5 MM)
 METALLIC BOX
 THE SOLENOID VALVE HAS TO BE ORDERED SEPARATELY
 CODE 14.660.0
 AIR REGULATOR
 AIR REDUCER + GAUGE
 FREQUENCY GENERATOR

CODICI DI ORDINAZIONE – CODES FOR ORDER

CODICE CODE	MODELLO TYPE	NUMERO DI POMPE PUMPS NUMBER	CODICE CODE	MODELLO TYPE	NUMERO DI POMPE PUMPS NUMBER
70.704.3	MC-EL-6L-3P	3	70.704.3.SL	MC-EL-6L-3P-SL	3
70.704.4	MC-EL-6L-4P	4	70.704.4.SL	MC-EL-6L-4P-SL	4
70.704.5	MC-EL-6L-5P	5	70.704.5.SL	MC-EL-6L-5P-SL	5
70.704.6	MC-EL-6L-6P	6	70.704.6.SL	MC-EL-6L-6P-SL	6
70.704.7	MC-EL-6L-7P	7	70.704.7.SL	MC-EL-6L-7P-SL	7
70.730.7	MC-EL-6L-8P	8	70.730.7.SL	MC-EL-6L-8P-SL	8
SL: L'UNITA' E' FORNITA SENZA LIVELLO ELETTRICO			SL: THE UNIT WILL BE DELIVERED WITHOUT LOW LEVEL SWITCH		

CODICI PER ORDINARE BOBINE DELL'ELETTRIVALVOLA – CODES TO ORDER SOLENOID VALVE COILS

14.660.1.R	14.660.2.R	14.660.3.R	14.660.4.R
24 V DC	115 V AC	230 V AC	24 V AC

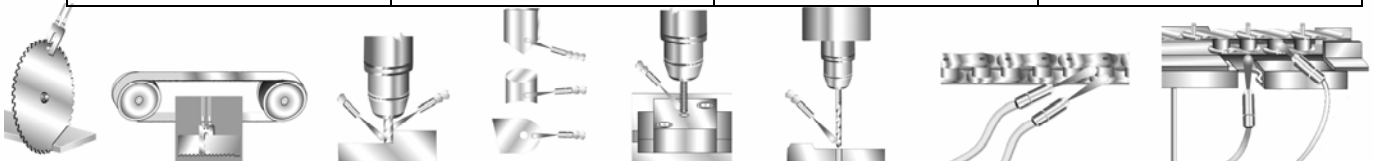

DIMENSIONI D'INGOMBRO

OVERALL DIMENSION

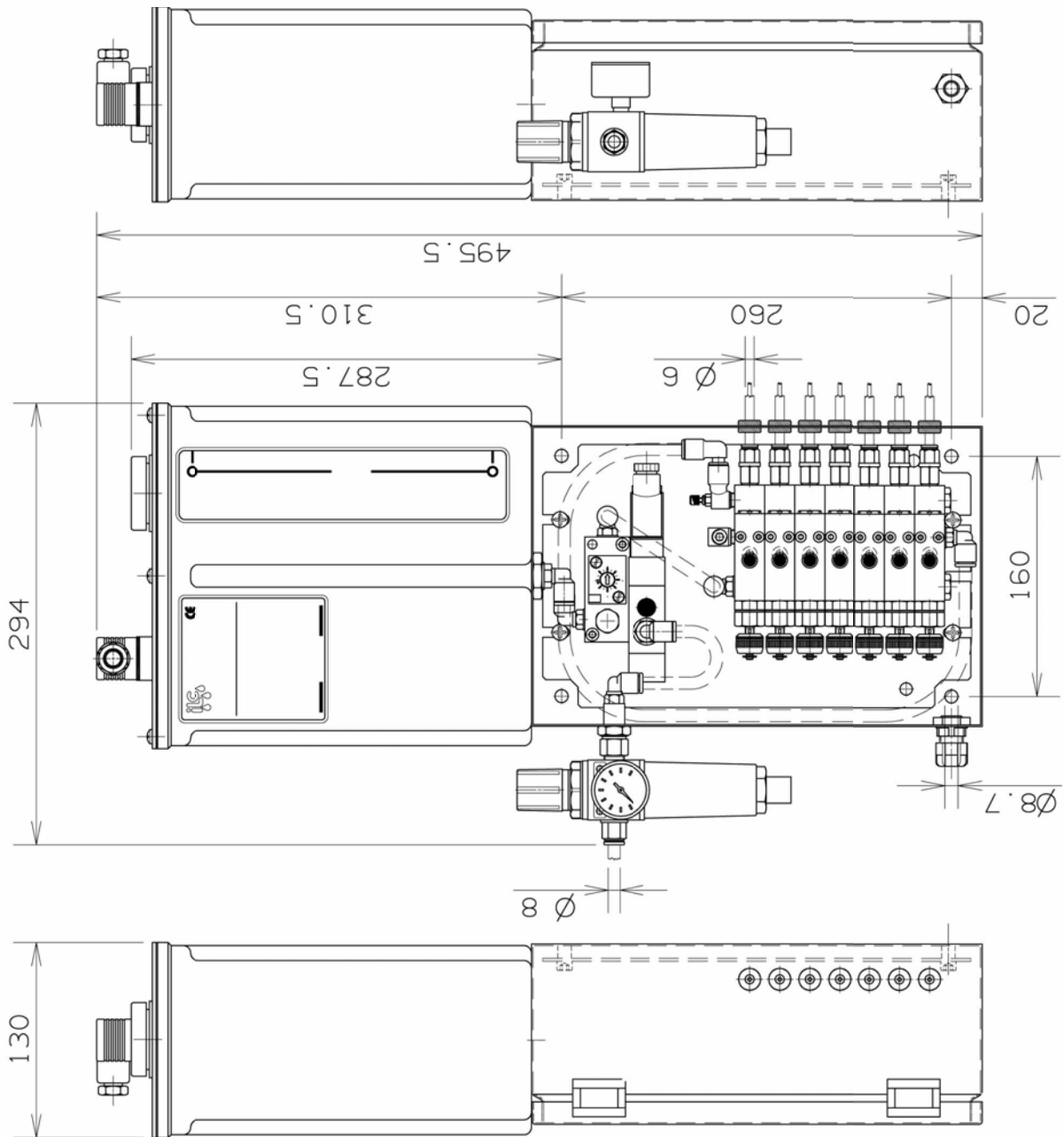

**UNITA' LUBETOOL MINI-GF-EL, MINI-GF, MINI-SG-EL, MINI-SG,
MINI-035-WFG E MINI-035-FG**

**LUBETOOL MINI-GF-EL, MINI-GF, MINI-SG-EL, MINI-SG, MINI-
035-WFG E MINI-035-FG**

SONO FORNITI SENZA SCATOLA DI PROTEZIONE

THEY ARE SUPPLIED WITHOUT BOX

CARATTERISTICHE		FEATURES	
PORTATA	DA 0 MM ³ A 41 MM ³	DISCHARGE	FROM 0 MM ³ TO 41 MM ³
POMPE	DA 1 A 2	PUMPS	FROM 1 TO 2
ELETTRIVALVOLA	24 V DC – 24 V AC – 115 V AC – 230 V AC	SOLENOID VALVE	24 V DC – 24 V AC – 115 V AC – 230 V AC
CORSE	DA 3 AL SECONDO A 1 AL MINUTO	STROKES	FROM 3 /SECOND TO 1 / MINUTE
SERBATOIO	0.5 L, 1.2 L, 2.2 L O 3.6 L	RESERVOIR	0.5 L, 1.2 L, 2.2 L OR 3.6 L
LUBRIFICANTE	OLIO MAX 800 cSt 40 °C	LUBRICANT	OIL MAX 800 cSt 40 °C
LIVELLO ELETTRICO	1 A 250 V AC – 220 V DC – 50 W	LOW LEVEL SWITCH	1 A 250 V AC – 220 V DC – 50 W
PRESSIONE ARIA	DA 4 BAR A 8 BAR	AIR PRESSURE	FROM 4 BAR TO 8 BAR
CONSUMO ARIA PER PUNTO A 6 BAR	MIN: 60 L/M – MAX 100 L/M	AIR CONSUME AT 6 BAR/POINT	MIN: 60 L/M – MAX 100 L/M



MINI-GF-EL

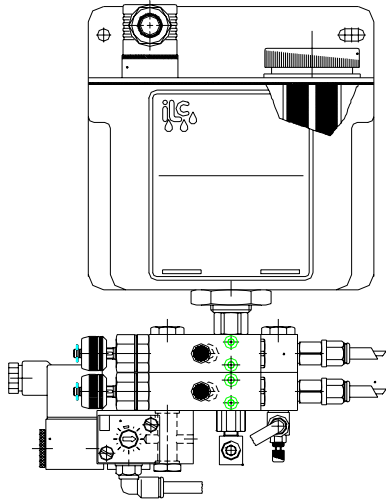

L'UNITA' E' FORNITA COMPLETA DI:

- SERBATOIO 1.2 L, 2.2 L O 3.6 L
- LIVELLO ELETTRICO: 1 A 250 V AC 200 V DC 50 W
- POMPE DA 1 A 2
- 5 M TUBO COASSIALE PER OGNI USCITA (6 MM – 2.5 MM)
- ELETTROVALVOLA 24 V DC – 24 V AC – 115 V AC O 230 V AC
LA TENSIONE DEVE ESSERE AGGIUNTA AL CODICE. ESEMPIO
70.015.0.24VDC
- REGOLATORE D'ARIA
- GENERATORE DI FREQUENZA

THE UNIT IS SUPPLIED COMPLETE OF:

- RESERVOIR 1.2 L, 2.2 L OR 3.6 L
- LOW LEVEL SWITCH: 1 A 250 V AC 200 V DC 50 W
- PUMPS FROM 1 TO 2
- 5 M COAXIAL FEEDING LINES FOR EACH OUTLET (6 MM – 2.5 MM)
- SOLENOID VALVE 24 V DC – 24 V AC – 115 V AC OR 230 V AC
THE VOLTAGE HAS TO BE ADD TO THE CODE. EXAMPLE
70.015.0.24VDC
- AIR REGULATOR
- FREQUENCY GENERATOR

CODICI DI ORDINAZIONE – CODES FOR ORDER

CODICE CODE	MODELLO TYPE	NUMERO DI POMPE PUMPS NUMBER	CODICE CODE	MODELLO TYPE	NUMERO DI POMPE PUMPS NUMBER
70.015.0	MINI-GF-EL-1/1.2 L	1	70.015.0.SL	MINI-GF-EL-1/1.2 L-SL	1
70.020.0	MINI-GF-EL-2/1.2 L	2	70.020.0.SL	MINI-GF-EL-2/1.2 L-SL	2
70.015.1	MINI-GF-EL-1/2.2 L	1	70.015.1.SL	MINI-GF-EL-1/2.2 L-SL	1
70.020.1	MINI-GF-EL-2/2.2 L	2	70.020.1.SL	MINI-GF-EL-2/2.2 L-SL	2
70.015.2	MINI-GF-EL-1/3.6 L	1	70.015.2.SL	MINI-GF-EL-1/3.6 L-SL	1
70.020.2	MINI-GF-EL-2/3.6 L	2	70.020.2.SL	MINI-GF-EL-2/3.6 L-SL	2

SL: L'UNITA' E' FORNITA SENZA LIVELLO ELETTRICO SL: THE UNIT WILL BE DELIVERED WITHOUT LOW LEVEL SWITCH

CODICI PER ORDINARE BOBINE DELL'ELETTROVALVOLA – CODES TO ORDER SOLENOID VALVE COILS

14.660.1.R	14.660.2.R	14.660.3.R	14.660.4.R
24 V DC	115 V AC	230 V AC	24 V AC



MINI-GF

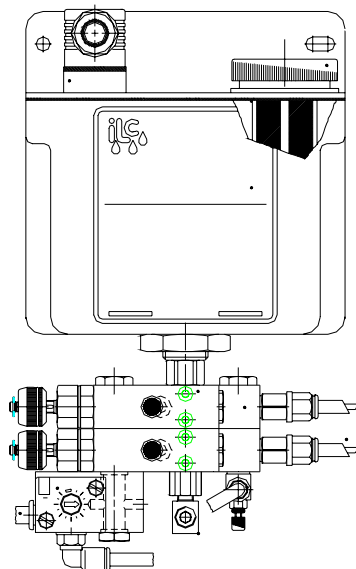

L'UNITA' E' FORNITA COMPLETA DI:

SERBATOIO 1.2 L, 2.2 L O 3.6 L

LIVELLO ELETTRICO: 1 A 250 V AC 200 V DC 50 W

POMPE DA 1 A 2

5 M TUBO COASSIALE PER OGNI USCITA (6 MM – 2.5 MM)

REGOLATORE D'ARIA

GENERATORE DI FREQUENZA

THE UNIT IS SUPPLIED COMPLETE OF:

RESERVOIR 1.2 L, 2.2 L OR 3.6 L

LOW LEVEL SWITCH: 1 A 250 V AC 200 V DC 50 W

PUMPS FROM 1 TO 2

5 M COAXIAL FEEDING LINES FOR EACH OUTLET (6 MM – 2.5 MM)

AIR REGULATOR

FREQUENCY GENERATOR

CODICI DI ORDINAZIONE – CODES FOR ORDER

CODICE CODE	MODELLO TYPE	NUMERO DI POMPE PUMPS NUMBER	CODICE CODE	MODELLO TYPE	NUMERO DI POMPE PUMPS NUMBER
70.004.0	MINI-GF-1/1.2 L	1	70.004.0.SL	MINI-GF-1/1.2 L-SL	1
70.004.1	MINI-GF-2/1.2 L	2	70.004.1.SL	MINI-GF-2/1.2 L-SL	2
70.004.2	MINI-GF-1/2.2 L	1	70.004.2.SL	MINI-GF-1/2.2 L-SL	1
70.004.3	MINI-GF-2/2.2 L	2	70.004.3.SL	MINI-GF-2/2.2 L-SL	2
70.004.4	MINI-GF-1/3.6 L	1	70.004.4.SL	MINI-GF-1/3.6 L-SL	1
70.004.5	MINI-GF-2/3.6 L	2	70.004.5.SL	MINI-GF-2/3.6 L-SL	2
SL SIGNIFICA CHE L'UNITA' E' FORNITA SENZA LIVELLO ELETTRICO			SL MEANS THAT THE UNIT WILL BE DELIVERED WITHOUT LOW LEVEL SWITCH		



DIMENSIONI D'INGOMBRO MINI-GF-EL

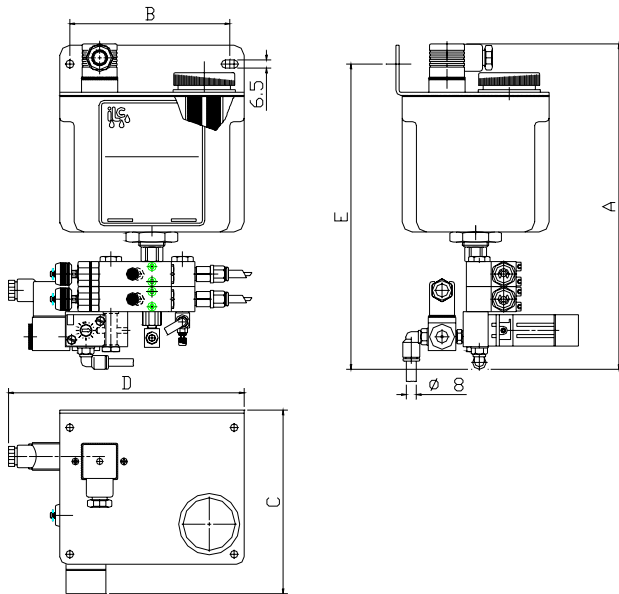

OVERALL DIMENSION MINI-GF-EL

POMPE PUMPS	SERBATOIO RESERVOIR	A	B	C	D	E
1	1.2 L	240	129	146	190	224
2	1.2 L	260	129	146	190	244
1	2.2 L	292	129	146	190	276
2	2.2 L	312	129	146	190	296
1	3.6 L	287	173	153	230	271
2	3.6 L	307	173	153	230	291

DIMENSIONI D'INGOMBRO MINI-GF

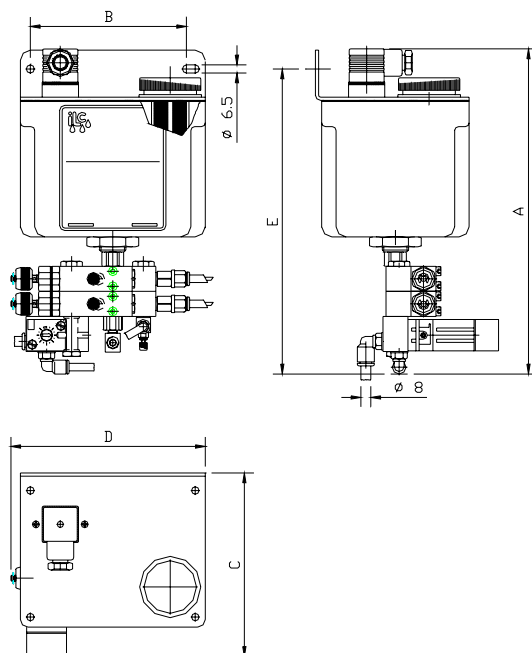

OVERALL DIMENSION MINI-GF

POMPE PUMPS	SERBATOIO RESERVOIR	A	B	C	D	E
1	1.2 L	260	129	147	155	244
2	1.2 L	280	129	147	155	264
1	2.2 L	312	129	147	155	296
2	2.2 L	332	129	147	155	316
1	3.6 L	307	173	153	230	291
2	3.6 L	327	173	153	230	311



MINI-SG-EL

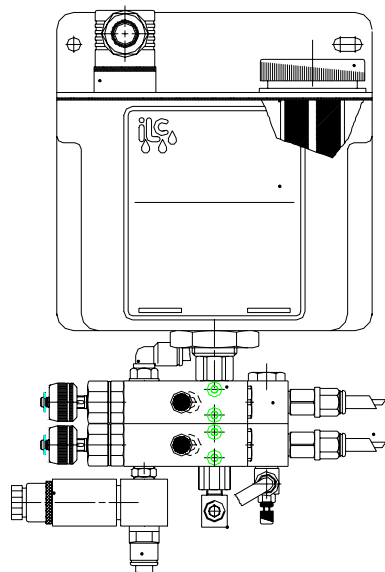

L'UNITA' E' FORNITA COMPLETA DI:

SERBATOIO 1.2 L, 2.2 L O 3.6 L

LIVELLO ELETTRICO: 1 A 250 V AC 200 V DC 50 W

POMPE DA 1 A 2

5 M TUBO COASSIALE PER OGNI USCITA (6 MM – 2.5 MM)

ELETTROVALVOLA 24 V DC – 24 V AC – 115 V AC O 230 V AC
LA TENSIONE DEVE ESSERE AGGIUNTA AL CODICE. ESEMPIO
70.017.0.24VDC

REGOLATORE D'ARIA

THE UNIT IS SUPPLIED COMPLETE OF:

RESERVOIR 1.2 L, 2.2 L OR 3.6 L

LOW LEVEL SWITCH: 1 A 250 V AC 200 V DC 50 W

PUMPS FROM 1 TO 2

5 M COAXIAL FEEDING LINES FOR EACH OUTLET (6 MM – 2.5 MM)

SOLENOID VALVE 24 V DC – 24 V AC – 115 V AC OR 230 V AC
THE VOLTAGE HAS TO BE ADD TO THE CODE. EXAMPLE
70.017.0.24VDC

AIR REGULATOR

CODICI DI ORDINAZIONE – CODES FOR ORDER

CODICE CODE	MODELLO TYPE	NUMERO DI POMPE PUMPS NUMBER	CODICE CODE	MODELLO TYPE	NUMERO DI POMPE PUMPS NUMBER
70.017.0	MINI-SG-EL-1/1.2 L	1	70.017.0.SL	MINI-SG-EL-1/1.2 L-SL	1
70.017.1	MINI-SG-EL-2/1.2 L	2	70.017.1.SL	MINI-SG-EL-2/1.2 L-SL	2
70.017.2	MINI-SG-EL-1/2.2 L	1	70.017.2.SL	MINI-SG-EL-1/2.2 L-SL	1
70.017.3	MINI-SG-EL-2/2.2 L	2	70.017.3.SL	MINI-SG-EL-2/2.2 L-SL	2
70.017.4	MINI-SG-EL-1/3.6 L	1	70.017.4.SL	MINI-SG-EL-1/3.6 L-SL	1
70.017.5	MINI-SG-EL-2/3.6 L	2	70.017.5.SL	MINI-SG-EL-2/3.6 L-SL	2
SL: L'UNITA' E' FORNITA SENZA LIVELLO ELETTRICO			SL: THE UNIT WILL BE DELIVERED WITHOUT LOW LEVEL SWITCH		

CODICI PER ORDINARE BOBINE DELL'ELETTROVALVOLA – CODES TO ORDER SOLENOID VALVE COILS

14.660.1.R	14.660.2.R	14.660.3.R	14.660.4.R
24 V DC	115 V AC	230 V AC	24 V AC



MINI-SG

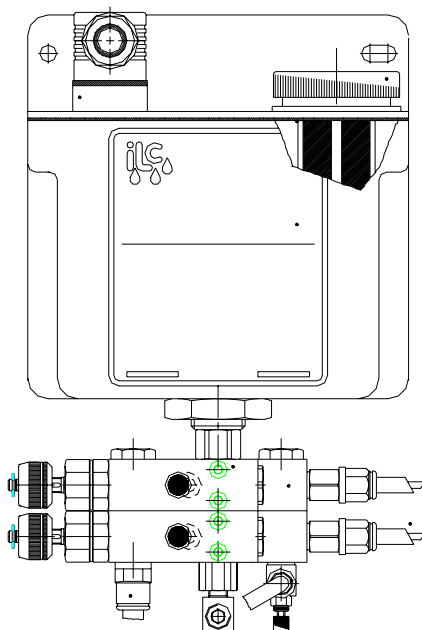

L'UNITA' E' FORNITA COMPLETA DI:

SERBATOIO 1.2 L, 2.2 L O 3.6 L

LIVELLO ELETTRICO: 1 A 250 V AC 200 V DC 50 W

POMPE DA 1 A 2

5 M TUBO COASSIALE PER OGNI USCITA (6 MM – 2.5 MM)

REGOLATORE D'ARIA

THE UNIT IS SUPPLIED COMPLETE OF:

RESERVOIR 1.2 L, 2.2 L OR 3.6 L

LOW LEVEL SWITCH: 1 A 250 V AC 200 V DC 50 W

PUMPS FROM 1 TO 2

5 M COAXIAL FEEDING LINES FOR EACH OUTLET (6 MM – 2.5 MM)

AIR REGULATOR

CODICI DI ORDINAZIONE – CODES FOR ORDER

CODICE CODE	MODELLO TYPE	NUMERO DI POMPE PUMPS NUMBER	CODICE CODE	MODELLO TYPE	NUMERO DI POMPE PUMPS NUMBER
70.005.0	MINI-SG-1/1.2 L	1	70.005.0.SL	MINI-SG-1/1.2 L-SL	1
70.005.1	MINI-SG-2/1.2 L	2	70.005.1.SL	MINI-SG-2/1.2 L-SL	2
70.005.2	MINI-SG-1/2.2 L	1	70.005.2.SL	MINI-SG-1/2.2 L-SL	1
70.005.3	MINI-SG-2/2.2 L	2	70.005.3.SL	MINI-SG-2/2.2 L-SL	2
70.005.4	MINI-SG-1/3.6 L	1	70.005.4.SL	MINI-SG-1/3.6 L-SL	1
70.005.5	MINI-SG-2/3.6 L	2	70.005.5.SL	MINI-SG-2/3.6 L-SL	2
SL SIGNIFICA CHE L'UNITA' E' FORNITA SENZA LIVELLO ELETTRICO			SL MEANS THAT THE UNIT WILL BE DELIVERED WITHOUT LOW LEVEL SWITCH		



DIMENSIONI D'INGOMBRO MINI-SG-EL

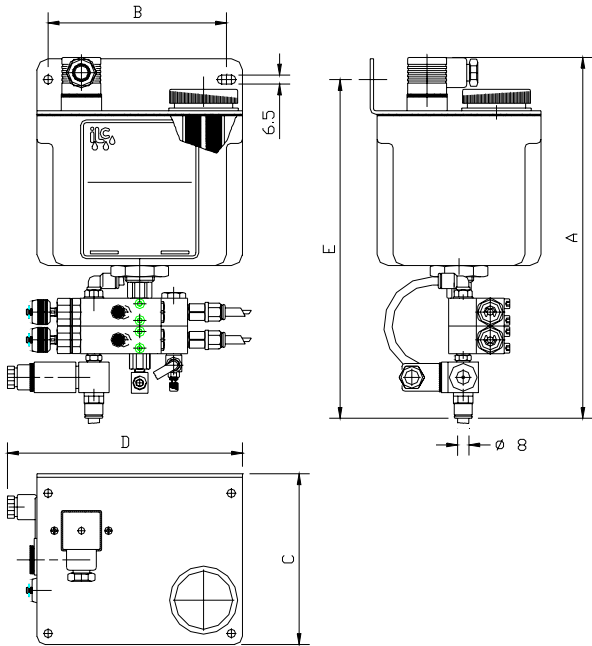

OVERALL DIMENSION MINI-SG-EL

POMPE PUMPS	SERBATOIO RESERVOIR	A	B	C	D	E
1	1.2 L	240	129	123	170	224
2	1.2 L	260	129	123	170	244
1	2.2 L	292	129	123	170	276
2	2.2 L	312	129	123	170	296
1	3.6 L	287	173	135	230	271
2	3.6 L	307	173	135	230	291

DIMENSIONI D'INGOMBRO MINI-SG

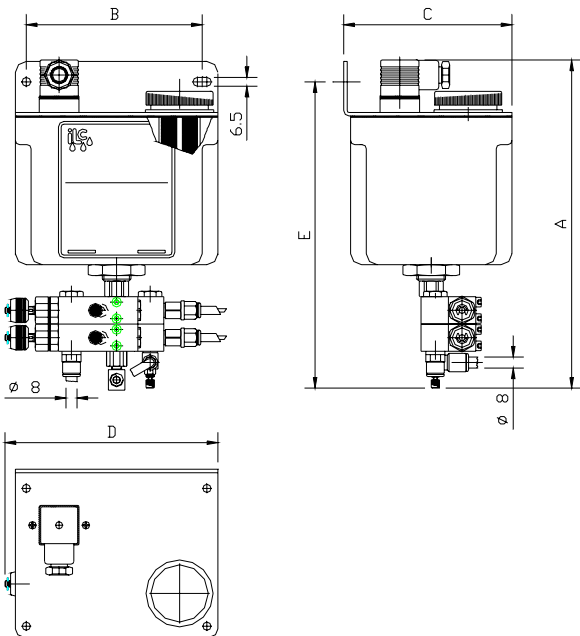

OVERALL DIMENSION MINI-SG

POMPE PUMPS	SERBATOIO RESERVOIR	A	B	C	D	E
1	1.2 L	220	129	123	155	204
2	1.2 L	240	129	123	155	224
1	2.2 L	272	129	123	155	256
2	2.2 L	292	129	123	155	276
1	3.6 L	215	173	135	230	251
2	3.6 L	235	173	135	230	271



MINI-GF-EL-SS

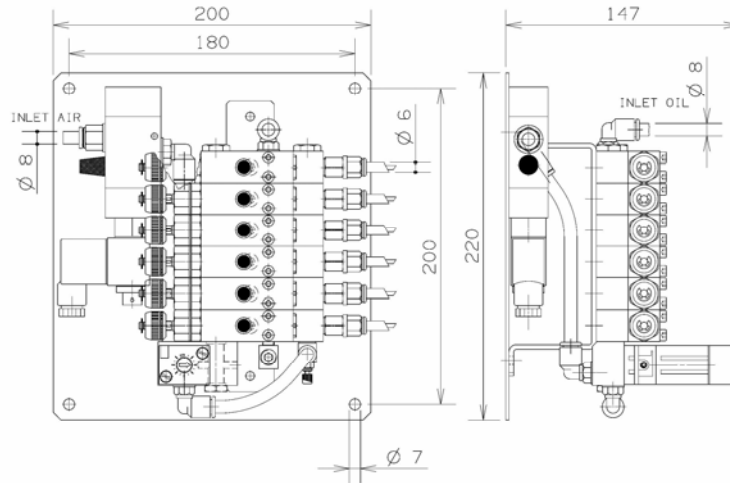

L'UNITA' E' FORNITA COMPLETA DI:

- POMPE DA 1 A 6
- TUBO COASSIALE 5 M PER OGNI USCITA (6 MM – 2.5 MM)
- L'ELETTRORVALVOLA VA ORDINATA A PARTE
CODICE 14.660.0
- REGOLATORE D'ARIA
- RIDUTTORE + MANOMETRO
- GENERATORE DI FREQUENZA
- IL SERBATOIO DEV'ESSERE ORDINATO A PARTE (VEDI PAG. 88)

THE UNIT IS SUPPLIED COMPLETE OF:

- PUMPS FROM 1 TO 6
- 5M COAXIAL FEEDING LINES EVERY OUTLET (6 MM – 2.5 MM)
- THE SOLENOID VALVE HAS TO BE ORDERED SEPARATELY
CODE 14.660.0
- AIR REGULATOR
- AIR REDUCER + GAUGE
- FREQUENCY GENERATOR
- RESERVOIR HAS TO BE ORDERED SEPARATELY (SEE PAG. 88)

CODICI DI ORDINAZIONE – CODES FOR ORDER

CODICE CODE	MODELLO TYPE	NUMERO DI POMPE PUMPS NUMBER
70.716.1	MINI-GF-EL-1P-SS	1
70.716.2	MINI-GF-EL-2P-SS	2
70.716.3	MINI-GF-EL-3P-SS	3
70.716.4	MINI-GF-EL-4P-SS	4
70.716.5	MINI-GF-EL-5P-SS	5
70.716.6	MINI-GF-EL-6P-SS	6

CODICI PER ORDINARE BOBINE DELL'ELETTRORVALVOLA – CODES TO ORDER SOLENOID VALVE COILS

14.660.1.R	14.660.2.R	14.660.3.R	14.660.4.R
24 V DC	115 V AC	230 V AC	24 V AC



MINI-SG-EL-SS

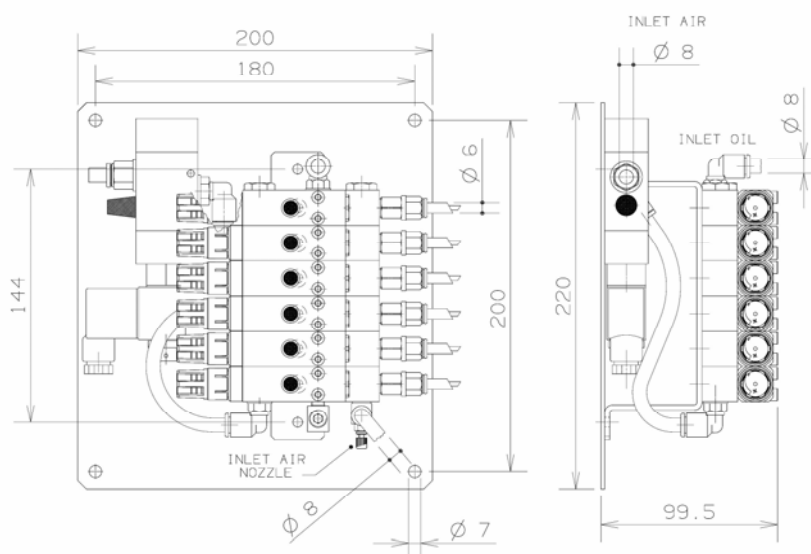

L'UNITA' E' FORNITA COMPLETA DI:

- POMPE DA 1 A 6
- TUBO COASSIALE 5 M PER OGNI USCITA (6 MM – 2.5 MM)
- L'ELETTROVALVOLA VA ORDINATA A PARTE
CODICE 14.660.0
- REGOLATORE D'ARIA
- RIDUTTORE + MANOMETRO
- IL SERBATOIO DEV'ESSERE ORDINATO A PARTE (VEDI PAG. 88)

THE UNIT IS SUPPLIED COMPLETE OF:

- PUMPS FROM 1 TO 6
- 5M COAXIAL FEEDING LINES EVERY OUTLET (6 MM – 2.5 MM)
- THE SOLENOID VALVE HAS TO BE ORDERED SEPARATELY
CODE 14.660.0
- AIR REGULATOR
- AIR REDUCER + GAUGE
- RESERVOIR HAS TO BE ORDERED SEPARATELY (SEE PAG. 88)

CODICI DI ORDINAZIONE – CODES FOR ORDER

CODICE CODE	MODELLO TYPE	NUMERO DI POMPE PUMPS NUMBER
70.716.1.SG	MINI-SG-EL-1P-SS	1
70.716.2.SG	MINI-SG-EL-2P-SS	2
70.716.3.SG	MINI-SG-EL-3P-SS	3
70.716.4.SG	MINI-SG-EL-4P-SS	4
70.716.5.SG	MINI-SG-EL-5P-SS	5
70.716.6.SG	MINI-SG-EL-6P-SS	6

CODICI PER ORDINARE BOBINE DELL'ELETTROVALVOLA – CODES TO ORDER SOLENOID VALVE COILS

14.660.1.R	14.660.2.R	14.660.3.R	14.660.4.R
24 V DC	115 V AC	230 V AC	24 V AC



MINI-035-WFG

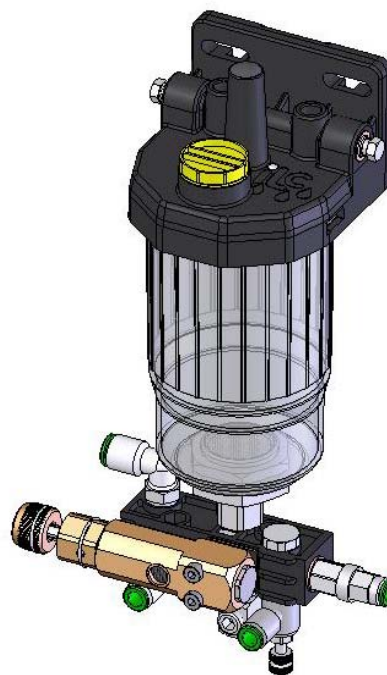
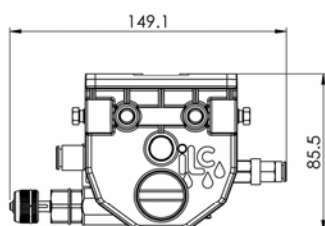
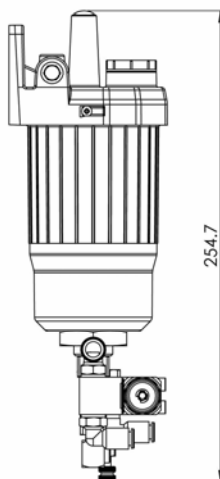
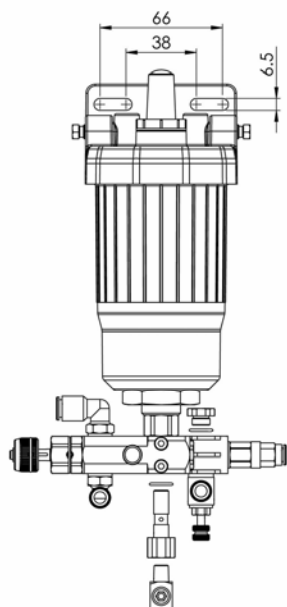

CODICE / CODE
70.055.0

SERBATOIO / RESERVOIR
0.5 L

L'UNITA' E' FORNITA COMPLETA DI:

- SERBATOIO 0.5 L
- 1 POMPA
- 5 M TUBO COASSIALE PER OGNI USCITA (6 MM – 2.5 MM)
- REGOLATORE D'ARIA

THE UNIT IS SUPPLIED COMPLETE OF:

- RESERVOIR 0.5 L
- 1 PUMP
- 5 M COAXIAL FEEDING LINES FOR EACH OUTLET (6 MM – 2.5 MM)
- AIR REGULATOR



MINI-035-FG

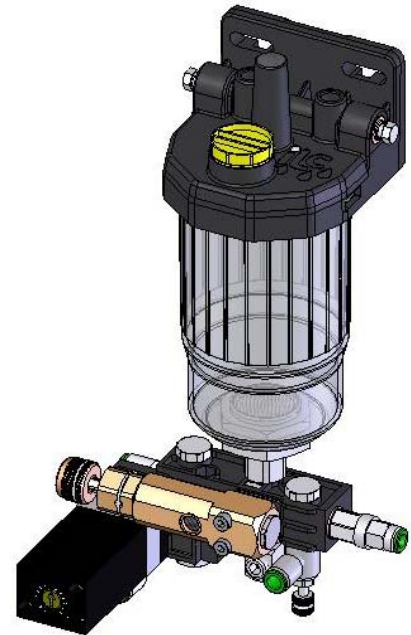
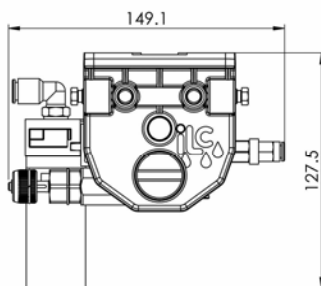
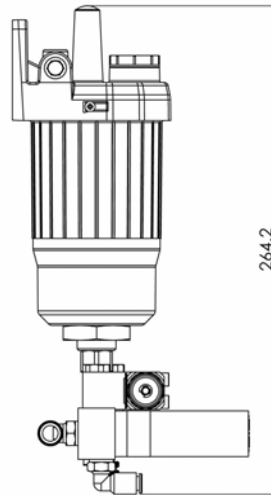
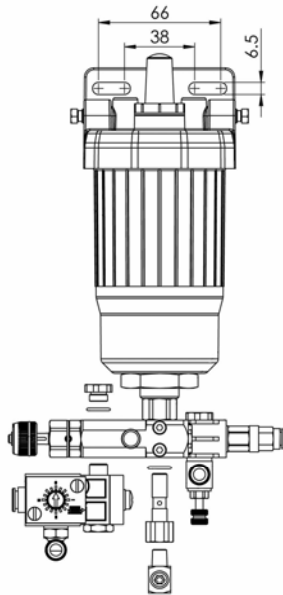

CODICE / CODE
70.055.1

SERBATOIO / RESERVOIR
0.5 L

L'UNITA' E' FORNITA COMPLETA DI:

- SERBATOIO 0.5 L
- 1 POMPA
- 5 M TUBO COASSIALE PER OGNI USCITA (6 MM – 2.5 MM)
- REGOLATORE D'ARIA
- GENERATORE DI FREQUENZA

THE UNIT IS SUPPLIED COMPLETE OF:

- RESERVOIR 0.5 L
- 1 PUMP
- 5 M COAXIAL FEEDING LINES FOR EACH OUTLET (6 MM – 2.5 MM)
- AIR REGULATOR
- FREQUENCY GENERATOR



UNITA' LUBETOOL MIX

LUBETOOL MIX

SONO STATE PROGETTATE PER LUBRIFICARE CON DUE LIQUIDI

THEY WERE DESIGNED TO LUBRICATE WITH TWO LIQUIDS

CARATTERISTICHE		FEATURES	
PORTATA	DA 0 MM ³ A 41 MM ³	DISCHARGE	FROM 0 MM ³ TO 41 MM ³
POMPE	DA 3 A 4	PUMPS	FROM 3 TO 4
ELETTRIVALVOLA	24 V DC – 24 V AC – 115 V AC – 230 V AC	SOLENOID VALVE	24 V DC – 24 V AC – 115 V AC – 230 V AC
CORSE	DA 3 AL SECONDO A 1 AL MINUTO	STROKES	FROM 3 /SECOND TO 1 / MINUTE
SERBATOIO	1.2 L, 2.2 L	RESERVOIR	1.2 L, 2.2 L
LUBRIFICANTE	OLIO MAX 800 cSt 40 °C	LUBRICANT	OIL MAX 800 cSt 40 °C
LIVELLO ELETTRICO	1 A 250 V AC – 220 V DC – 50 W	LOW LEVEL SWITCH	1 A 250 V AC – 220 V DC – 50 W
PRESSIONE ARIA	DA 4 BAR A 8 BAR	AIR PRESSURE	FROM 4 BAR TO 8 BAR
CONSUMO ARIA PER PUNTO A 6 BAR	MIN: 60 L/M – MAX 100 L/M	AIR CONSUME AT 6 BAR/POINT	MIN: 60 L/M – MAX 100 L/M



MIX CON CONTENITORE IN PLASTICA

QUESTE UNITA', PROGETTATE PER L'APPLICAZIONE IN CASI DI ELEVATA PRODUZIONE, TROVANO LA LORO COLLOCAZIONE IDEALE NELLE LINEE DI TAGLIO AUTOMATICHE A DISCO, SEGATRICI A DISCO/NASTRO PER TAGLI DI GRANDE DIAMETRO O DOVUNQUE E' RICHiesto UN PARTICOLARE ABBINAMENTO FRA LA MICRO LUBRIFICAZIONE TRADIZIONALE ED IL RAFFREDDAMENTO.

UNA LINEA DI MANDATA INVIA OLIO E LO SPRUZZA FRONTALMENTE NEI DENTI DELLA LAMA, LA SECONDA LINEA INVIA EMULSIONE E LO SPRUZZA NEI FIANCHI.

SI OTTENGONO NOTEVOLI VANTAGGI SIA NELLA QUALITA' DEL TAGLIO, SIA NELLA DURATA DELLA LAMA.

L'UNITA' PREVEDE UN SOLO COMANDO IN QUANTO LE DUE LINEE FUNZIONANO CONTEMPORANEAMENTE, MENTRE I DUE SERBATOI SONO SEPARATI.

L'UNITA' STANDARD VIENE FORNITA COMPLETA DI TUBI COASSIALI DA 5 M

A RICHIESTA E' POSSIBILE ESEGUIRE ESECUZIONI SPECIALI.

MIX WITH PLASTIC CONTAINER

THIS SYSTEM IS USED IN CASE OF HIGH PRODUCTION, TO CUT HIGH DIAMETERS AND WHERE IS NECESSARY TO USE THE MICRO LUBRIFICATION TOGETHER WITH THE TRADITIONAL LUBRICATION.

A LINE SEND OIL TO BE SPRAYED FRONTALLY ON THE TEETH AND A SECOND LINE SEND EMULSION TO BE SPRAYED ON THE SIDES.

AS A RESULT THERE IS AN HIGH CUT QUALITY AND A LONG LIFE TOOL.

THE UNIT NEED A UNIQUE DRIVE BECAUSE THE TWO LINES ARE WORKING IN THE SAME TIME AND THE TWO RESERVOIRS ARE SEPARATE.

THE STANDARD UNIT IS COMPLETE WITH 5 M COAXIAL HOSES.

ON REQUEST IT IS POSSIBLE TO HAVE DIFFERENT SOLUTION.

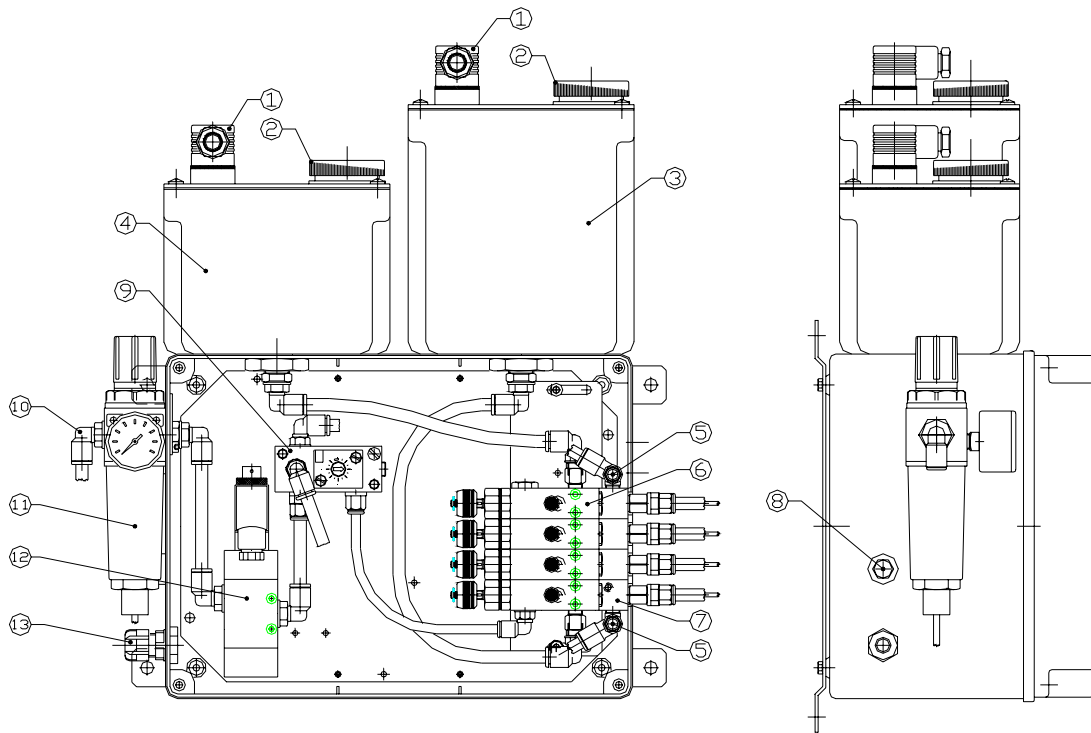

CODICI DI ORDINAZIONE – CODES FOR ORDER

CODICE CODE	MODELLO	TYPE
70.060.3	MIX 1 (OLIO) + 2 (EMULSIONE)	MIX 1 (OIL) + 2 (EMULSION)
70.060.4	MIX 2 (OLIO) +2 (EMULSIONE)	MIX 2 (OIL) +2 (EMULSION)



L'UNITA' E' FORNITA COMPLETA DI:		THE UNIT IS SUPPLIED COMPLETE OF:
1	LIVELLI ELETTRICI	LOW LEVEL SWITCHES
2	TAPPI DI RIEMPIMENTO CON FILTRO	FILLER CUPS + STRAINER
3	SERBATOIO 2.2 L PER EMULSIONE	RESERVOIR 2.2 L FOR EMULSION
4	SERBATOIO 1.2 L PER OLIO	RESERVOIR 1.2 L FOR OIL
5	REGOLATORI ARIA	AIR REGULATORS
6	POMPE 3 O 4	3 OR 4 PUMPS
7	BASI POMPE 3 O 4	3 OR 4 PUMP BASES
8	FILTRO SCARICO ARIA	STRAINER EXHAUST AIR
9	GENERATORE DI FREQUENZA	FREQUENCY GENERATOR
10	RACCORDO INGRESSO ARIA PUSH-IN 8 MM	AIR INLET FITTINGS PUSH-IN 8 MM
11	RIDUTTORE CON MANOMETRO	PRESSURE REDUCER WITH GAUGE
12	ELETTOVALVOLA 24 V DC – 24 V AC – 115 V AC O 230 V AC LA TENSIONE DEVE ESSERE AGGIUNTA AL CODICE. ESEMPIO 70.060.3.24VDC	SOLENOID VALVE 24 V DC – 24 V AC – 115 V AC OR 230 V AC THE VOLTAGE HAS TO BE ADD TO THE CODE. EXAMPLE 70.060.3.24VDC
13	PRESSACAVO	CABLE GLAND
5 M TUBO COASSIALE PER OGNI USCITA (6 MM – 2.5 MM)		5 M COAXIAL HOSE FOR EACH OUTLET (6 MM – 2.5 MM)

DIMENSIONI D'INGOMBRO

OVERALL DIMENSION

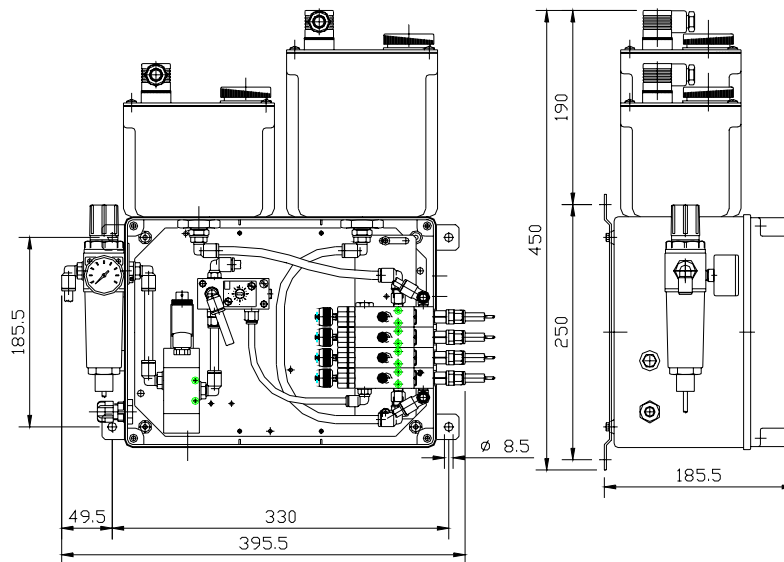

CODICI PER ORDINARE BOBINE DELL'ELETTOVALVOLA – CODES TO ORDER SOLENOID VALVE COILS

14.660.1.R	14.660.2.R	14.660.3.R	14.660.4.R
24 V DC	115 V AC	230 V AC	24 V AC



MIX CON CONTENITORE METALLICO

QUESTE UNITA', PROGETTATE PER L'APPLICAZIONE IN CASI DI ELEVATA PRODUZIONE, TROVANO LA LORO COLLOCAZIONE IDEALE NELLE LINEE DI TAGLIO AUTOMATICHE A DISCO, SEGATRICI A DISCO/NASTRO PER TAGLI DI GRANDE DIAMETRO O DOVUNQUE E' RICHiesto UN PARTICOLARE ABBINAMENTO FRA LA MICRO LUBRIFICAZIONE TRADIZIONALE ED IL RAFFREDDAMENTO.

UNA LINEA DI MANDATA INVIA OLIO E LO SPRUZZA FRONTALMENTE NEI DENTI DELLA LAMA, LA SECONDA LINEA INVIA EMULSIONE E LO SPRUZZA NEI FIANCHI.

SI OTTENGONO NOTEVOLI VANTAGGI SIA NELLA QUALITA' DEL TAGLIO, SIA NELLA DURATA DELLA LAMA.

L'UNITA' PREVEDE UN SOLO COMANDO IN QUANTO LE DUE LINEE FUNZIONANO CONTEMPORANEAMENTE, MENTRE I DUE SERBATOI SONO SEPARATI.

L'UNITA' STANDARD VIENE FORNITA COMPLETA DI TUBI COASSIALI DA 5 M

A RICHIESTA E' POSSIBILE ESEGUIRE ESECUZIONI SPECIALI.

MIX WITH METALLIC BOX

THIS SYSTEM IS USED IN CASE OF HIGH PRODUCTION, TO CUT HIGH DIAMETERS AND WHERE IS NECESSARY TO USE THE MICRO LUBRIFICATION TOGETHER WITH THE TRADITIONAL LUBRICATION.

A LINE SEND OIL TO BE SPRAYED FRONTALLY ON THE TEETH AND A SECOND LINE SEND EMULSION TO BE SPRAYED ON THE SIDES.

AS A RESULT THERE IS AN HIGH CUT QUALITY AND A LONG LIFE TOOL.

THE UNIT NEED A UNIQUE DRIVE BECAUSE THE TWO LINES ARE WORKING IN THE SAME TIME AND THE TWO RESERVOIRS ARE SEPARATE.

THE STANDARD UNIT IS COMPLETE WITH 5 M COAXIAL HOSES.

ON REQUEST IT IS POSSIBLE TO HAVE DIFFERENT SOLUTION.

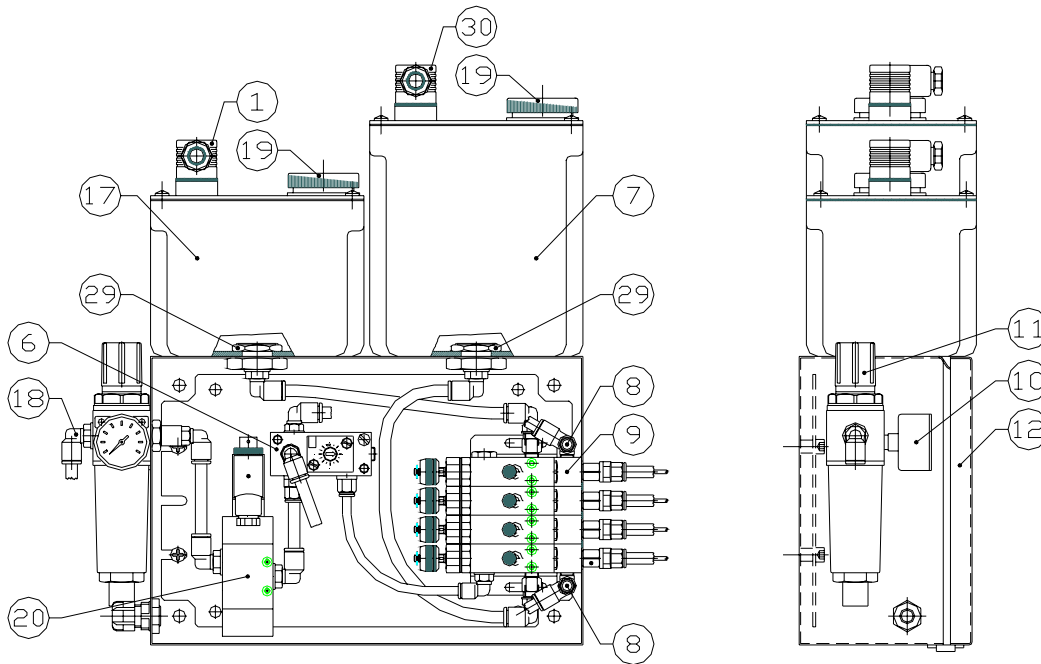

CODICI DI ORDINAZIONE – CODES FOR ORDER

CODICE CODE	MODELLO	TYPE
70.071.2	MIX 1 (OLIO) + 2 (EMULSIONE)	MIX 1 (OIL) + 2 (EMULSION)
70.071.3	MIX 2 (OLIO) +2 (EMULSIONE)	MIX 2 (OIL) +2 (EMULSION)



L'UNITA' E' FORNITA COMPLETA DI:		THE UNIT IS SUPPLIED COMPLETE OF:
1-30	LIVELLI ELETTRICI	LOW LEVEL SWITCHES
19	TAPPI DI RIEMPIMENTO CON FILTRO	FILLER CUPS + STRAINER
7	SERBATOIO 2.2 L PER EMULSIONE	2.2 L EMULSION RESERVOIR
17	SERBATOIO 1.2 L PER OLIO	1.2 L OIL RESERVOIR
12	CONTENITORE METALLICO	METALLIC BOX
9	POMPE + BASI	PUMPS + BASES
29	FILTRO ASPIRAZIONE	SUCTION STRAINER
8	REGOLATORI ARIA IMPIANTO	AIR REGULATOR
6	GENERATORE DI FREQUENZA	FREQUENCY GENERATOR
18	RACCORDO INGRESSO ARIA PUSH-IN 8 MM	AIR INLET FITTINGS PUSH-IN 8 MM
10-11	RIDUTTORE CON MANOMETRO	PRESSURE REDUCER WITH GAUGE
20	ELETTROVALVOLA 24 V DC – 24 V AC – 115 V AC O 230 V AC LA TENSIONE DEVE ESSERE AGGIUNTA AL CODICE. ESEMPIO 70.071.2.24VDC	SOLENOID VALVE 24 V DC – 24 V AC – 115 V AC OR 230 V AC THE VOLTAGE HAS TO BE ADD TO THE CODE. EXAMPLE 70.071.2.24VDC
5 M TUBO COASSIALE PER OGNI USCITA (6 MM – 2.5 MM)		5 M COAXIAL HOSE FOR EACH OUTLET (6 MM – 2.5 MM)

DIMENSIONI D'INGOMBRO

OVERALL DIMENSION

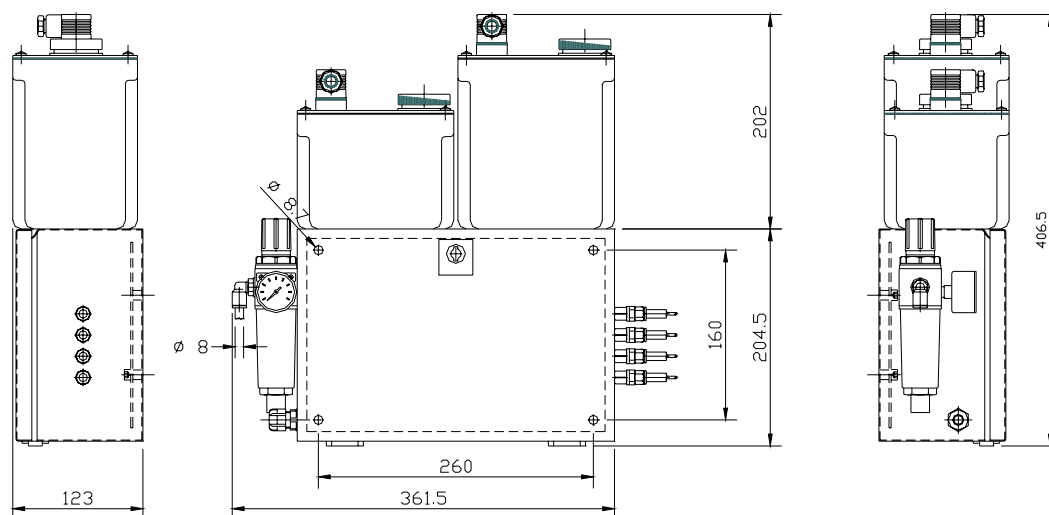

CODICI PER ORDINARE BOBINE DELL'ELETTROVALVOLA – CODES TO ORDER SOLENOID VALVE COILS

14.660.1.R	14.660.2.R	14.660.3.R	14.660.4.R
24 V DC	115 V AC	230 V AC	24 V AC



TUBI COASSIALI

TUTTI I LUBETOOLS VENGONO FORNITI CON 5 M DI TUBO COASSIALE ASSEMBLATO ALLE USCITE DELLE POMPE PNEUMATICHE. IL TUBO DI NYLON ESTERNO HA UN DIAMETRO DI 6 MM, MENTRE QUELLO INTERNO DI 2.5 MM. IL TUBO DI NYLON INTERNO E' PIU' LUNGO DI 500 MM RISPETTO A QUELLO ESTERNO POICHE' DEVE ESSERE COLLEGATO NELLA PARTE FINALE DEL TERMINALE CON UGELLO, MENTRE QUELLO ESTERNO NELLA PARTE INIZIALE. SU RICHIESTA E' POSSIBILE FORNIRE TUBAZIONI PIU' LUNGHE E/O CON PROTEZIONI SPECIALI.

COAXIAL FEEDING LINES

ALL LUBETOOLS ARE SUPPLIED WITH 5 M OF COAXIAL HOSES ALREADY ASSEMBLED IN THE BASE OF THE PNEUMATIC PUMPS. THE OUTSIDE NYLON HOSES HAVE A DIAMETER OF 6 MM AND THE INSIDE NYLON HOSES HAVE A DIAMETER OF 2.5 MM. THE INSIDE HOSES ARE 500 MM MORE LONGER THAN THE OUTSIDE HOSES BECAUSE HAVE TO BE JOIN TO THE NOZZLE, WHILE THE OUTSIDE HOSES HAVE TO BE JOIN TO THE STRAIGHT ADAPTORS. ON REQUEST IS POSSIBLE TO SUPPLY MORE LONGER HOSES AND/OR SPECIAL COVERING.

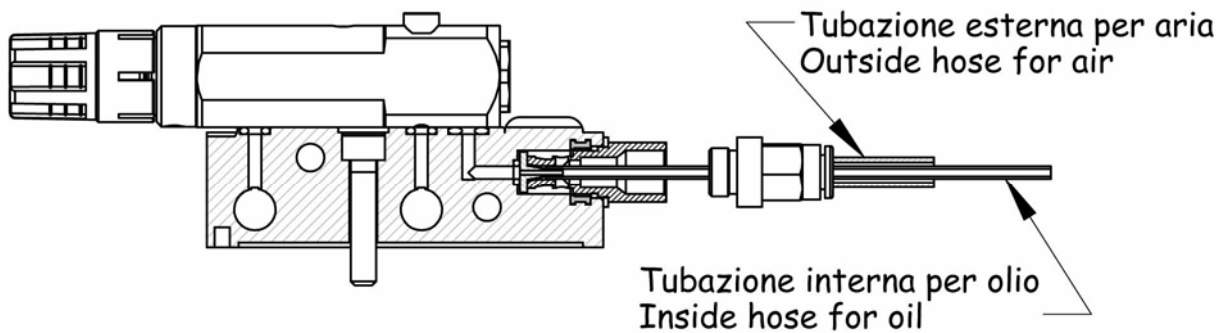

TERMINALI CON UGELLO

I TERMINALI CON UGELLO VENGONO FORNITI CON UNA LUNGHEZZA DI 300 MM E POSSONO ESSERE RIDOTTI TAGLIANDO UNA PARTE DELLA TUBAZIONE RIGIDA O ELIMINANDO PARTI DEL LOC-LINE

END TUBES WITH NOZZLE

THE END TUBES WITH NOZZLE HAVE AN OVERALL LENGTH OF 300 MM THAT CAN BE REDUCED CUTTING THE STEEL TUBE OR REMOVING PARTS OF THE LOC-LINE

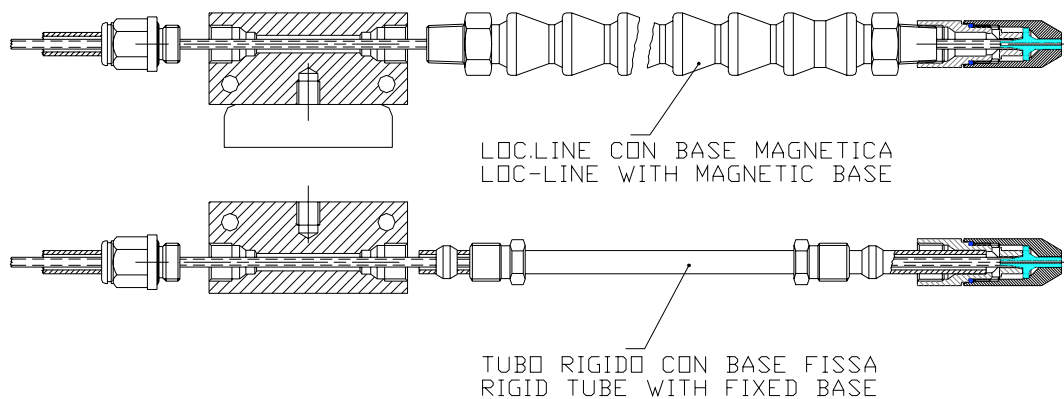

CODICI DI ORDINAZIONE – CODES FOR ORDER

CODICE CODE	TIPO	TYPE
70.100.0	LOC-LINE CON BASE FISSA (6 MM)	LOC-LINE WITH FIXED BASE (6 MM)
70.100.2	LOC-LINE CON BASE MAGNETICA (6 MM)	LOC-LINE WITH MAGNETIC BASE (6 MM)
70.100.1	TUBO RIGIDO CON BASE FISSA (6 MM)	RIGID TUBE WITH FIXED BASE (6 MM)
70.100.3	TUBO RIGIDO CON BASE MAGNETICA (6 MM)	RIGID TUBE WITH MAGNETIC BASE (6 MM)
70.101.0	LOC-LINE CON BASE FISSA (8 MM)	LOC-LINE WITH FIXED BASE (8 MM)
70.101.2	LOC-LINE CON BASE MAGNETICA (8 MM)	LOC-LINE WITH MAGNETIC BASE (8 MM)
70.101.1	TUBO RIGIDO CON BASE FISSA (8 MM)	RIGID TUBE WITH FIXED BASE (8 MM)
70.101.3	TUBO RIGIDO CON BASE MAGNETICA (8 MM)	RIGID TUBE WITH MAGNETIC BASE (8 MM)

IL CODICE INCLUDE L'UGELLO, IL TUBO RIGIDO O IL LOC-LINE E LA BASE FISSA O MAGNETICA

THE CODE INCLUDES THE NOZZLE, THE STEEL OR THE LOC-LINE TUBE AND THE MAGNETIC OR FIXED BASE.

UGELLI CON TESTA FILETTATA 1/8" GAS

NOZZLE WITH HEAD THREAD 1/8" GAS

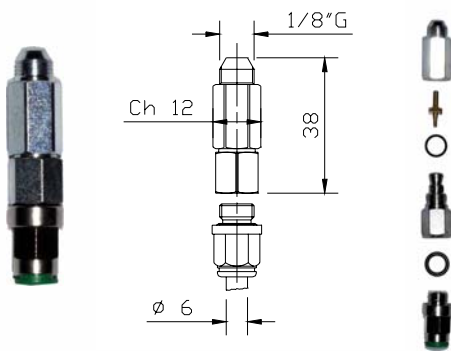

A70.093181

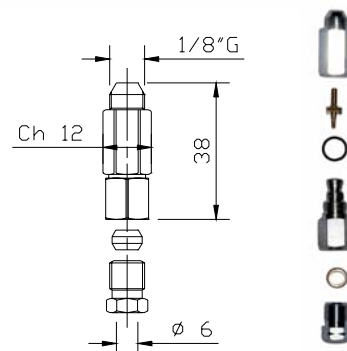

A70.093178

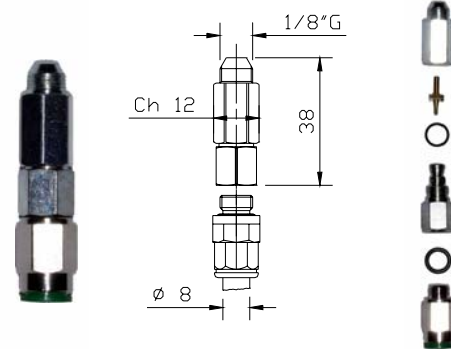

A70.093246

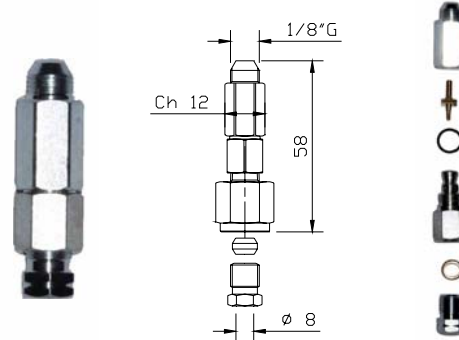

A70.093248



**TERMINALI CON UGELLO
DIMENSIONI D'INGOMBRO**

**END TUBES WITH NOZZLE
OVERALL DIMENSION**

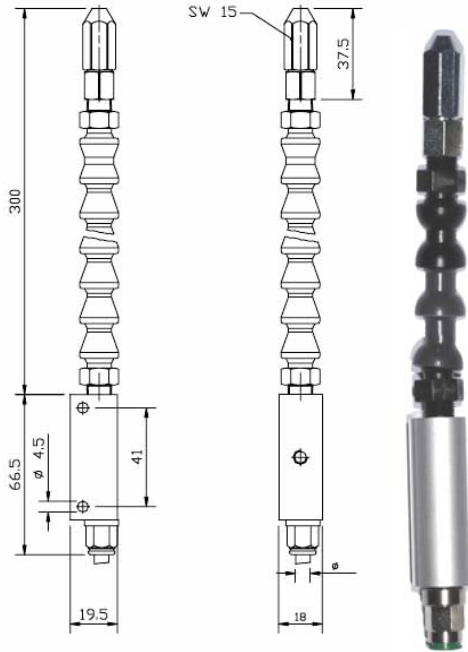

**70.100.0 (Ø6)
70.101.0 (Ø8)**

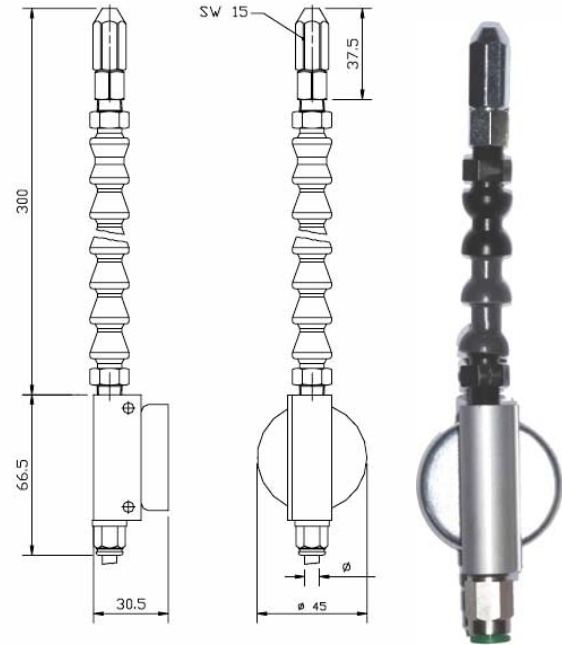

**70.100.2 (Ø6)
70.101.2 (Ø8)**

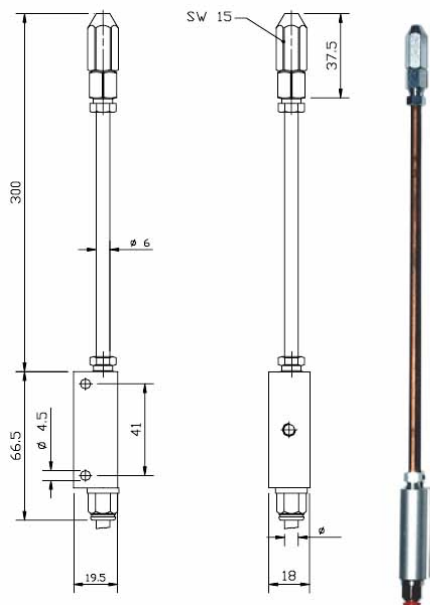

**70.100.1 (Ø6)
70.101.1 (Ø8)**

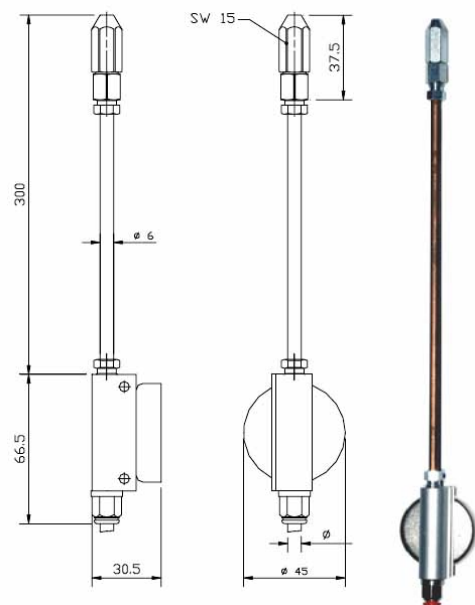

**70.100.3 (Ø6)
70.101.3 (Ø8)**



**TERMINALI CON UGELLO
DIMENSIONI D'INGOMBRO**
CODICE
70.103.8

**END TUBES WITH NOZZLE
OVERALL DIMENSION**
CODE
70.103.8

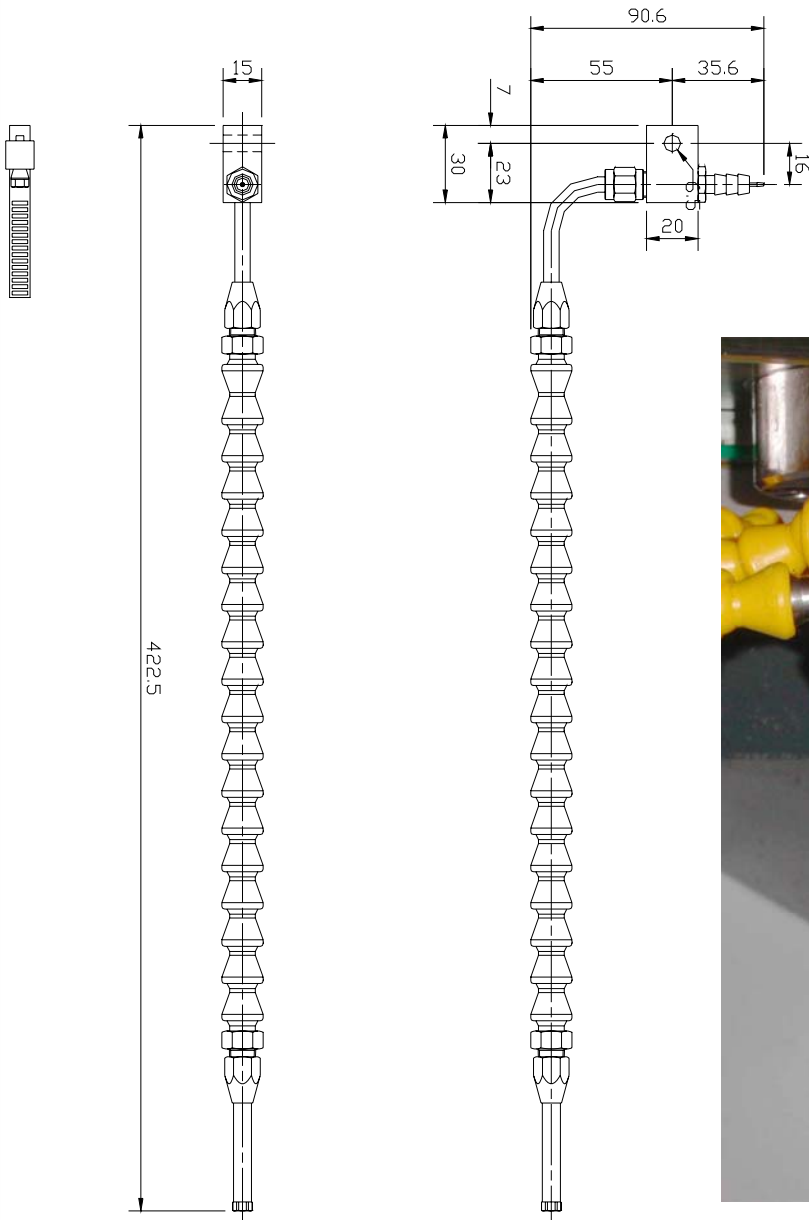

**TERMINALI CON UGELLO DECABON
DIMENSIONI D'INGOMBRO**

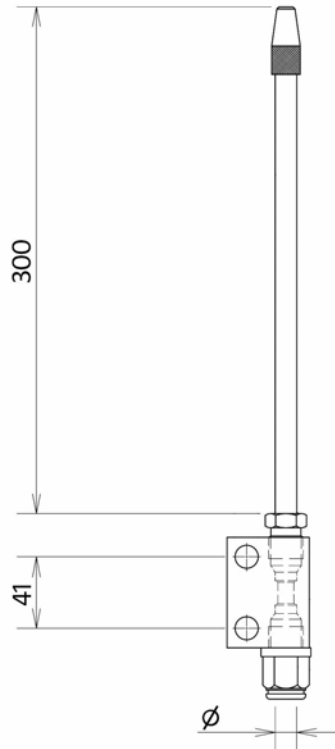

**END TUBES WITH DECABON NOZZLE
OVERALL DIMENSION**



CODICE CODE	UGELLO DECABON DECABON NOZZLE	Ø
70.118.2	CON BLOCCHETTO + RACCORDO RAPIDO / WITH BLOCK + PUSH-IN FITTING	6 MM
70.118.3	CON BLOCCHETTO MAGNETICO + RACCORDO RAPIDO / WITH MAGNETIC BLOCK + PUSH-IN FITTING	6 MM
70.118.4	CON BLOCCHETTO + RACCORDO RAPIDO / WITH BLOCK + PUSH-IN FITTING	8 MM
70.118.5	CON BLOCCHETTO MAGNETICO + RACCORDO RAPIDO / WITH MAGNETIC BLOCK + PUSH-IN FITTING	8 MM



UGELLI A SELLA PER SEGATRICI ORIZZONTALI
ALTEZZA LAMA: DA 6 MM A 34 MM
LUBRIFICANTE: OLIO

SADDLE NOZZLE FOR HORIZONTAL BAND SAW
BLADE HEIGHT: FROM 6 MM TO 34 MM
LUBRICANT: OIL

CODICE CODE	INGRESSI INLETS	USCITE OUTLETS
70.111.0	1	3

DIMENSIONI D'INGOMBRO

OVERALL DIMENSION

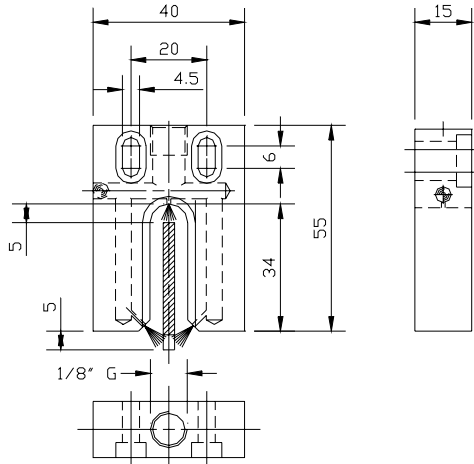

ALTEZZA LAMA: DA 41 MM A 80 MM
LUBRIFICANTE: OLIO

BLADE HEIGHT: FROM 41 MM TO 80 MM
LUBRICANT: OIL

CODICE CODE	INGRESSI INLETS	USCITE OUTLETS	LAMA BLADE	A	B	C
70.111.1	2	5	41	41	39	60
70.111.2	2	5	54	54	52	73
70.111.3	2	5	67	67	65	86
70.111.4	2	5	80	80	78	99

DIMENSIONI D'INGOMBRO

OVERALL DIMENSION

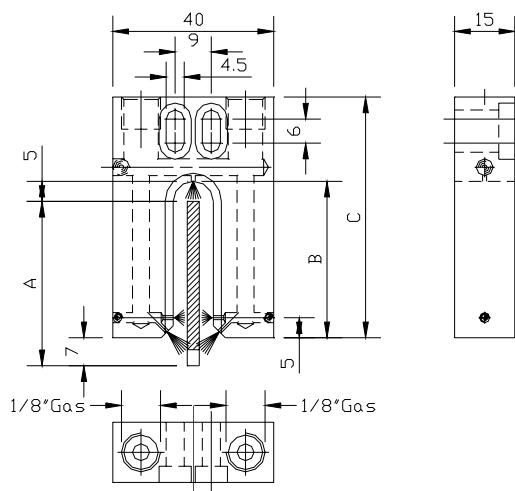

UGELLI A SELLA PER SEGATRICI VERTICALI
ALTEZZA LAMA: DA 6 MM A 34 MM
LUBRIFICANTE: OLIO

SADDLE NOZZLE FOR VERTICAL BAND SAW
BLADE HEIGHT: FROM 6 MM TO 34 MM
LUBRICANT: OIL

CODICE CODE	INGRESSI INLETS	USCITE OUTLETS
70.112.0	1	3

DIMENSIONI D'INGOMBRO OVERALL DIMENSION

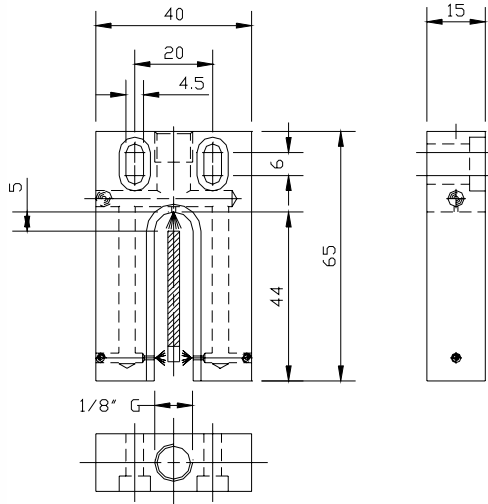

ALTEZZA LAMA: DA 41 MM A 80 MM
LUBRIFICANTE: OLIO

BLADE HEIGHT: FROM 41 MM TO 80 MM
LUBRICANT: OIL

CODICE CODE	INGRESSI INLETS	USCITE OUTLETS	LAMA BLADE	A	B	C
70.112.1	2	5	41	41	49	70
70.112.2	2	5	54	54	62	83
70.112.3	2	5	67	67	75	96
70.112.4	2	5	80	80	88	109

DIMENSIONI D'INGOMBRO OVERALL DIMENSION

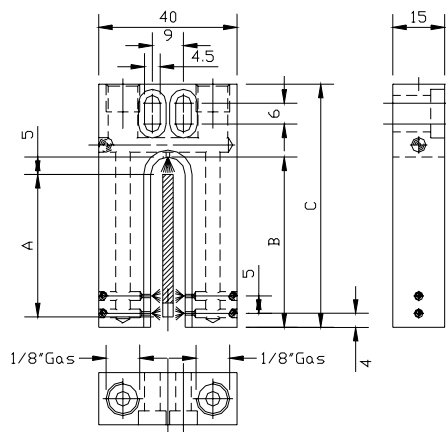

UGELLI A SELLA PER SEGATRICI ORIZZONTALI
ALTEZZA LAMA: DA 6 MM A 34 MM
LUBRIFICANTE: EMULSIONE

SADDLE NOZZLE FOR HORIZONTAL BAND SAW
BLADE HEIGHT: FROM 6 MM TO 34 MM
LUBRICANT: EMULSION

CODICE <i>CODE</i>	INGRESSI <i>INLETS</i>	USCITE <i>OUTLETS</i>
70.113.0	2	6

DIMENSIONI D'INGOMBRO

OVERALL DIMENSION

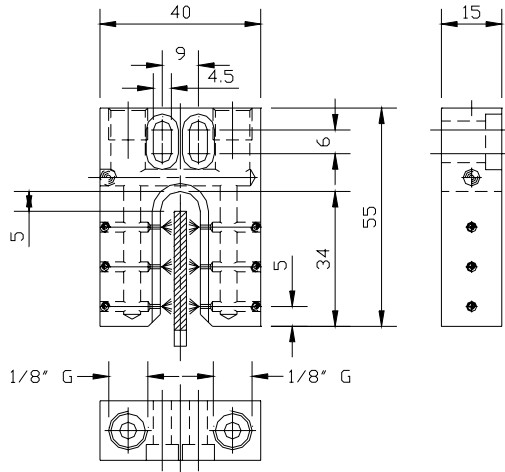

ALTEZZA LAMA: DA 41 MM A 80 MM
LUBRIFICANTE: EMULSIONE

BLADE HEIGHT: FROM 41 MM TO 80 MM
LUBRICANT: EMULSION

CODICE <i>CODE</i>	INGRESSI <i>INLETS</i>	USCITE <i>OUTLETS</i>	LAMA BLADE	A	B	C
70.113.1	2	6	41	41	39	60
70.113.2	2	8	54	54	52	73
70.113.3	2	10	67	67	65	86
70.113.4	2	12	80	80	78	99

DIMENSIONI D'INGOMBRO

OVERALL DIMENSION

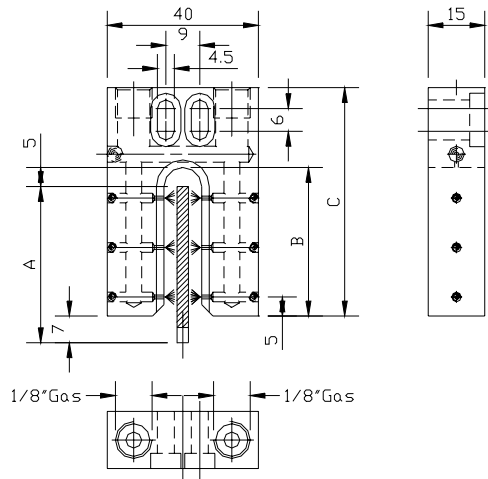

UGELLI A SELLA PER SEGATRICI VERTICALI
ALTEZZA LAMA: DA 6 MM A 34 MM
LUBRIFICANTE: EMULSIONE

SADDLE NOZZLE FOR VERTICAL BAND SAW
BLADE HEIGHT: FROM 6 MM TO 34 MM
LUBRICANT: EMULSION

CODICE <i>CODE</i>	INGRESSI <i>INLETS</i>	USCITE <i>OUTLETS</i>
70.114.0	2	6
DIMENSIONI D'INGOMBRO		OVERALL DIMENSION

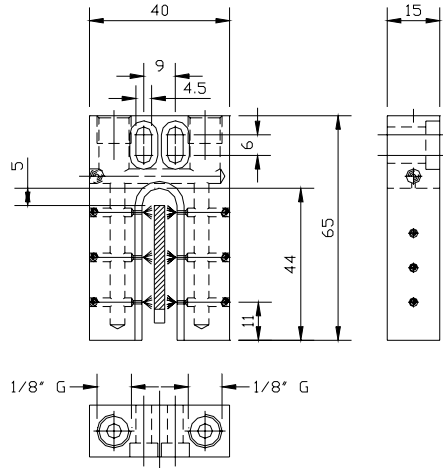

ALTEZZA LAMA: DA 41 MM A 80 MM
LUBRIFICANTE: EMULSIONE

BLADE HEIGHT: FROM 41 MM TO 80 MM
LUBRICANT: EMULSION

CODICE <i>CODE</i>	INGRESSI <i>INLETS</i>	USCITE <i>OUTLETS</i>	LAMA BLADE	A	B	C
70.114.1	2	6	41	41	49	70
70.114.2	2	8	54	54	62	83
70.114.3	2	10	67	67	75	96
70.114.4	2	12	80	80	88	109
DIMENSIONI D'INGOMBRO			OVERALL DIMENSION			

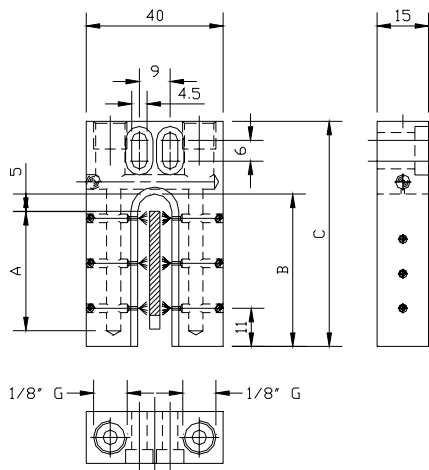

**UGELLI A SELLA PER SEGATRICI CIRCOLARI
LUBRIFICANTE: OLIO**

**SADDLE NOZZLE FOR CIRCULAR SAW
LUBRICANT: OIL**

CODICE CODE	INGRESSI INLETS	USCITE OUTLETS
70.106.2	2	5
DIMENSIONI D'INGOMBRO		OVERALL DIMENSION

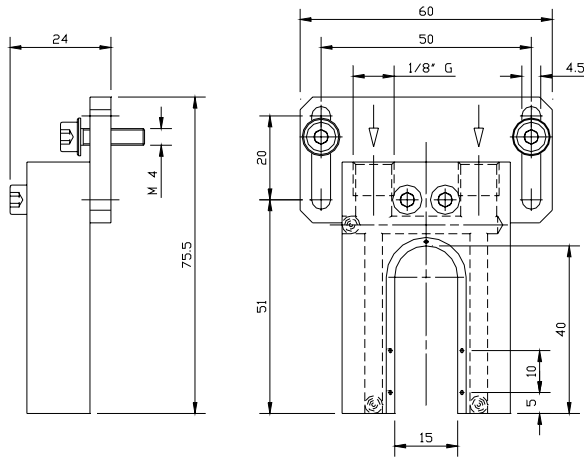

CODICE CODE	INGRESSI INLETS	USCITE OUTLETS	CODICE CODE	INGRESSI INLETS	USCITE OUTLETS
70.103.2	1	3	70.103.5	1	3
DIMENSIONI D'INGOMBRO			OVERALL DIMENSION		

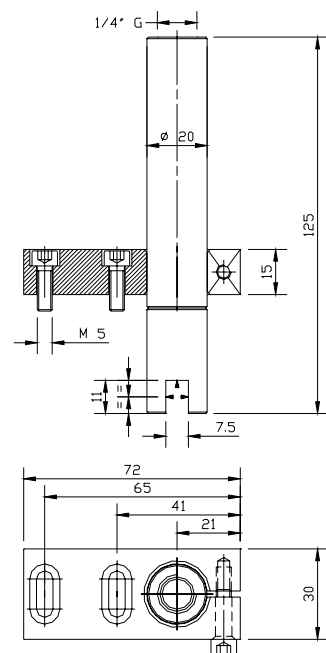
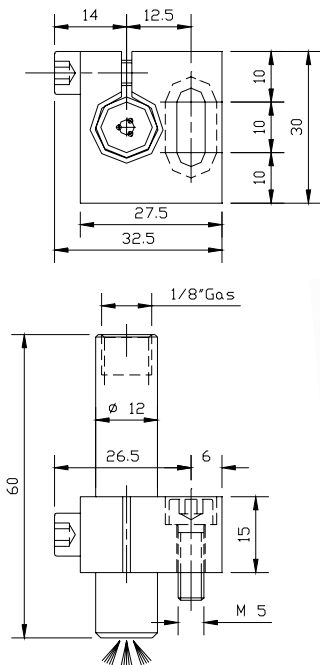

UGELLI PER SEGATRICI CIRCOLARI

LUBRIFICANTE: OLIO + EMULSIONE

NOZZLE FOR CIRCULAR SAW

LUBRICANT: OIL + EMULSION

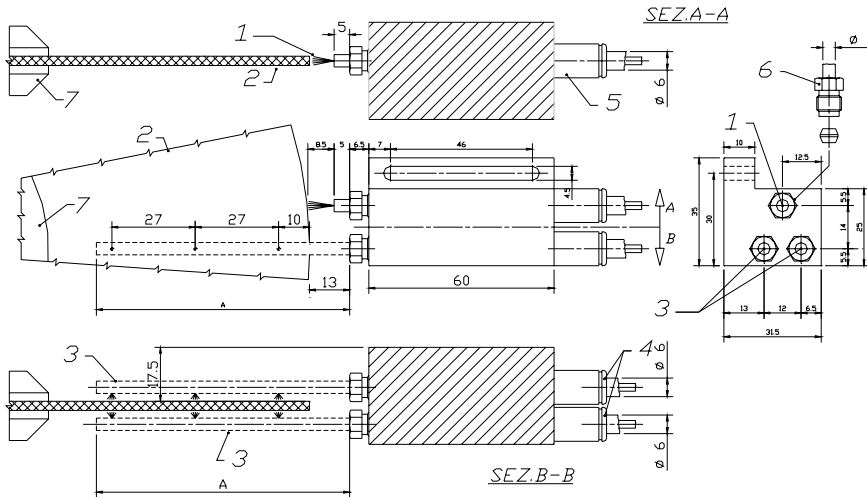

1	LUBRIFICAZIONE DENTE CON OLIO	TOOTH LUBRICATION WITH OIL
2	DISCO	DISK
3	LUBRIFICAZIONE FIANCHI CON EMULSIONE	SIDES LUBRICATION WITH EMULSION
4	RACCORDI RAPIDI TUBI 6 MM PER EMULSIONE	PUSH-IN FITTINGS TUBE 6 MM FOR EMULSION
5	RACCORDO RAPIDO TUBO 6 MM PER OLIO	PUSH-IN FITTING TUBE 6 MM FOR OIL
6	RACCORDO ED ANELLO PER TUBO 4 MM	NUT AND OLIVE FOR 4 MM TUBE
7	GHIERA DI FISSAGGIO DISCO	METAL RING TO FIX THE DISK

CODICI DI ORDINAZIONE

CODES FOR ORDER

CODICE CODE	FORI PER EMULSIONE EMULSION HOLES	DIAMETRO DISCO MM DISK DIAMETER MM	A
70.103.4.55	2 + 2	175 - 200	55
70.103.4.82	3 + 3	225 - 250 - 275	82
70.103.4.109	4 + 4	300 - 315 - 350 - 370 - 400	109



UGELLO SPECIALE PER SEGATRICI VERTICALI
DIMENSIONI D'INGOMBRO

CODICE
70.109.9

SPECIAL NOZZLE FOR VERTICAL BLADE
OVERALL DIMENSION

CODE
70.109.9

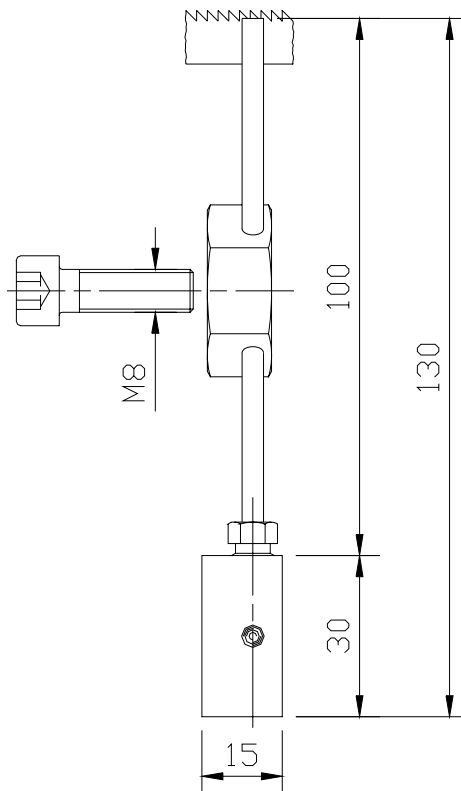
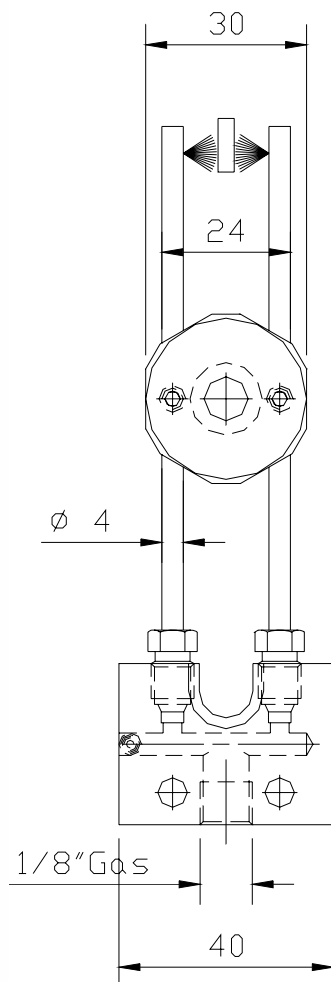

RACCORDI RAPIDI E TAPPI PER UGELLI A SELLA

PUSH-IN FITTINGS AND PLUG FOR SADDLE NOZZLE

A92.087058
1/8"

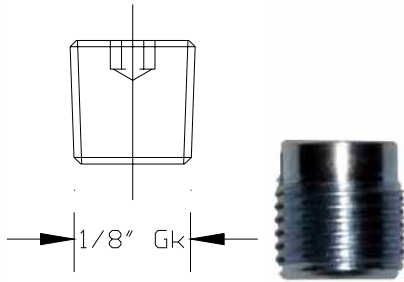

A92.106113
1/8" - 6 MM

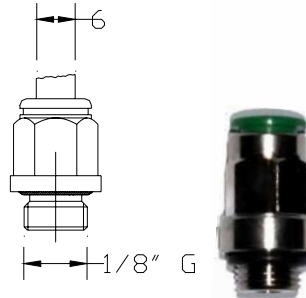

A92.106074
1/8" - 8 MM

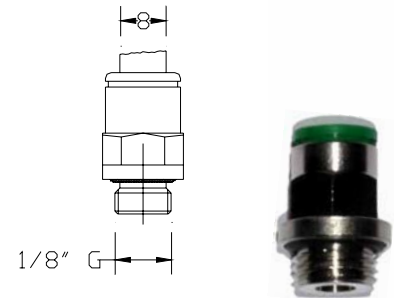

**PASSAPARETE CON RACCORDI RAPIDI PER TUBO COASSIALE
8x4 MM - 3x1.5 MM**

**BULKHEAD CONNECTION PUSH-IN FOR COAXIAL HOSES 8x4
MM - 3x1.5 MM**

A70.093230

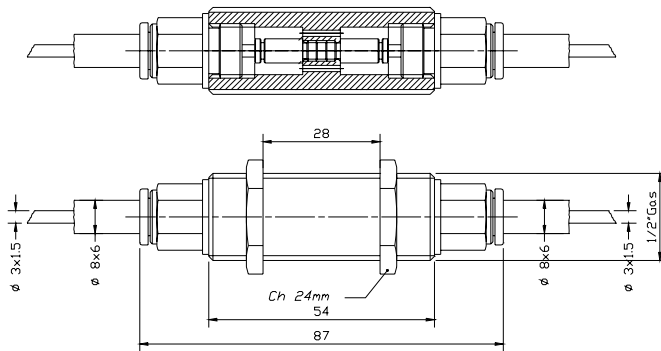

A70.093231

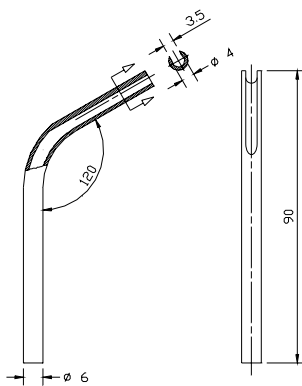

APPLICAZIONI

RICORDA CHE TROPPO OLIO NON AIUTA, USARE GOCCE NON LITRI

SEGATRICI A NASTRO
BAND SAW MACHINES

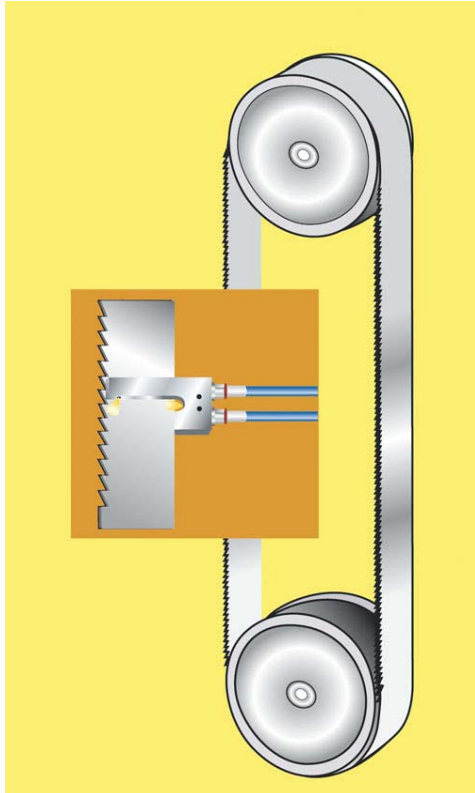

IL NUMERO DEGLI UGELLI DA UTILIZZARE DIPENDE DAI MATERIALI E DAL TIPO DI LAVORAZIONE

GUIDA PER LA SCELTA DEGLI UGELLI
SEGATRICI A NASTRO

LAMA DA 6 MM A 34 MM	1 INGRESSO – 3 USCITE	BLADE FROM 6 MM TO 34 MM	1 INLET – 3 OUTLETS
LAMA DA 41 MM A 80 MM	2 INGRESSI – 5 USCITE	BLADE FROM 41 MM TO 80 MM	2 INLETS – 5 OUTLETS

GUIDA PER LA SCELTA DEGLI UGELLI
SEGATRICI A DISCO

DISCO DA 175 MM A 225 MM	1 INGRESSO – 3 USCITE	DISK FROM 175 MM TO 225 MM	1 INLET – 3 OUTLETS
DISCO DA 250 MM A 400 MM	2 INGRESSI – 5 USCITE	DISK FROM 250 MM TO 400 MM	2 INLETS – 5 OUTLETS

APPLICATIONS

REMEMBER MORE IS NOT BETTER AND USE DROPS NOT LITRES

SEGATRICI CIRCOLARI
CIRCULAR SAW MACHINES



THE NUMBER OF NOZZLE TO USE IS DEPENDING ON THE MATERIALS AND THE ART OF PROCESSING

GUIDE TO SELECT THE NOZZLE
BAND SAW MACHINES

GUIDE TO SELECT THE NOZZLE
CIRCULAR SAW MACHINES



APPLICAZIONI

RICORDA CHE TROPPO OLIO NON AIUTA, USARE GOCCE NON LITRI

**MASCHIATURA
TAPPING**

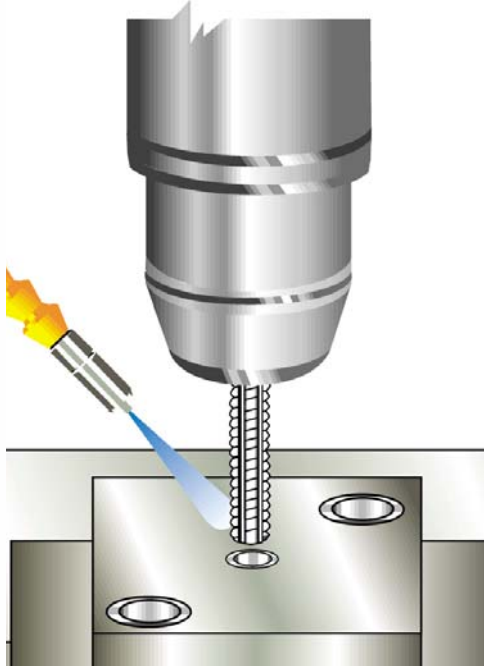

IL NUMERO DEGLI UGELLI DA UTILIZZARE DIPENDE DAI MATERIALI E DAL TIPO DI LAVORAZIONE

**GUIDA PER LA SCELTA DEGLI UGELLI
MASCHIATURA**

UTENSILE DA 3 MM A 10 MM	1 UGELLO	TOOL FROM 3 MM TO 10 MM	1 NOZZLE
UTENSILE DA 11 MM A 20 MM	2 UGELLI	TOOL FROM 11 MM TO 20 MM	2 NOZZLE
UTENSILE DA 21 MM A 40 MM	3 UGELLI	TOOL FROM 21 MM TO 40 MM	3 NOZZLE
UTENSILE DA 41 MM A 60 MM	4 UGELLI	TOOL FROM 41 MM TO 60 MM	4 NOZZLE

**GUIDA PER LA SCELTA DEGLI UGELLI
FORATURA - ALESATURA**

UTENSILE DA 1 MM A 12 MM	1 UGELLO	TOOL FROM 1 MM TO 12 MM	1 NOZZLE
UTENSILE DA 13 MM A 24 MM	2 UGELLI	TOOL FROM 13 MM TO 24 MM	2 NOZZLE
UTENSILE DA 25 MM A 48 MM	3 UGELLI	TOOL FROM 25 MM TO 48 MM	3 NOZZLE
UTENSILE DA 49 MM A 60 MM	4 UGELLI	TOOL FROM 49 MM TO 60 MM	4 NOZZLE

APPLICATIONS

REMEMBER MORE IS NOT BETTER AND USE DROPS NOT LITRES

**FORATURA - ALESATURA
DRILLING - BORING**



THE NUMBER OF NOZZLE TO USE IS DEPENDING ON THE MATERIALS AND THE ART OF PROCESSING

**GUIDE TO SELECT THE NOZZLE
TAPPING**

**GUIDE TO SELECT THE NOZZLE
DRILLING - BORING**



APPLICAZIONI

RICORDA CHE TROPPO OLIO NON AIUTA, USARE GOCCE NON LITRI

APPLICATIONS

REMEMBER MORE IS NOT BETTER AND USE DROPS NOT LITRES

FRESATURA – INCISIONE
MILLING - ENGRAVING

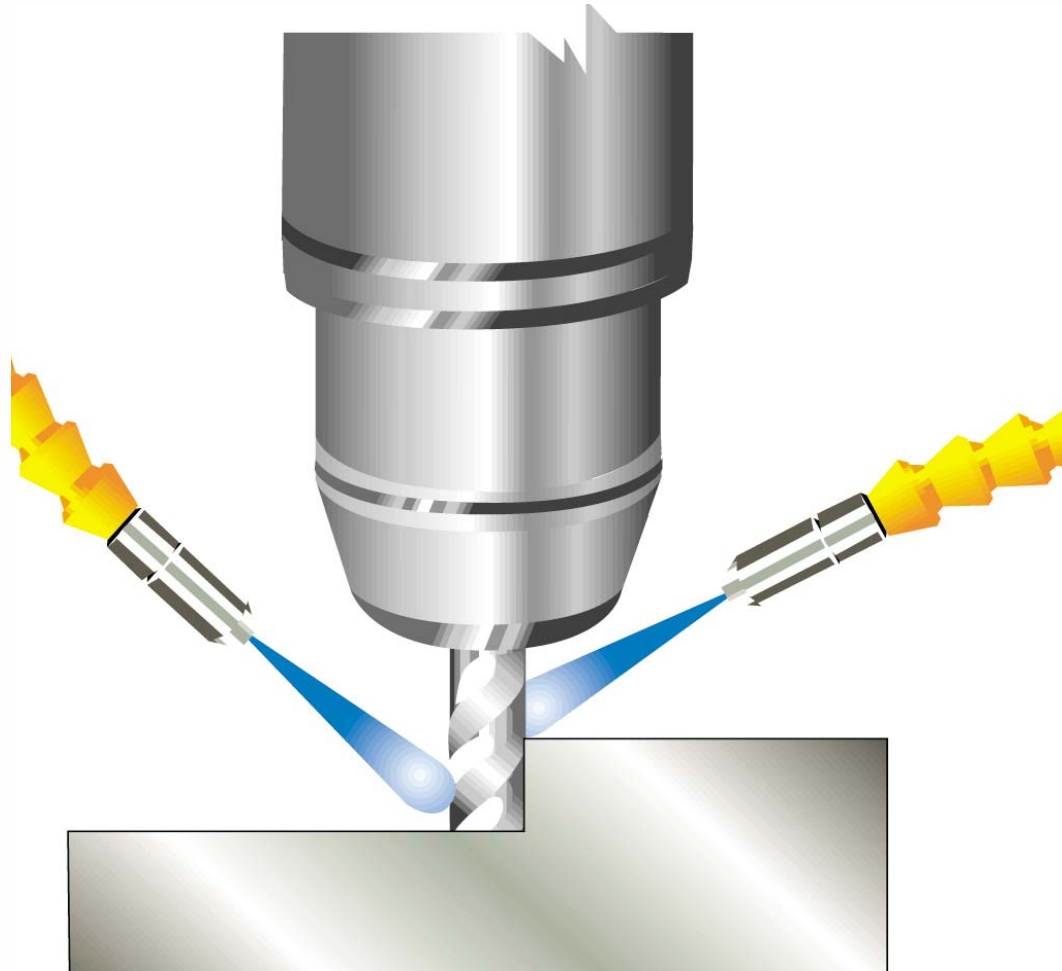

IL NUMERO DEGLI UGELLI DA UTILIZZARE DIPENDE DAI MATERIALI E DAL TIPO DI LAVORAZIONE

THE NUMBER OF NOZZLE TO USE IS DEPENDING ON THE MATERIALS AND THE ART OF PROCESSING

GUIDA PER LA SCELTA DEGLI UGELLI

GUIDE TO SELECT THE NOZZLE

UTENSILE DA 1 MM A 12 MM	1 UGELLO	TOOL FROM 1 MM TO 12 MM	1 NOZZLE
UTENSILE DA 13 MM A 40 MM	2 UGELLI	TOOL FROM 13 MM TO 40 MM	2 NOZZLE
UTENSILE DA 41 MM A 100 MM	3 UGELLI	TOOL FROM 41 MM TO 100 MM	3 NOZZLE
UTENSILE DA 101 MM A 240 MM	4 UGELLI	TOOL FROM 101 MM TO 240 MM	4 NOZZLE



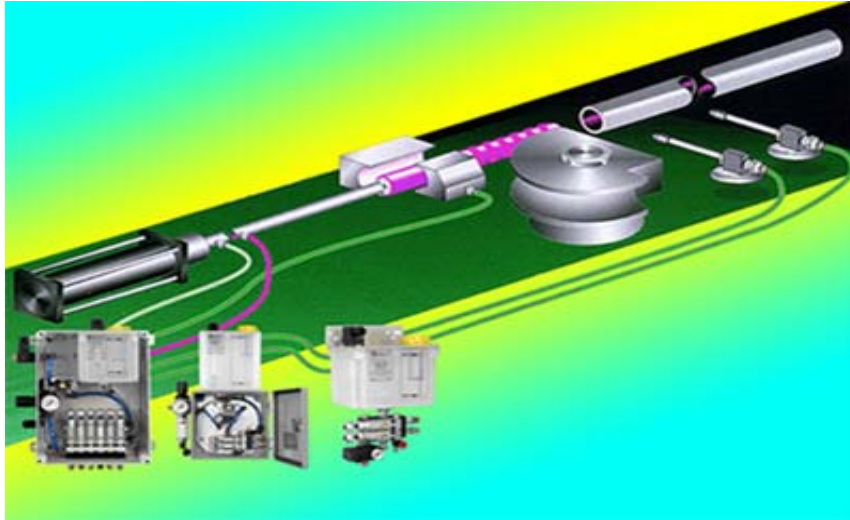

Il SISTEMA DI LUBRIFICAZIONE PER LA LAVORAZIONE DEI TUBI consiste di svariate opzioni, a seconda delle preferenze del cliente.

Normalmente il mandrino è lubrificato con una quantità di olio e una pressione dell'aria più alta rispetto agli altri punti. Lo spruzzo dispensato da ogni uscita è completamente regolabile. Il cliente può avere una combinazione di aria-olio o solo olio.

Possiamo configurare il sistema seguendo le esigenze del cliente.

Un'esatta quantità regolabile di lubrificante è mandata a tutti i punti che devono essere lubrificati. L'intero ambiente di lavoro rimane pulito.

BENEFICI:

La quantità di lubrificante che viene spruzzata è molto precisa

Ripetizione dei cicli in automatico

È possibile configurare il sistema automatizzandolo con la macchina

Varie combinazioni di uscite

Sistemi progettati e prodotti per soddisfare le richieste del cliente

Regolazione della quantità di aria ed olio per ogni punto di lubrificazione

The **TUBE FORMING LUBRICATION SYSTEM** consists of many options, it depends on customer preferences.

Normally the mandrel is lubricated with higher oil volume and higher air pressure than the other points. The spray dispensed to each outlet is fully adjustable. The customer can have an air-oil combination or just oil.

We can set the system following customers need.

An exact adjustable amount of lubricant is sent to all points that have to be lubricate. The whole working environment remains clean.

BENEFITS:

Positive lubricant injection

Automatic repeat cycling of lubricant metering pumps

Automatic cycling with machine

Various combination of outlets

Custom systems to meet customer's needs

Full adjustment of air and oil output at each lubrication point



APPLICAZIONI

RICORDA CHE TROPPO OLIO NON AIUTA, USARE GOCCE NON LITRI

LAVORAZIONE DEI TUBI

TAGLIO TRADIZIONALE
TAGLIO ORBITALE
TRANCIATURA
RASTREMATURA

APPLICATIONS

REMEMBER MORE IS NOT BETTER AND USE DROPS NOT LITRES

TUBE FABRICATION

TRADITIONAL CUTTING
ORBITAL CUTTING
SHEARING
TAGGING

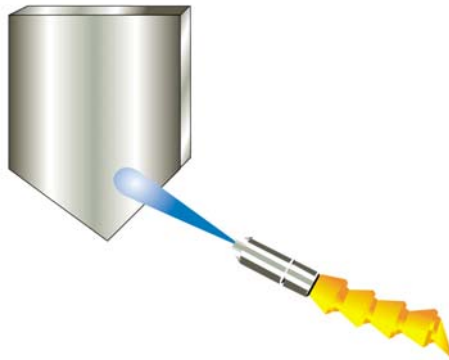

PUNZONATURA
FORATURA
INTESTATURA
SVASATURA

PUNCHING
DRILLING
FACING
FLARING

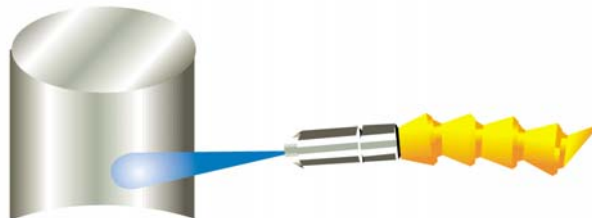

FORMATURA
PIEGATURA – CURVATURA
SAGOMATURA

FORMING
BENDING
SHAPING

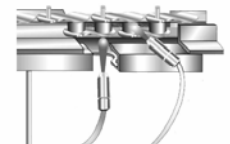
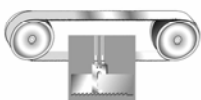
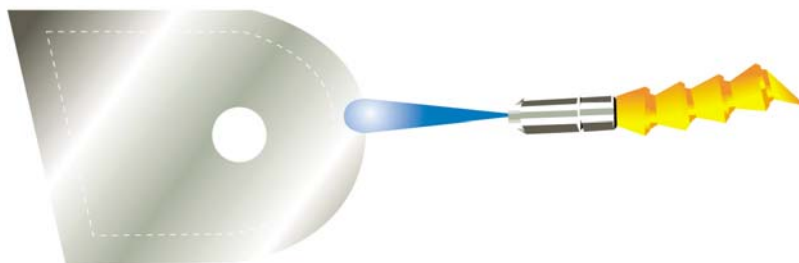

APPLICAZIONI

RICORDA CHE TROPPO OLIO NON AIUTA, USARE GOCCE NON LITRI

CATENARIE – CONVOGLIATORI AEREI MONO E BI-ROTAIA

GARANTISCONO UNA PERFETTA LUBRIFICAZIONE DEGLI ORGANI SOGGETTI AD USURA.

NON INQUINANO I PRODOTTI TRASPORTATI CON RESIDUI O GOCCIOLAMENTI DI OLIO.

NON PRODUCONO NEBBIE O VAPORI NOCIVI.

COMPATIBILI CON LE NUOVE GENERAZIONI DI LUBRIFICANTI DEFINITI "ANTIGOCCIA O AD ALTE DENSITA'" CHE GARANTISCONO UN PERFETTO ANCORAGGIO DEL PRODOTTO.

LA SCELTA DEL MODELLO DEVE AVVENIRE IN BASE AL NUMERO DELLE UTENZE DA LUBRIFICARE.

IL CONSENSO DI FUNZIONAMENTO E' INVIATO DA UN TASTATORE MECCANICO O DA UN SENSORE INDUTTIVO CHE, AZIONATO DAL PASSAGGIO DELLA CATENA, ECCITA UNA VALVOLA E/O UNA ELETTROVALVOLA PNEUMATICA. L'APERTURA DI QUEST' ULTIMA DETERMINA LA PARTENZA DEL SISTEMA CHE, DURANTE IL TEMPO DI LAVORO, PUO' INVIARE UN SINGOLO IMPULSO O PIU' IMPULSI IN BASE ALLA CONFIGURAZIONE DELL'UNITA'.

LA DURATA DEL TEMPO DI LAVORO E' DETERMINATA DAL TEMPO DI PASSAGGIO DEL TASTATORE SULLA CATENA.

L'UGELLO NORMALMENTE UTILIZZATO TERMINA NELLA CONFIGURAZIONE CON BLOCCHETTO E TUBO RIGIDO. QUESTA SOLUZIONE PERMETTE DI SAGOMARE ED INDIRIZZARE CON PRECISIONE IL GETTO FINALE SENZA L'AUSILIO DI ALTRE STRUTTURE DI SOSTEGNO.

IN ALCUNE OCCASIONI SONO IMPIEGATI GLI UGELLI CON PUNTA FILETTATA ED IN QUESTO CASO SONO NECESSARI DEI SUPPORTI DI SOSTEGNO CON FORO FILETTATO.

APPLICATIONS

REMEMBER MORE IS NOT BETTER AND USE DROPS NOT LITRES

CHAINS – MONO AND BI-RAIL CONVEYORS

THE LUBRICATION ASSURES MAXIMUM CHAIN LIFE AND OPTIMUM CONVEYOR OPERATION.

THE SYSTEM DOES NOT CONTAMINATE THE TRANSPORTED MATERIALS WITH OIL DROPS.

THE SYSTEM DO NOT PRODUCE FOG OR DANGEROUS VAPOUR.

LAST GENERATION OIL CAN BE USED WITHOUT PROBLEMS.

THE CORRECT UNIT DEPENDS ON THE NUMBER OF POINTS HAVE TO BE LUBRICATE.

THE UNIT WILL BEGIN TO OPERATE BY MEAN OF AN INDUCTIVE SENSOR OR A MECHANICAL FEELER PIN OPERATED FROM THE CHAIN.

A SOLENOID VALVE OR A VALVE WILL OPEN AND WILL SEND THE AIR TO THE SYSTEM.

DURING THE WORKING TIME WILL BE POSSIBLE TO HAVE ONE SHOT OR MORE SHOTS DEPENDING ON THE CHAIN HAVE TO BE LUBRICATED.

THE TIME THAT THE INDUCTIVE SENSOR OR THE MECHANICAL FEELER PIN IS ACTIVATED FROM THE CHAIN. WILL BE THE WORKING TIME.

THE MORE USED NOZZLE IS WITH STEEL UBE BECAUSE HAS THE POSSIBILITY TO BE ADJUSTED WITHOUT BRACKET.

SOME TIME ARE USED THE NOZZLE WITH A THREADED FINAL PART. IN THIS CASE HAS TO BE USED BRACKETS WITH THREAD HOLES.



SISTEMI DI LUBRIFICAZIONE PER CONVOGLIATORI

CONVEYORS LUBRICATION SYSTEMS

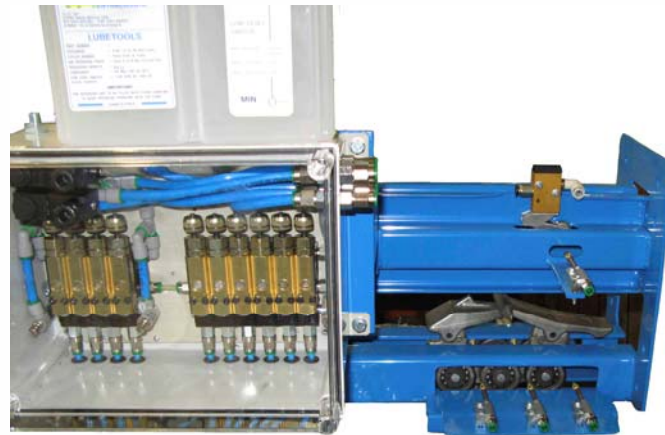

**SISTEMI DI LUBRIFICAZIONE PER
CONVOGLIATORI MONO E BI ROTAIA**

QUESTO SISTEMA È PROGETTATO PER LUBRIFICARE I RULLI DEI CONVOGLIATORI MENTRE SONO IN FUNZIONE E DISTRIBUISCE UNA QUANTITA' ESATTA DI LUBRIFICANTE NEI CUSCINETTI IN MOVIMENTO. QUESTI SISTEMI DI LUBRIFICAZIONE SONO PERFETTI PER APPLICAZIONI ANCHE IN CONDIZIONI DI LAVORO DIFFICILI. OGNI CONVOGLIATORE NECESSITA DI UNA UNITA' PER IL LATO SINISTRO E PER IL LATO DESTRO.

LA SEQUENZA DEGLI EVENTI DI LUBRIFICAZIONE (OGNI RULLO O OGNI RULLO SUPPLEMENTARE, ECC.) DIPENDE DAL NUMERO DI RULLI, DALLA VELOCITA' DEL NASTRO O DALLA DISTANZA TRA I RULLI.

BENEFICI

APPLICAZIONE DI UNA QUANTITA' ESATTA DI LUBRIFICANTE

LAVORA SU PARTI IN MOVIMENTO CHE RICHIEDONO MOLTO TEMPO PER LA LUBRIFICAZIONE MANUALE

LUBRIFICA MENTRE IL CONVOGLIATORE LAVORA – NESSUNA PERDITA NEI TEMPI DI PRODUZIONE

LUBRIFICA ANCHE IN CONDIZIONI DI LAVORO DIFFICILI

FUNZIONAMENTO

IL SISTEMA È FORMATO DA UN SERBATOIO CHE INVIA OLIO, PER GRAVITA', ALLE CAMERE DI DOSAGGIO DELLE MICROPOMPE PNEUMATICHE. L'ARIA NECESSARIA PER IL FUNZIONAMENTO DELLE POMPE E PER LO SPRUZZO DELL'OLIO VIENE INVIATA AL PASSAGGIO DEI CUSCINETTI CHE AZIONANO VALVOLE PNEUMATICHE A COMANDO MECCANICO O SENSORI INDUTTIVI, POSIZIONATI OPPORTUNAMENTE LUNGO I BINARI.

**CONVEYORS LUBRICATION
MONO AND BI RAIL SYSTEMS**

THIS SYSTEM IS DESIGNED TO LUBRICATE THE ROLLERS OF CONVEYORS WHILE THEY ARE IN OPERATION AND DELIVERS A METERED AMOUNT OF LUBRICANT INTO MOVING BEARING FITTINGS. THESE CUSTOM-ENGINEERED LUBRICATION SYSTEMS ARE PERFECT FOR APPLICATIONS EVEN IN HARSH OPERATING CONDITIONS.

EACH CONVEYOR REQUIRES ONE UNIT FOR THE LEFT SIDE AND FOR THE RIGHT.

THE SEQUENCE OF THE LUBRICATION EVENTS (EACH ROLLER OR EVERY OTHER ROLLER, ETC.) DEPENDS ON THE NUMBER OF ROLLERS, THE SPEED OF THE CONVEYOR OR ON THE DISTANCE BETWEEN THE ROLLERS.

BENEFITS

METERED APPLICATION OF LUBRICANT

WORKS ON MOVING PARTS WHICH CONSUMING TIME TO LUBRICATE MANUALLY

LUBRICATES WHILE THE CONVEYOR IS IN NORMAL OPERATION – NO LOST PRODUCTION TIME

LUBRICATION EVEN UNDER HARSH OPERATION CONDITION

FUNCTIONING

SYSTEM IS FORMED BY A RESERVOIR WHICH SENDS OIL, BY GRAVITY, TO THE DISPENSING ROOMS OF THE PNEUMATIC MICROPUMPS. NECESSARY AIR FOR THE FUNCTIONING OF THE PUMPS AND THE OIL SPRAY IS SENT ON THE PASSAGE OF BEARINGS THAT POWER PNEUMATIC VALVES WITH MECHANICAL CONTROL OR INDUCTIVE SENSORS, SUITABLY POSITIONED ALONG RAILROAD.



**SISTEMI DI LUBRIFICAZIONE PER
CONVOGLIATORI MONOROTAIA**

**CONVEYORS LUBRICATION
MONORAIL SYSTEMS**

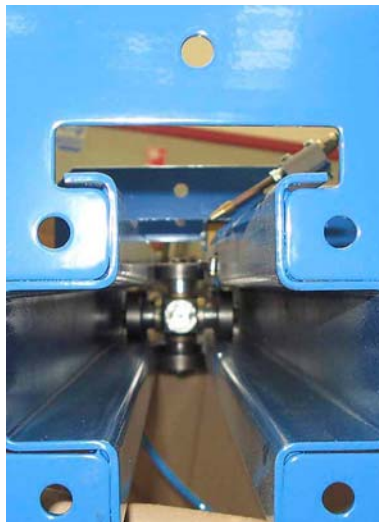

**SISTEMA TIPICO
CONVOGLIATORE MONOROTAIA**

**TYPICAL MONORAIL
CONVEYOR SYSTEM**

IL TIPICO SISTEMA PER CONVOGLIATORE MONOROTAIA È COMPOSTO DA

- 1) 2 VALVOLE PNEUMATICHE AD AZIONAMENTO MECCANICO O 2 SENSORI INDUTTIVI
- 2) 4 MICROPOMPE DIVISE IN DUE GRUPPI DA 2
- 3) UN SERBATOIO DA 2,2 L COMPLETO DI CONTROLLO DEL LIVELLO DI LUBRIFICANTE
- 4) 2 REGOLATORI DELL'ARIA DI SPRUZZO
- 5) 4 UGELLI

SIAMO COMUNQUE DISPONIBILI PER PROGETTARE SISTEMI SU SPECIFICA RICHIESTA DEL CLIENTE.

TYPICAL MONORAIL CONVEYOR SYSTEM IS COMPOSED BY:

- 1) 2 PNEUMATIC VALVES WITH MECHANICAL CONTROL OR 2 INDUCTIVE SENSORS
- 2) 4 MICROPUMPS DIVIDED IN TWO GROUPS OF 2
- 3) ONE 2.2 L RESERVOIR COMPLETE OF LUBRICANT LOW LEVEL SWITCH
- 4) 2 AIR REGULATORS
- 5) 4 NOZZLES

WE ARE STILL AVAILABLE FOR DESIGNING SYSTEMS ON SPECIFIC REQUEST OF CUSTOMER.



**SISTEMI DI LUBRIFICAZIONE PER
CONVOGIATORI BIROTAIA**

**CONVEYORS LUBRICATION
BIRAIL SYSTEMS**

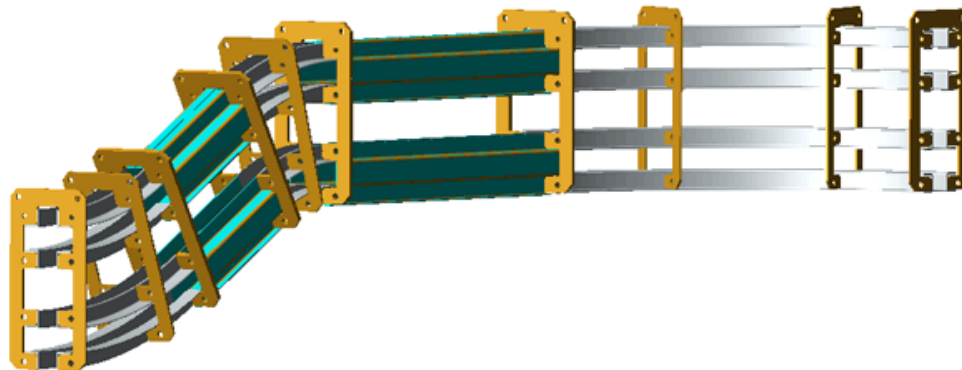

**SISTEMA TIPICO
CONVOGIATORE BIROTAIA**

**TYPICAL BIRAIL
CONVEYOR SYSTEM**

IL TIPICO SISTEMA PER CONVOGIATORE BIROTAIA È COMPOSTO DA:

TYPICAL BIRAIL CONVEYOR SYSTEM IS COMPOSED BY:

- 1) 3 O 4 VALVOLE PNEUMATICHE AD AZIONAMENTO MECCANICO O SENSORI INDUTTIVI
- 2) 10 O PIU' MICROPOMPE DIVISE IN DUE GRUPPI DA 2 ED UNO DA 6
- 3) UN SERBATOIO DA 3,6 L COMPLETO DI CONTROLLO DEL LIVELLO DI LUBRIFICANTE
- 4) 3 O PIU' REGOLATORI DELL'ARIA DI SPRUZZO
- 5) 10 O PIU' UGELLI

- 1) 3 OR 4 PNEUMATIC VALVES WITH MECHANICAL CONTROL OR INDUCTIVE SENSORS
- 2) 10 OR MORE MICROPUMPS DIVIDED INTO TWO GROUPS OF 2 AND ONE OF 6
- 3) ONE 3,6L RESERVOIR COMPLETE OF LOW LEVEL SWITCH
- 4) 3 OR MORE AIR REGULATOR
- 5) 10 OR MORE NOZZLES

SIAMO COMUNQUE DISPONIBILI PER PROGETTARE SISTEMI SU SPECIFICA RICHIESTA DEL CLIENTE.

WE ARE STILL AVAILABLE FOR DESIGNING SYSTEMS ON SPECIFIC REQUEST OF CUSTOMER.





APPLICAZIONI

RICORDA CHE TROPPO OLIO NON AIUTA, USARE GOCCE NON LITRI

CATENARIE – CONVOGLIATORI AEREI MONO E BI-ROTAIA

APPLICATIONS

REMEMBER MORE IS NOT BETTER AND USE DROPS NOT LITRES

CHAINS – MONO AND BI-RAIL CONVEYORS

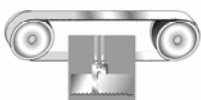
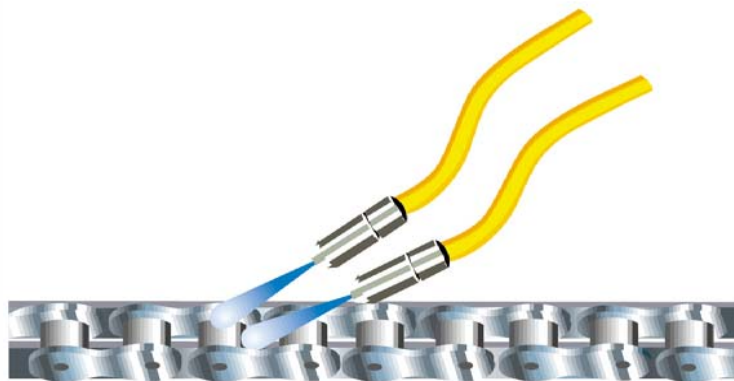
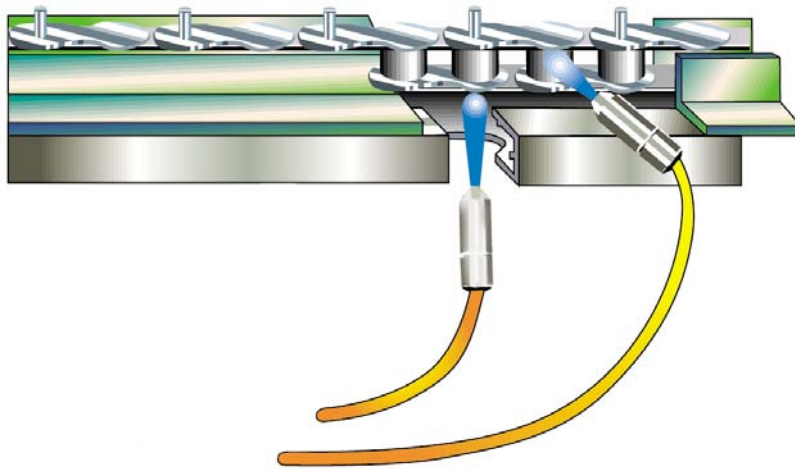

APPLICAZIONI

RICORDA CHE TROPPO OLIO NON AIUTA, USARE GOCCE NON LITRI

STAMPAGGIO E DEFORMAZIONE A FREDDO

LUBRIFICAZIONE DEL NASTRO E DEI PUNZONI

APPLICATIONS

REMEMBER MORE IS NOT BETTER AND USE DROPS NOT LITRES

METAL FORMING LUBRICATION

METAL FORMING LUBRICATION

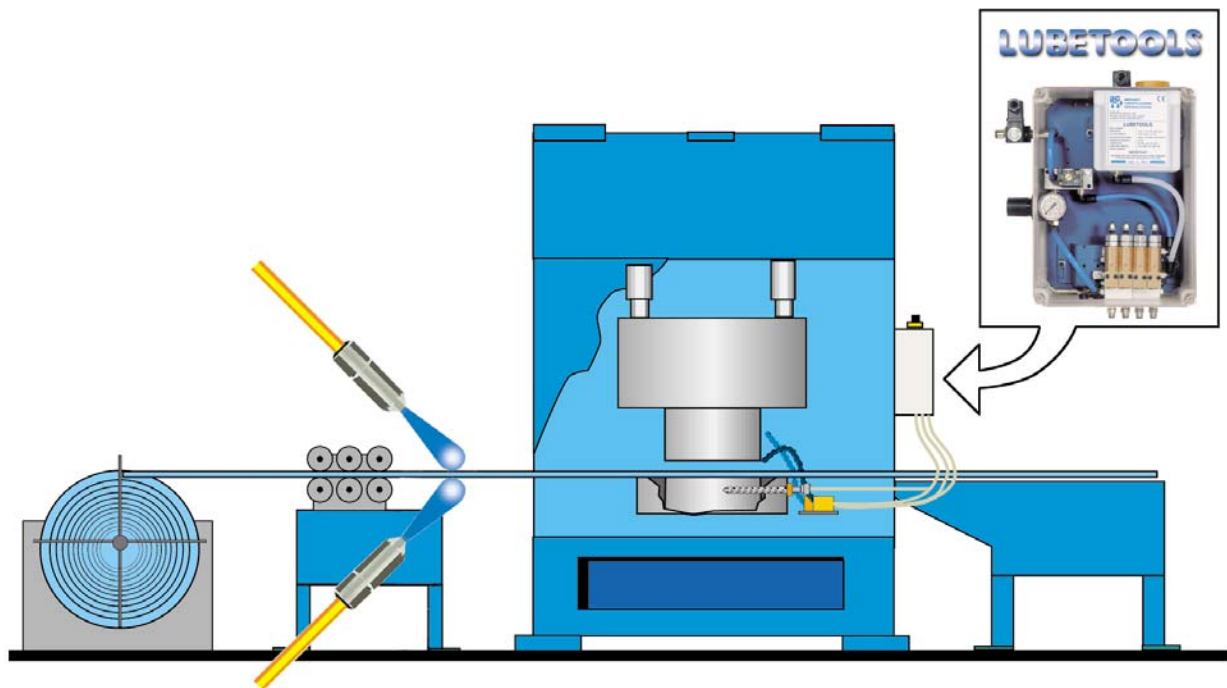

DISPOSIZIONE DEGLI UGELLI

POSITIONING NOZZLE

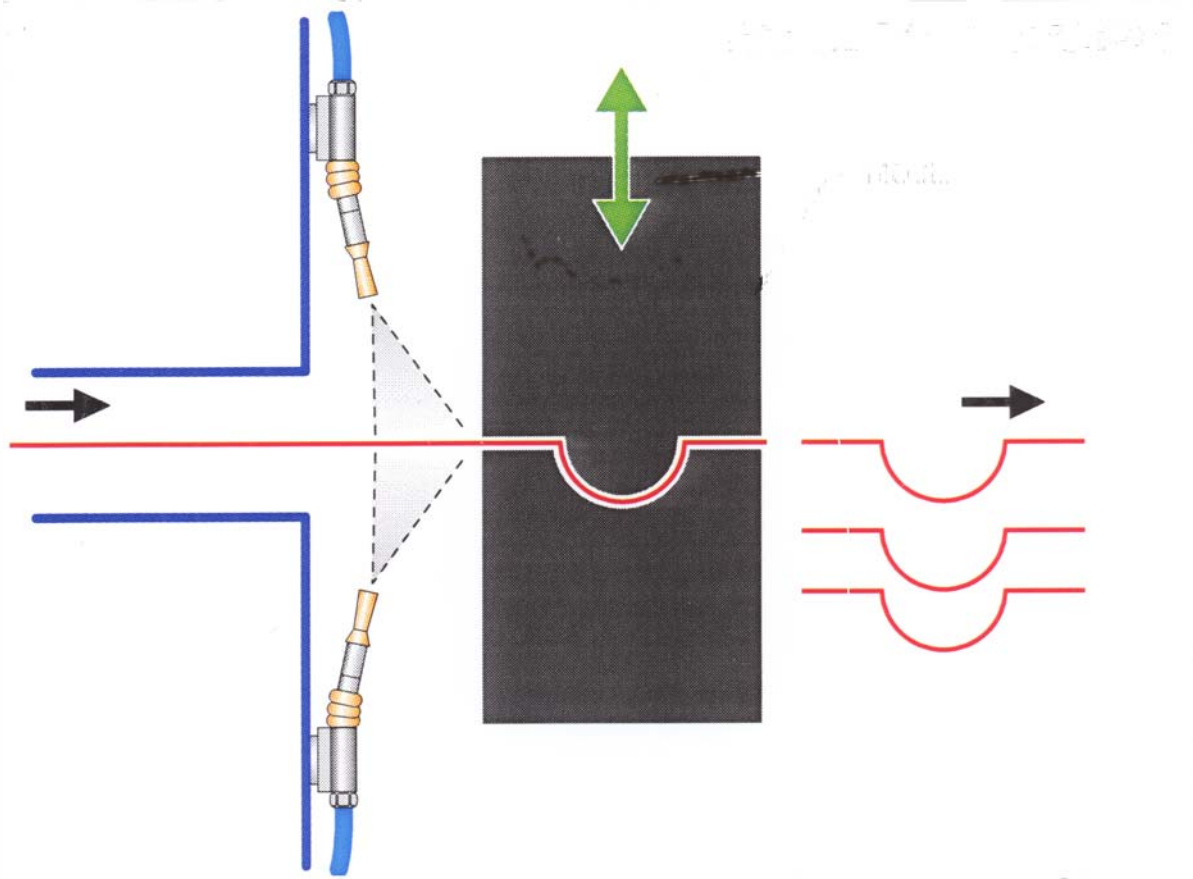

DISTANZA DAL FOGLIO 100-150 MM

DISTANZA DA UN ALTRO UGELLO 100 MM

ANGOLAZIONE 45 GRADI COME MOSTRATO IN FIGURA

OGNI UGELLO COPRE UNA SUPERFICIE DI 100-120 MM

SHEET DISTANCE 100-150 MM

DISTANCE FROM ANOTHER NOZZLE 100 MM

45° ANGLE AS SHOW ON THE PICTURE

EACH NOZZLE COVER A SURFACE OF 100-120 MM



**LUBRIFICAZIONE SOPRA E SOTTO DI UN NASTRO CON
LARGHEZZA DA 50 MM A 800 MM**

**STRIP TOP AND BOTTOM LUBRICATION WITH WIDTH FROM 50
MM TO 800 MM**

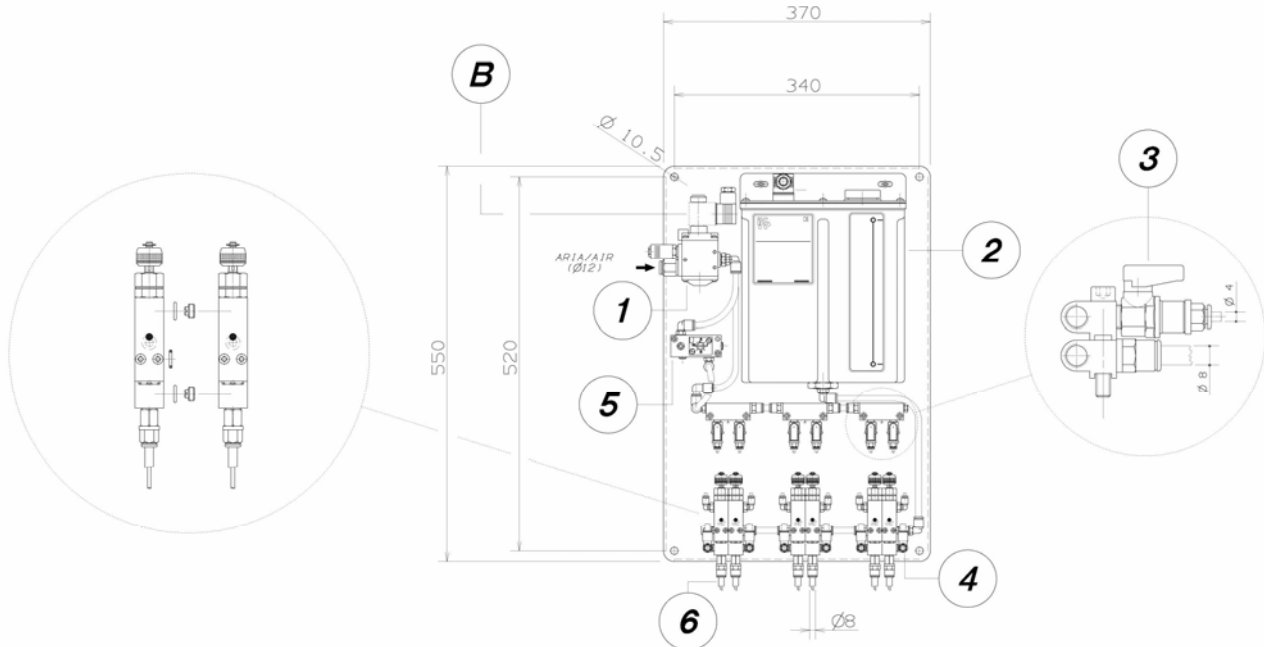

CODICE CODE	MANDATE WAYS
70.722.4	2
70.067.9	4
70.099.5	6

B	BOBINA	B	COIL
1	N. 2 ELETTROVALVOLE 24 V DC – 24 V AC – 115 V AC O 230 V AC LA PRIMA PER COMANDARE LE MICROPOMPE LA SECONDA PER INVIARE L'ARIA AGLI UGELLI	1	N. 2 SOLENOID VALVE 24 V DC – 24 V AC – 115 V AC OR 230 V AC FIRST TO DRIVE THE PUMPS/STROKES SECOND TO SEND AIR TO THE NOZZLE
2	SERBATOIO 6 L COMPLETO DI LIVELLO ELETTRICO 1 A 250 V AC 200 V DC 50 W	2	6 L RESERVOIR COMPLETE OF LOW LEVEL SWITCH 1 A 250 V AC 200 V DC 50 W
3	VALVOLA CHIUSURA/APERTURA ARIA POMPA	3	AIR PUMP ON/OFF VALVE
4	REGOLATORE ARIA PER UGELLO	4	NOZZLE AIR REGULATOR
5	GENERATORE DI FREQUENZA	5	FREQUENCY GENERATOR
6	5 M TUBO COASSIALE 8 MM	6	5 M COAXIAL TUBE 8 MM
I PUNTI SONO COMPLETAMENTE INDIPENDENTI E POSSONO ESSERE ESCLUSI CHIUDENDO LA VALVOLA 3 E IL CORRISPONDENTE REGOLATORE ARIA PER UGELLO. SONO DISPONIBILI SISTEMI PER LUBRIFICARE NASTRI CON LARGHEZZA INFERIORE E SUPERIORE		THE POINTS ARE INDEPENDENT AND CAN BE EXCLUDED CLOSING THE VALVE 3 AND THE CORRESPONDENT NOZZLE AIR REGULATOR. ON REQUEST IT IS POSSIBLE TO SUPPLY UNITS TO LUBRICATE STRIP WITH LOWER OR UPPER WIDTH.	

CODICI PER ORDINARE BOBINE DELL'ELETTROVALVOLA 14.662.5 – CODES TO ORDER SOLENOID VALVE 14.662.5 COILS

14.662.1.R	14.662.2.R	14.662.3.R	14.662.4.R
24 V DC	115 V AC	230 V AC	24 V AC



**LUBRIFICAZIONE SOPRA E SOTTO DI UN NASTRO CON
LARGHEZZA DA 50 MM A 800 MM**

**STRIP TOP AND BOTTOM LUBRICATION WITH WIDTH FROM 50
MM TO 800 MM**

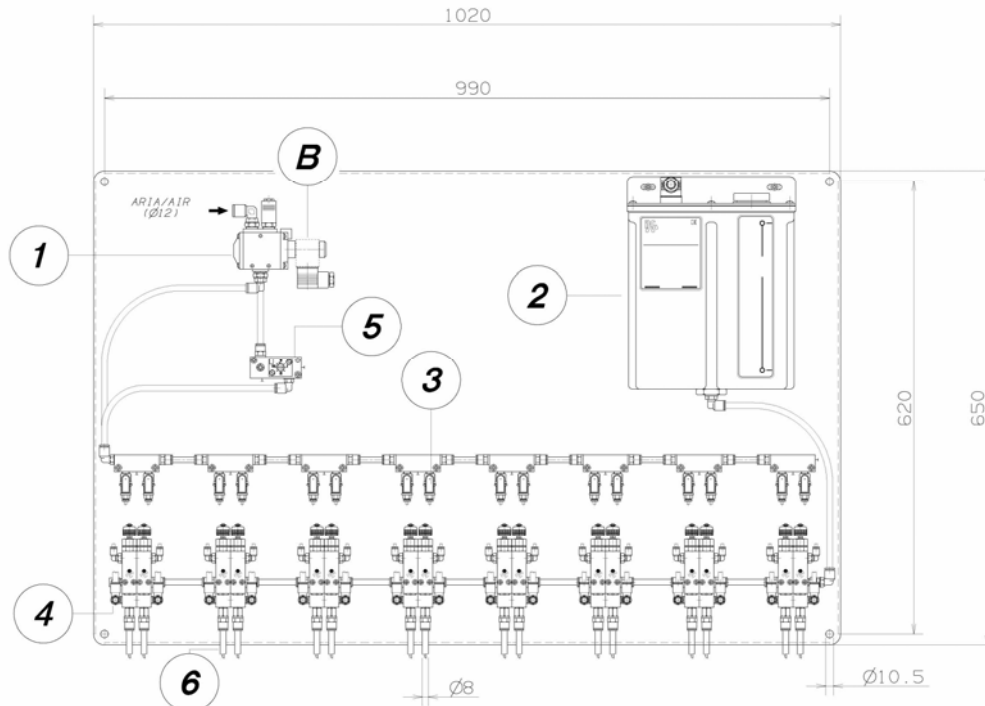

CODICE CODE	MANDATE WAYS
70.712.1	8
70.071.4	10
70.722.1	12
70.723.8	14
70.073.4	16

B	BOBINA	B	COIL
1	N. 2 ELETTROVALVOLE 24 V DC – 24 V AC – 115 V AC O 230 V AC LA PRIMA PER COMANDARE LE MICROPOMPE LA SECONDA PER INVIARE L'ARIA AGLI UGELLI	1	N. 2 SOLENOID VALVE 24 V DC – 24 V AC – 115 V AC OR 230 V AC FIRST TO DRIVE THE PUMPS/STROKES SECOND TO SEND AIR TO THE NOZZLE
2	SERBATOIO 6 L COMPLETO DI LIVELLO ELETTRICO 1 A 250 V AC 200 V DC 50 W	2	6 L RESERVOIR COMPLETE OF LOW LEVEL SWITCH 1 A 250 V AC 200 V DC 50 W
3	VALVOLA CHIUSURA/APERTURA ARIA POMPA	3	AIR PUMP ON/OFF VALVE
4	REGOLATORE ARIA PER UGELLO	4	NOZZLE AIR REGULATOR
5	GENERATORE DI FREQUENZA	5	FREQUENCY GENERATOR
6	5 M TUBO COASSIALE 8 MM	6	5 M COAXIAL TUBE 8 MM
I PUNTI SONO COMPLETAMENTE INDIPENDENTI E POSSONO ESSERE ESCLUSI CHIUDENDO LA VALVOLA 3 E IL CORRISPONDENTE REGOLATORE ARIA PER UGELLO. SONO DISPONIBILI SISTEMI PER LUBRIFICARE NASTRI CON LARGHEZZA INFERIORE E SUPERIORE		THE POINTS ARE INDEPENDENT AND CAN BE EXCLUDED CLOSING THE VALVE 3 AND THE CORRESPONDENT NOZZLE AIR REGULATOR. ON REQUEST IT IS POSSIBLE TO SUPPLY UNITS TO LUBRICATE STRIP WITH LOWER OR UPPER WIDTH.	

CODICI PER ORDINARE BOBINE DELL'ELETTROVALVOLA 14.662.5 – CODES TO ORDER SOLENOID VALVE 14.662.5 COILS

14.662.1.R	14.662.2.R	14.662.3.R	14.662.4.R
24 V DC	115 V AC	230 V AC	24 V AC

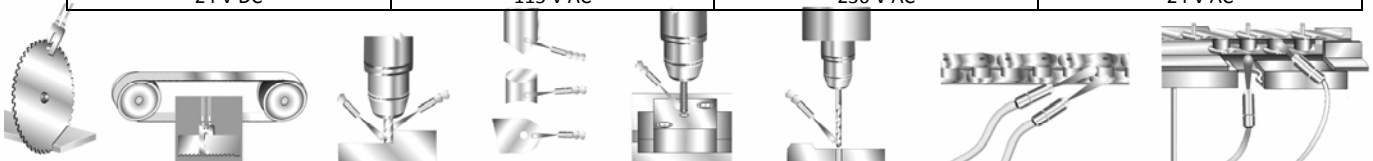

**UGELLI DI PROIEZIONE CON GETTO PIATTO
PER AVANZAMENTO LENTO**

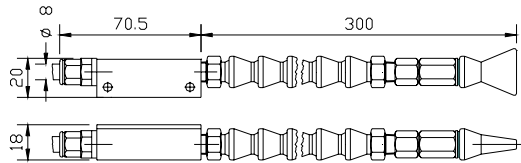

70.102.0

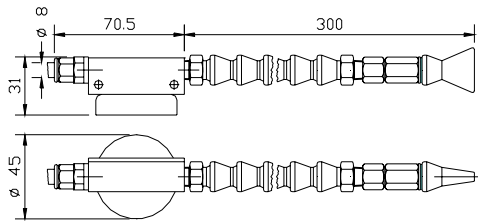

70.102.1

**FLAT NOZZLE
FOR SLOW FEED**

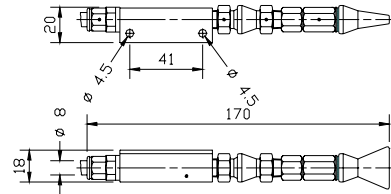

70.102.4

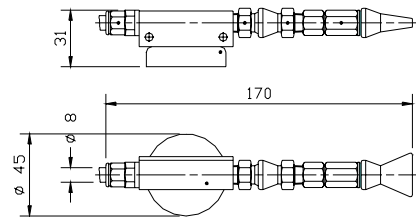

70.102.5

CODICE - CODE	DESCRIZIONE	DESCRIPTION
70.102.0	LOC-LINE CON BASE FISSA	LOC-LINE WITH FIXED BASE
70.102.1	LOC LINE CON BASE MAGNETICA	LOC-LINE WITH MAGNETIC BASE
70.102.4	BASE FISSA	FIXED BASE
70.102.5	BASE MAGNETICA	MAGNETIC BASE



OLIO VEGETALE NATURAL – 77

LUBRIFICANTI INTEGRALI DI ORIGINE NATURALE

IL DIPARTIMENTO TECNICO ILC HA MESSO A PUNTO UNA SERIE DI LUBROREFRIGERANTI INTEGRALI DI ORIGINE NATURALE DENOMINATI NATURAL SERIE 77, CON IL PRECISO SCOPO DI MIGLIORARE DRASTICAMENTE LE CONDIZIONI AMBIENTALI DI LAVORO E NEL CONTEMPO FORNIRE RENDIMENTI DEGLI UTENSILI DA TAGLIO SUPERIORI A QUELLI OTTENIBILI CON L'UTILIZZO DEI TRADIZIONALI OLI DA TAGLIO MINERALI INTEGRALI. LA SERIE NATURAL 77 È COMPLETAMENTE ESENTE DA QUALSIASI OLIO MINERALE LUBRIFICANTE ED È COMPOSTA PER LA SUA TOTALITÀ DA ESTERI SINTETICI DERIVATI DA MATERIE PRIME DI ORIGINE NATURALE. INODORI, DI COLORE CHIARO, I PRODOTTI SONO COMPLETAMENTE BIODEGRADABILI ED ASSOLUTAMENTE NON NOCIVI; L'USO DELLA SERIE NATURAL 77 TOGLIE COMPLETAMENTE LA CAUSA DI RISCHIO RELATIVA ALL'USO DI OLI MINERALI E DI CONSEGUENZA LE VISITE MEDICHE PERIODICHE OBBLIGATORIE.

LA SERIE NATURAL 77 HA INOLTRE UN OTTIMO POTERE LUBRIFICANTE UNITO A PREROGATIVE DI ESTREMA PRESSIONE ED UNA BUONA AZIONE RAFFREDDANTE CHE LA RENDE IDONEA AD OTTENERE I MASSIMI RISULTATI CON FORTI AVANZAMENTI E CON IL TIPO DI UTENSILE IN USO, EVITANDO BRUCIATURE E GRIPPAGGI.

LA SERIE NATURAL 77 HA ANCHE LA PREROGATIVA DI RIDURRE I FUMI A MANIFESTAZIONI NON SIGNIFICATIVE, HA UNA BASSA VOLATILITÀ CHE RIDUCE NOTEVOLMENTE I CALI PER IL VAPORE, UNA NOTEVOLE STABILITÀ CHIMICA TALE DA EVITARE POLIMERIZZAZIONE O DEGRADAZIONE DEL PRODOTTO IN UTILIZZO; PER ULTIMO MA NON MENO IMPORTANTE, IL NATURAL 77 HA LA CARATTERISTICA DI AUTOSPEGNERSI ISTANTANEAMENTE ALL'INSORGERE DI UN INNESCO DI INCENDIO.

NATURAL 77 È UN FLUIDO INTEGRALE A COMPLESSA ADDITIVAZIONE, CON ELEVATO POTERE ANTISALDANTE E SPICCATO RESISTENZA ALLE ESTREME PRESSIONI CHE, UTILIZZATO UNITAMENTE AD UTENSILI O INSERTI IN METALLO CERAMICO, PERMETTE DI RADDOPPIARE LA VELOCITÀ DI AVANZAMENTO RISPETTO AI PARAMETRI ABITUALI DI UTILIZZO. L'USO DEL NATURAL 77 ELIMINA I FUMI IMPONENTI CHE SI FORMEREBBERO CON OLI TRADIZIONALI ALL'INCREMENTO DELLE VELOCITÀ DI AVANZAMENTO SOPRA INDICATE. IL NATURAL 77 È IDONEO INOLTRE PER ESSERE UTILIZZATO SU MACCHINE DENTATRICI CHE UTILIZZANO SIA SISTEMI DI TAGLIO TIPO "GLEASON", SIA STOZZE TIPO "FELLOWS". IL NATURAL 77 È INOLTRE COMPLETAMENTE PRIVO DI CLORO E SUOI DERIVATI.

VEGETABLE OIL NATURAL – 77

INTEGRAL LUBRICANT OF NATURAL ORIGINS

ILC TECHNICAL DEPARTMENT HAS SET A SERIES OF LUBRICANT/COOLANT OF NATURAL ORIGINS CALLED NATURAL 77 SERIES, WITH THE PRECISE AIM OF IMPROVING DRAMATICALLY THE WORKING ENVIRONMENT CONDITIONS AND IN THE MEANWHILE TO SUPPLY CUTTING TOOLS PERFORMANCES HIGHER TO THAT ACHIEVABLE WITH THE USE OF TRADITIONAL CUTTING NEAT MINERAL OILS. NATURAL 77 SERIES IS WHOLLY FREE FROM ANY LUBRICANT MINERAL OIL AND IT IS COMPOSED TOTALLY BY SYNTHETIC ESTERS DERIVED FROM RAW MATERIALS OF NATURAL ORIGINS. ODOURLESS, LIGHT-COLOURED, THESE PRODUCTS ARE WHOLLY BIODEGRADABLE AND ABSOLUTELY NON-TOXIC, THE USE OF NATURAL 77 SERIES AVOIDS TOTALLY THE RISK DUE TO THE USE OF MINERAL OILS AND CONSEQUENTLY THE PERIODICAL MEDICAL VISIT.

IN ADDITION, NATURAL 77 SERIES HAS AN EXCEPTIONAL LUBRICANT POWER COMBINED WITH EXTREME PRESSURE PREROGATIVES AND A GOOD COOLING ACTION WHICH KEEPS IT SUITABLE TO OBTAIN MAXIMAL RESULTS WITH STRONG FEEDS AND WITH THE TYPE OF WORKING TOOL, AVOIDING GASSINGS AND SEIZING-UP.

NATURAL 77 SERIES HAS EVEN THE PREROGATIVE TO REDUCE SMOKES, HAS LOW VOLATILITY WHICH REDUCES NOTEWORTHY STEAM REDUCTION, SUCH AN EXCELLENT CHEMICAL STABILITY TO AVOID POLYMERISATION OR DEGRADATION OF THE USING PRODUCT; LAST, BUT NOT THE LEAST, NATURAL 77 HAS THE CHARACTERISTIC OF AUTO EXTINGUISHING IMMEDIATELY AT THE ARISING OF A FIRE TRIGGER.

NATURAL 77 IS A NEAT FLUID WITH COMPLEX ADDITIVATION, WITH VERY HIGH ANTI-WELDING POWER AND CONSPICUOUS EXTREME PRESSURE RESISTANCE, AND, USED WITH TOOLS OR CERAMIC METAL INSERTS, IT ALLOWS TO DOUBLE THE FEED SPEED IN COMPARISON WITH THE USUAL PARAMETERS OF USAGE. THE USE OF NATURAL 77 AVOIDS SMOKES THAT WOULD DEVELOP WITH TRADITIONAL OILS DURING THE INCREASING FEED SPEEDS MENTIONED ABOVE. FURTHERMORE, NATURAL 77 IS SUITABLE TO BE USED ON GEAR-CUTTING MACHINES USING BOTH CUTTING SYSTEMS SUCH AS "GLEASON" AND SLOTTING MACHINE SUCH AS "FELLOWS". NATURAL 77 IS ALSO WHOLLY FREE OF CHLORINE AND ITS DERIVATIVES.

PRODOTTO PRODUCT	PESO SPECIFICO A 15 °C KG/L SPECIFIC GRAVITY AT 15 °C KG/L	VISCOSITA' cSt A 40 °C VISCOSITY cSt A 40 °C	PUNTO D'INFIAMMABILITA' °C FLASH POINT °C
NATURAL 77	0.928	68	290
CODICE / CODE	DESCRIZIONE / DESCRIPTION		Q.TA' / Q.TY
30.600.6	5 L OLIO VEGETALE NATURAL 77 / 5 L VEGETABLE OIL NATURAL 77		1



**COMPONENTI
SERBATOI**

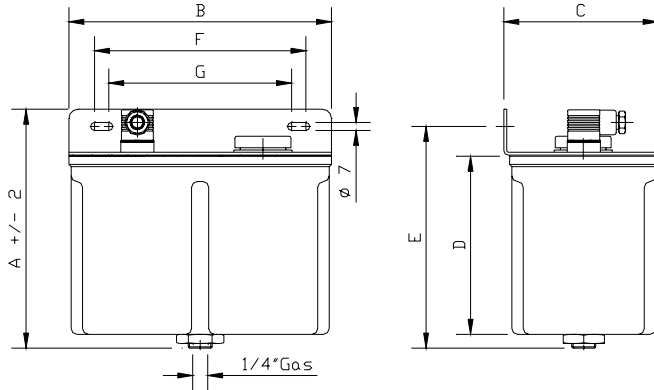

**COMPONENTS
RESERVOIRS**



CODICE <i>CODE</i>	CAPACITA' - L <i>CAPACITY - L</i>	LIVELLO ELETTRICO <i>LOW LEVEL SWITCH</i>	A MM	B MM	C MM	D MM	E MM	F MM	G MM
A72.079263	1.2 Poliestere / <i>Polyester</i>		161	148	123	108	146	132	125
A72.079264	2.2 Poliestere / <i>Polyester</i>		213	148	123	160	198	132	125
A72.079265	3.6 Poliestere / <i>Polyester</i>		208	230	135	155	193	185	160
A72.079269	6.0 Nylon		303	230	135	250	288	185	160
A72.079260	1.2 Poliestere / <i>Polyester</i>	***	161	148	123	108	146	132	125
A72.079261	2.2 Poliestere / <i>Polyester</i>	***	213	148	123	160	198	132	125
A72.079262	3.6 Poliestere / <i>Polyester</i>	***	208	230	135	155	193	185	160
A72.079268	6.0 Nylon	***	303	230	135	250	288	185	160

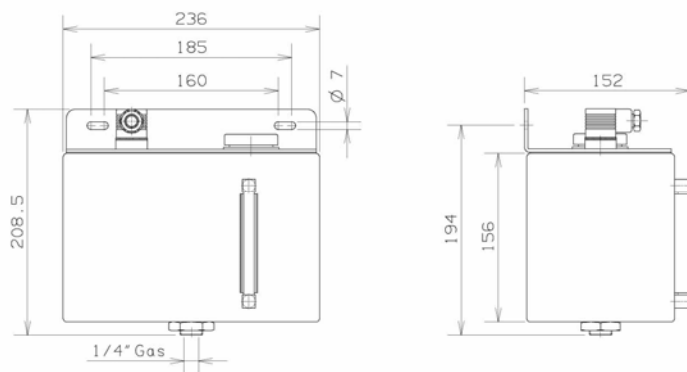

CODICE <i>CODE</i>	CAPACITA' - L <i>CAPACITY - L</i>	LIVELLO ELETTRICO <i>LOW LEVEL SWITCH</i>
A72.079399	3.6 Metallico / <i>Metallic</i>	***
A72.079399.SL	3.6 Metallico / <i>Metallic</i>	



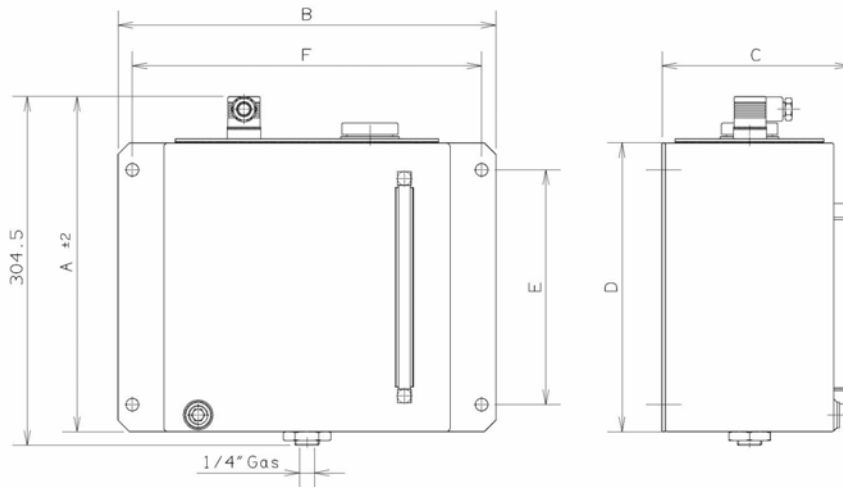

CODICE CODE	CAPACITA' - L CAPACITY - L	LIVELLO ELETTRICO LOW LEVEL SWITCH	A MM	B MM	C MM	D MM	E MM	F MM
A72.079415	8.0 Metallico / <i>Metallic</i>	***	305	330	163	252	205	305
A72.079324	12.0 Metallico / <i>Metallic</i>	***	305	355	196	252	205	330
A72.079420	50.0 Metallico / <i>Metallic</i>	***	452	560	266	400	300	530
A72.079415.SL	8.0 Metallico / <i>Metallic</i>		282	330	163	252	205	305
A72.079324.SL	12.0 Metallico / <i>Metallic</i>		282	355	196	252	205	330
A72.079420.SL	50.0 Metallico / <i>Metallic</i>		429	560	266	400	300	530



COMPONENTI
LIVELLI ELETTRICI

COMPONENTS
LOW LEVEL SWITCHES

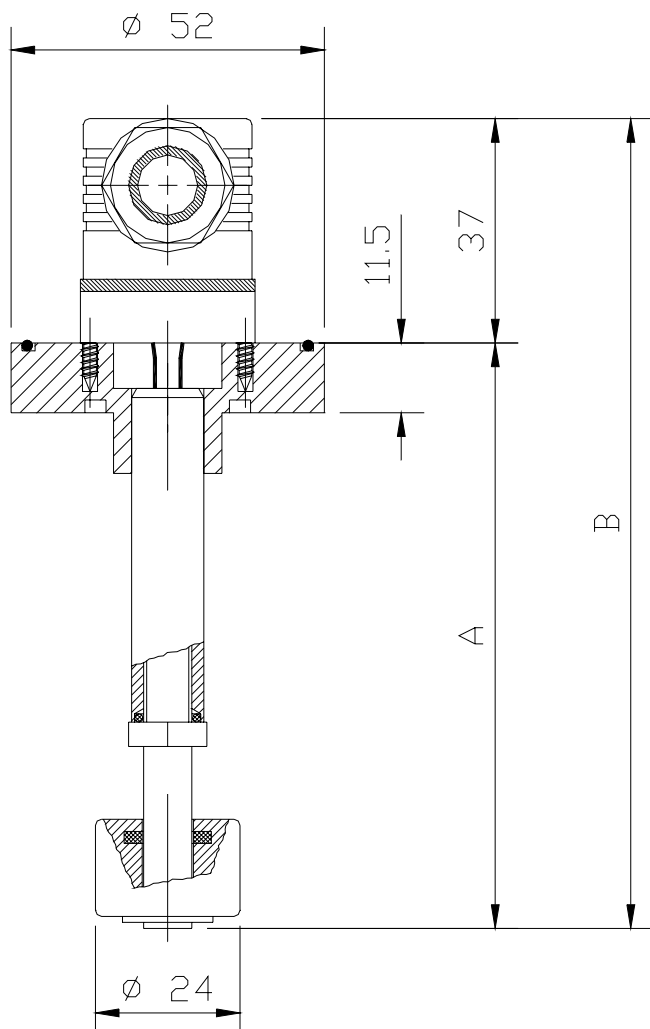

CODICE CODE	SERBATOIO L RESERVOIR L	A MM	B MM
A70.094040	1.20	97	133.5
A70.094029	2.20	144	181
A70.094029	3.60	144	181
A70.094037	6.00	240	277



COMPONENTI

RACCORDI RAPIDI PER COLLEGARE L'USCITA DEL SERBATOIO AD UN TUBO DA 8 MM

RACCORDO DIRITTO
STRAIGHT FITTING

A92.106123



COMPONENTS

PUSH-IN FITTINGS TO CONNECT RESERVOIR OUTLET TO AN 8 MM TUBE

RACCORDO A 90 GRADI
ELBOW FITTING

A92.106248

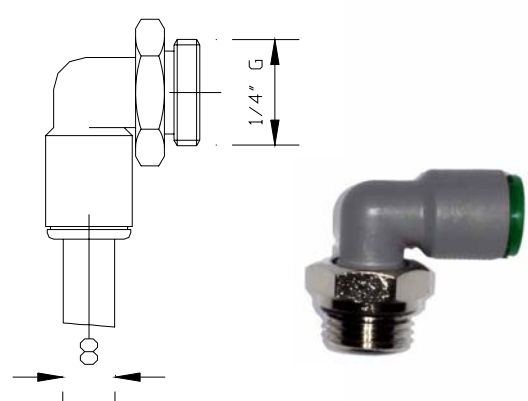

ADATTATORE PER MINI LUBETOOLS CON 1 O 2 POMPE

UNA POMPA

ONE PUMPS

A51.106208

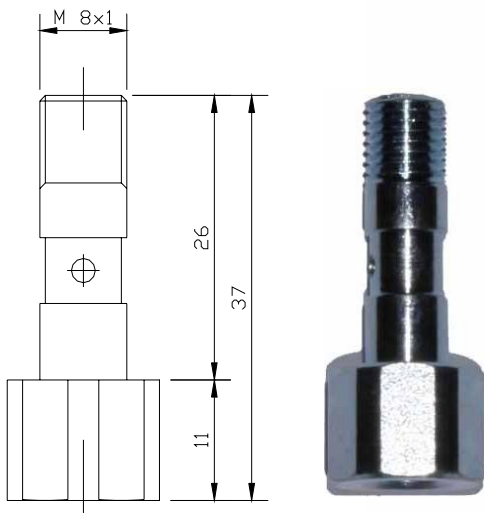

ADAPTORS FOR MINI LUBETOOLS WITH 1 OR 2 PUMPS

DUE POMPE

TWO PUMPS

A51.106215

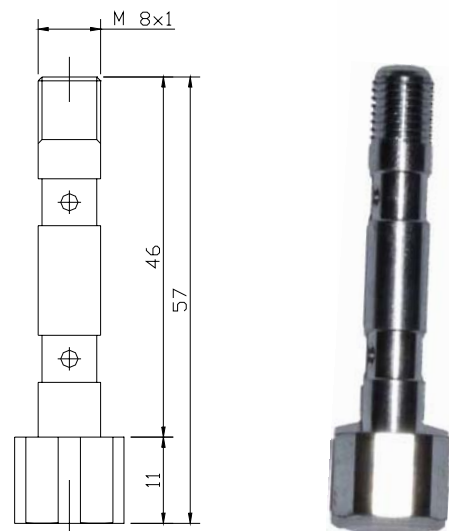

STAFFA PER INSTALLARE LE BASI DELLE POMPE (DA 1 A 6
POMPE)

BRACKET TO INSTALL THE BASE PUMPS (FROM 1 TO 6 PUMPS)

A85.120401

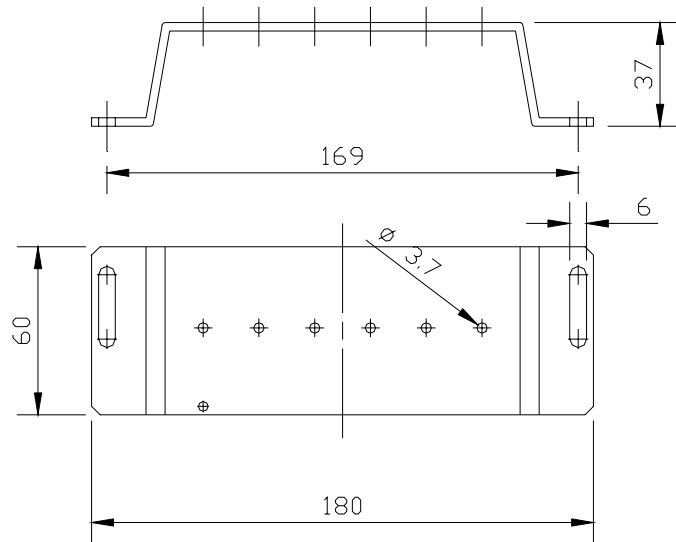

TIRANTI PER UNIRE LE BASI DELLE POMPE

TIE-RODS TO JOIN THE PUMP BASES

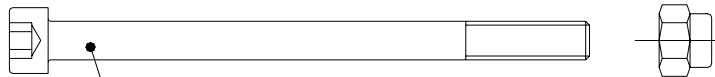
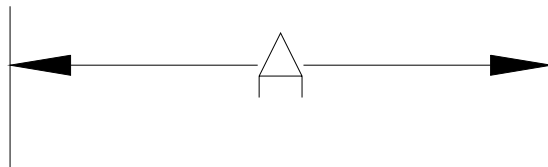

M5x UNI 5931



CODICE CODE	USCITE OUTLETS	A
A70.093167 (x2)	2	35
A70.093168 (x2)	3	55
A70.093169 (x2)	4	75
A70.093170 (x2)	5	95
A70.093171 (x2)	6	115



BASE POMPA
IL CODICE A70.093165 E' COMPLETO DI TUTTI GLI ITEM
MOSTRATI NEL DISEGNO

PUMP BASE
THE CODE A70.093165 IS COMPLETE OF ALL THE ITEMS
SHOWED IN THE BELOW DRAWING

A70.093165

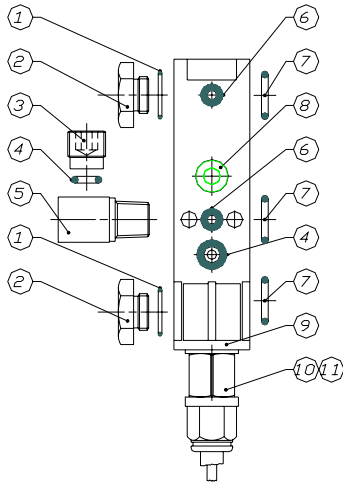

POS.	CODICE CODE	DESCRIZIONE	DESCRIPTION
1	A92.127109	"O"-RING 11x1	"O"-RING 11x1
2	A51.096055	TAPPO	PLUG
3	A73.087010	TAPPO	PLUG
4	A92.127108	"O"-RING 2018	"O"-RING 2018
5	03.231.0	ADATTATORE 90 GRADI	ELBOW ADAPTOR
6	A92.127106	"O"-RING 2010	"O"-RING 2010
7	A92.127109	"O"-RING 2037	"O"-RING 2037
8	UNI5931-M5X25	VITE M5x25 UNI 5931	SCREW M5x25 UNI 5931
9	A83.082081	BASE SINGOLA	SINGLE BASE
10	A70.093219	RACCORDO DI MANDATA + TUBO COASSIALE DA 5 M - 6 MM	DELIVERY FITTING + 5 M COAXIAL TUBE - 6 MM
11	A70.093228	RACCORDO DI MANDATA + TUBO COASSIALE DA 5 M - 8 MM	DELIVERY FITTING + 5 M COAXIAL TUBE - 8 MM

MICRO POMPA PNEUMATICA DA INSTALLARE SULLA BASE

MICRO PNEUMATIC PUMP TO BE INSTALLED ON THE BASE

A70.093463

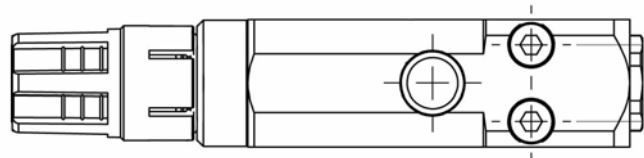
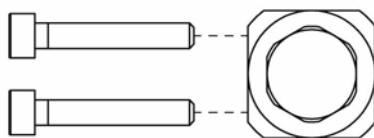

RACCORDI PER LA BASE DELLA POMPA

FITTINGS FOR PUMP BASE

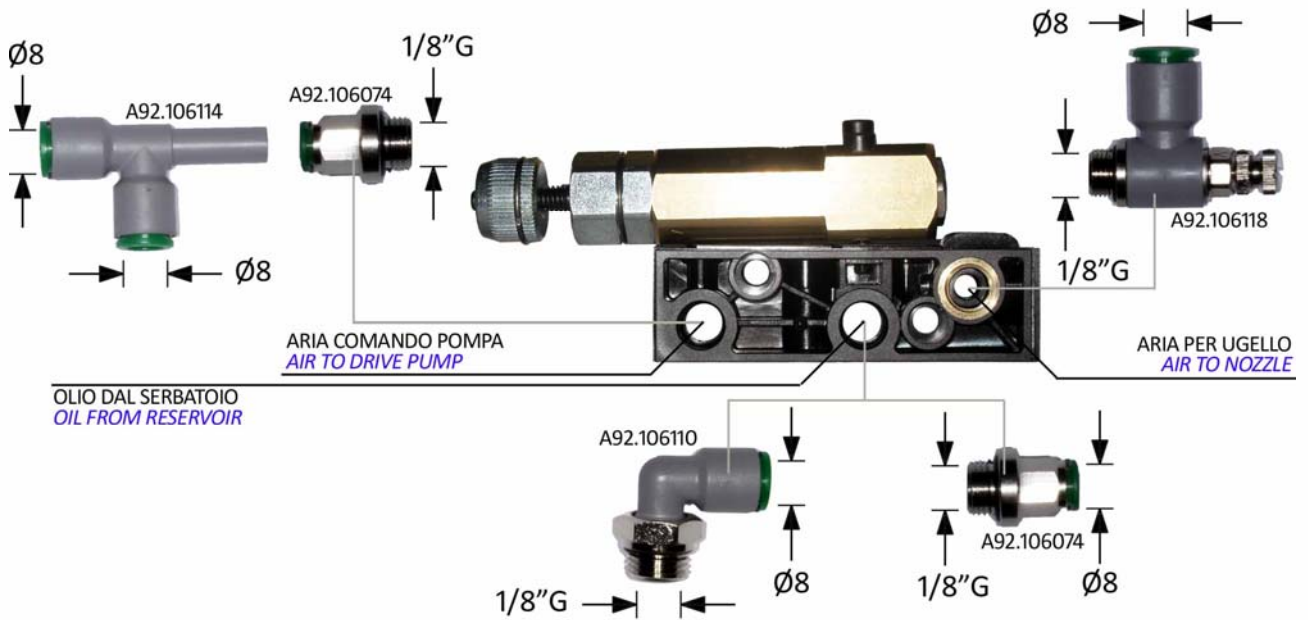

UGELLO COMPLETO DI RACCORDO PER TUBO 6 MM

NOZZLE COMPLETE OF FITTING FOR TUBE 6 MM

RACCORDO TUBO CON
DOPPIOCONO

NUT AND OLIVE FITTING

RACCORDO RAPIDO

PUSH-IN FITTING

A70.093172

A70.093180

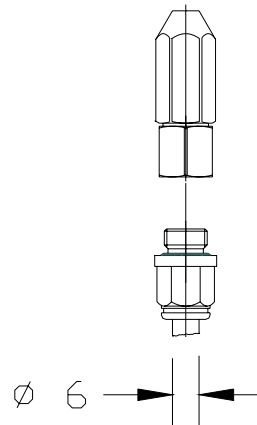
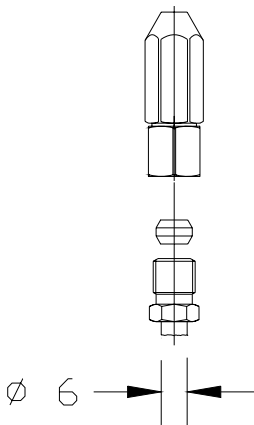

GENERATORE DI FREQUENZA COMPLETO DI BASE

FREQUENCY GENERATOR COMPLETE OF BASE

A72.079243

**	ARIA PER POMPE PNEUMATICHE	AIR FOR PNEUMATIC PUMPS
*	ARIA PER UGELLI	AIR FOR NOZZLE

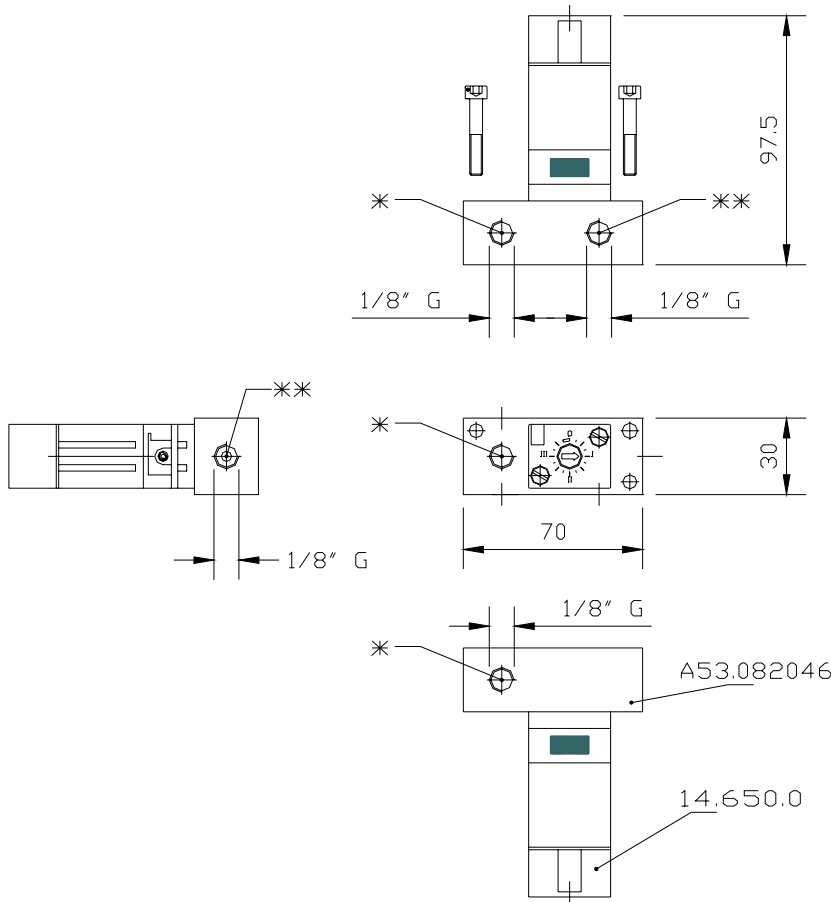

base A70.093491

RACCORDI BASE E TAPPO

BASE FITTINGS AND PLUG

A92.106110

A92.106074

A92.087058

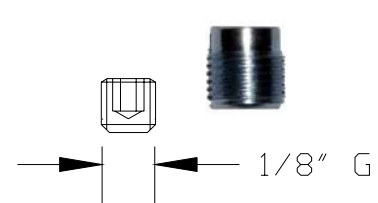
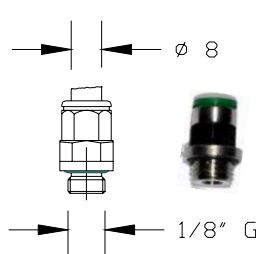
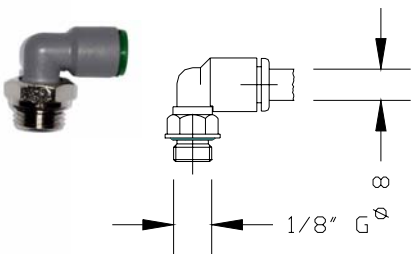

GENERATORE DI FREQUENZA COMPLETO DI BASE

FREQUENCY GENERATOR COMPLETE OF BASE

QUESTA VERSIONE VIENE UTILIZZATA PER LA SERIE MINI CON
UNA O DUE POMPE

THIS IS USED FOR THE MINI VERSION WITH ONE OR TWO
PUMPS

A72.079321

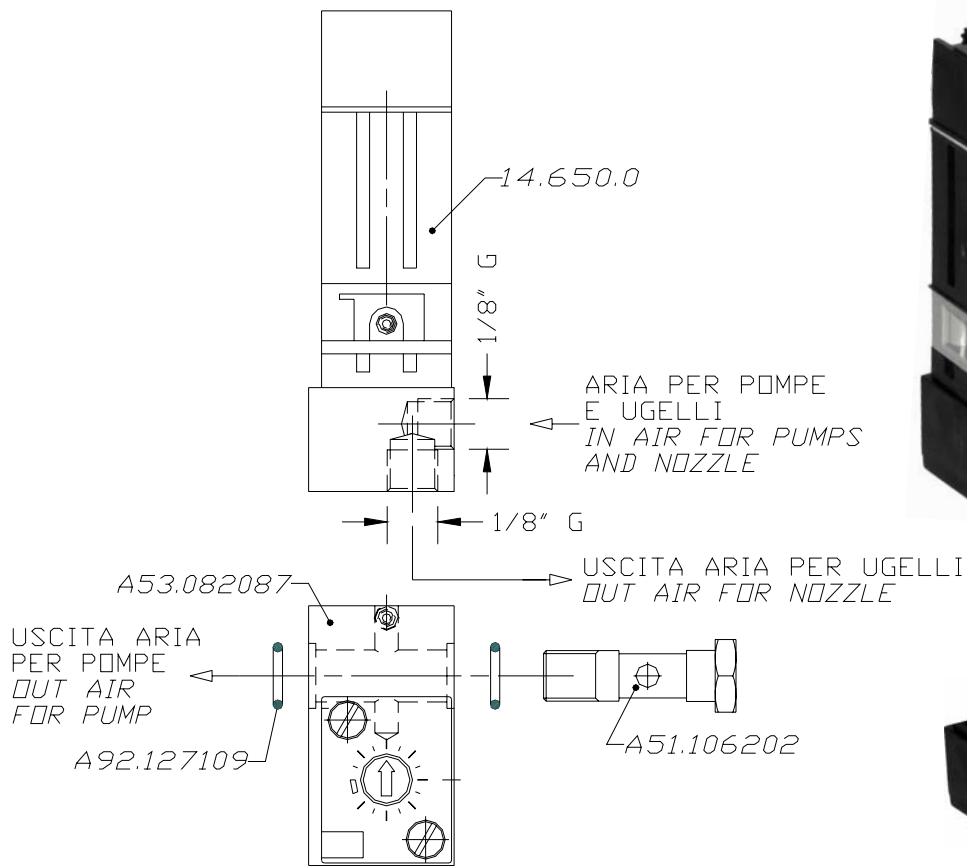

base **A70.093504**

RACCORDI BASE E TAPPO

BASE FITTINGS AND PLUG

A92.106110

A92.106074

A92.087058

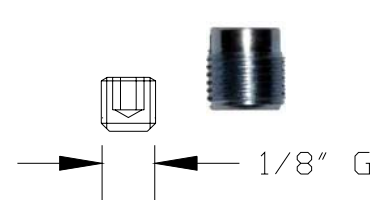
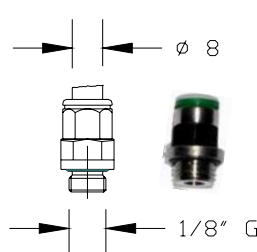
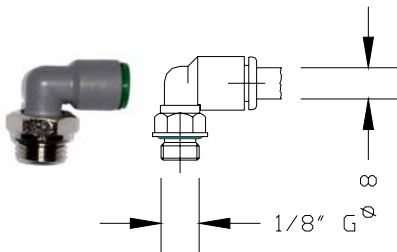

ELETTROVALVOLE

SOLENOID VALVES

Codice <i>Code</i>	Descrizione	<i>Description</i>	Immagine <i>Image</i>
<p>14.660.0</p> <p>14.660.1</p> <p>14.660.2</p> <p>14.660.3</p> <p>14.660.4</p>	<p>Elettrovalvola Connessioni: 1/4" Gas Diametro passaggio (mm): 6 Portata (NI/min): 620 Pressione max (BAR): 10</p> <p>Bobina 24 V DC Bobina 115 V AC Bobina 230 V AC Bobina 24 V AC</p>	<p>Solenoid valve Connection: 1/4" G Orifice size (mm): 6 Discharge (NI/min): 620 Max Pressure (BAR): 10</p> <p>Coil 24 V DC Coil 115 V AC Coil 230 V AC Coil 24 V AC</p>	
<p>14.663.5</p> <p>14.660.1</p> <p>14.660.2</p> <p>14.660.3</p> <p>14.660.4</p>	<p>Elettrovalvola Connessioni: 1/8" Gas Diametro passaggio (mm): 1,5 Portata (NI/min): 60 Pressione max (BAR): 10</p> <p>Bobina 24 V DC Bobina 115 V AC Bobina 230 V AC Bobina 24 V AC</p>	<p>Solenoid valve Connection: 1/8" G Orifice size (mm): 1,5 Discharge (NI/min): 60 Max Pressure (BAR): 10</p> <p>Coil 24 V DC Coil 115 V AC Coil 230 V AC Coil 24 V AC</p>	
<p>14.662.5</p> <p>14.662.1</p> <p>14.662.2</p> <p>14.662.3</p> <p>14.662.4</p>	<p>Elettrovalvola Connessioni: 3/8" Gas Diametro passaggio (mm): 10 Portata (NI/min): 1500 Pressione max (BAR): 10</p> <p>Bobina 24 V DC Bobina 115 V AC Bobina 230 V AC Bobina 24 V AC</p>	<p>Solenoid valve Connection: 3/8" G Orifice size (mm): 10 Discharge (NI/min): 1500 Max Pressure (BAR): 10</p> <p>Coil 24 V DC Coil 115 V AC Coil 230 V AC Coil 24 V AC</p>	



TUBI COASSIALI COMPLETI DI RACCORDO, ADATTATORE E UGELLO PER LA BASE DELLA POMPA

COAXIAL HOSES COMPLETE OF FITTING, ADAPTOR AND NOZZLE FOR THE PUMP BASE

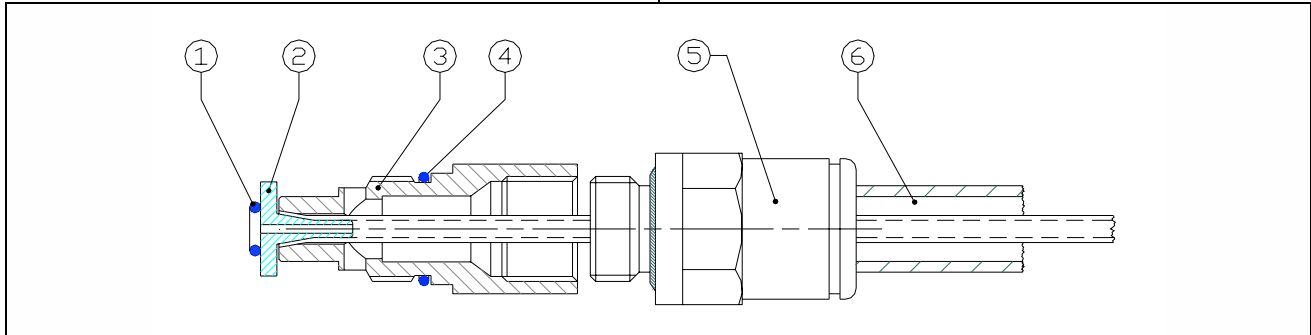

CODICI DI ORDINAZIONE

CODES TO ORDER

Mt	Ø6	Ø8	Ø10
1,5	A70.093458	---	---
3	A70.093453	---	---
4	A70.093438	---	---
5	A70.093219	A70.093228	A70.093475
6	A70.093253	A70.093257	---
7	A70.093254	A70.093258	---
8	A70.093255	A70.093259	---
9	A70.093256	A70.093260	---
10	A70.093250	A70.093249	A70.093476
15	A70.093412	A70.093418	A70.093477
20	---	A70.093469	A70.093478
25	---	---	A70.093479
30	---	A70.093470	A70.093471



POS	DESCRIZIONE	DESCRIPTION	CODICE - CODE
1	"O"-RING 3x1	O"-RING 3x1	A92.127034
2	BUSSOLA PORTA TUBO PER BASE	NOZZE FOR PUMP BASE	A52.090051
3	ADATTATORE	ADAPTOR	A51.106104
4	"O"-RING 8x1	"O"-RING 8x1	A73.127065
5	RACCORDO RAPIDO	PUSH-IN FITTING	*
6	TUBAZIONE COASSIALE	COAXIAL HOSE	**

	DESCRIZIONE	DESCRIPTION	CODICE - CODE
*	RACCORDO RAPIDO 1/8" TUBO 6 MM	PUSH-IN FITTING 1/8" HOSE 6 MM	A92.106113
*	RACCORDO RAPIDO 1/8" TUBO 8 MM	PUSH-IN FITTING 1/8" HOSE 8 MM	A92.106074
*	RACCORDO RAPIDO 1/4" TUBO 10 MM	PUSH-IN FITTING 1/4" HOSE 10 MM	03.214.0 + A92.106191

**			
Mt	Ø6	Ø8	Ø10
1	70.150.1	70.160.1	70.170.1
2	70.150.2	70.160.2	70.170.2
3	70.150.3	70.160.3	70.170.3
4	70.150.4	70.160.4	70.170.4
5	70.150.5	70.160.5	70.170.5
6	70.150.6	70.160.6	70.170.6
7	70.150.7	70.160.7	70.170.7
8	70.150.8	70.160.8	70.170.8
9	70.150.9	70.160.9	70.170.9
10	70.151.0	70.161.0	70.171.0
11	70.151.1	70.161.1	70.171.1
12	70.151.2	70.161.2	70.171.2
13	70.151.3	70.161.3	70.171.3
14	70.151.4	70.161.4	70.171.4
15	70.151.5	70.161.5	70.171.5
16	70.151.6	70.161.6	70.171.6
17	70.151.7	70.161.7	70.171.7
18	70.151.8	70.161.8	70.171.8
19	70.151.9	70.161.9	70.171.9
20	70.152.0	70.162.0	70.172.0
21	70.152.1	70.162.1	70.172.1
22	70.152.2	70.162.2	70.172.2
23	70.152.3	70.162.3	70.172.3
24	70.152.4	70.162.4	70.172.4
25	70.152.5	70.162.5	70.172.5
30	70.153.0	70.163.0	70.173.0



TUBI COASSIALI METALLICI COMPLETI DI RACCORDO, ADATTATORE E UGELLO PER LA BASE DELLA POMPA

METALLIC COAXIAL HOSES COMPLETE OF FITTING, ADAPTOR AND NOZZLE FOR THE PUMP BASE

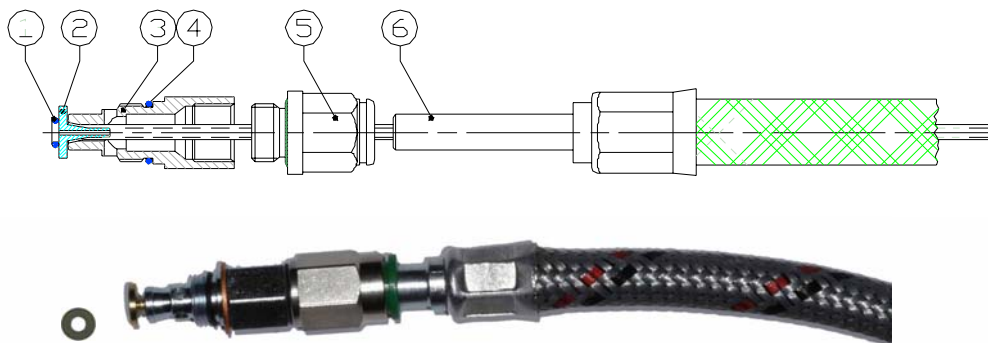

CODICI DI ORDINAZIONE

CODES TO ORDER

CODICE - CODE	DESCRIZIONE	DESCRIPTION
A70.093351	1 M TUBO COASSIALE CODULO 8 MM COMPLETO DI RACCORDO, ADATTATORE E UGELLO PER LA BASE DELLA POMPA	1 M COAXIAL HOSE TERMINAL 8 MM COMPLETE OF FITTING, ADAPTOR AND NOZZLE FOR THE PUMP BASE
A70.093352	2 M TUBO COASSIALE CODULO 8 MM COMPLETO DI RACCORDO, ADATTATORE E UGELLO PER LA BASE DELLA POMPA	2 M COAXIAL HOSE TERMINAL 8 MM COMPLETE OF FITTING, ADAPTOR AND NOZZLE FOR THE PUMP BASE
A70.093353	3 M TUBO COASSIALE CODULO 8 MM COMPLETO DI RACCORDO, ADATTATORE E UGELLO PER LA BASE DELLA POMPA	3 M COAXIAL HOSE TERMINAL 8 MM COMPLETE OF FITTING, ADAPTOR AND NOZZLE FOR THE PUMP BASE
A70.093354	4 M TUBO COASSIALE CODULO 8 MM COMPLETO DI RACCORDO, ADATTATORE E UGELLO PER LA BASE DELLA POMPA	4 M COAXIAL HOSE TERMINAL 8 MM COMPLETE OF FITTING, ADAPTOR AND NOZZLE FOR THE PUMP BASE
A70.093355	5 M TUBO COASSIALE CODULO 8 MM COMPLETO DI RACCORDO, ADATTATORE E UGELLO PER LA BASE DELLA POMPA	5 M COAXIAL HOSE TERMINAL 8 MM COMPLETE OF FITTING, ADAPTOR AND NOZZLE FOR THE PUMP BASE
A70.093356	6 M TUBO COASSIALE CODULO 8 MM COMPLETO DI RACCORDO, ADATTATORE E UGELLO PER LA BASE DELLA POMPA	6 M COAXIAL HOSE TERMINAL 8 MM COMPLETE OF FITTING, ADAPTOR AND NOZZLE FOR THE PUMP BASE
A70.093357	7 M TUBO COASSIALE CODULO 8 MM COMPLETO DI RACCORDO, ADATTATORE E UGELLO PER LA BASE DELLA POMPA	7 M COAXIAL HOSE TERMINAL 8 MM COMPLETE OF FITTING, ADAPTOR AND NOZZLE FOR THE PUMP BASE
A70.093358	8 M TUBO COASSIALE CODULO 8 MM COMPLETO DI RACCORDO, ADATTATORE E UGELLO PER LA BASE DELLA POMPA	8 M COAXIAL HOSE TERMINAL 8 MM COMPLETE OF FITTING, ADAPTOR AND NOZZLE FOR THE PUMP BASE
A70.093359	9 M TUBO COASSIALE CODULO 8 MM COMPLETO DI RACCORDO, ADATTATORE E UGELLO PER LA BASE DELLA POMPA	9 M COAXIAL HOSE TERMINAL 8 MM COMPLETE OF FITTING, ADAPTOR AND NOZZLE FOR THE PUMP BASE
A70.093360	10 M TUBO COASSIALE CODULO 8 MM COMPLETO DI RACCORDO, ADATTATORE E UGELLO PER LA BASE DELLA POMPA	10 M COAXIAL HOSE TERMINAL 8 MM COMPLETE OF FITTING, ADAPTOR AND NOZZLE FOR THE PUMP BASE



A70.093341	1 M TUBO COASSIALE CODULO 6 MM COMPLETO DI RACCORDO, ADATTATORE E UGELLO PER LA BASE DELLA POMPA	1 M COAXIAL HOSE TERMINAL 6 MM COMPLETE OF FITTING, ADAPTOR AND NOZZLE FOR THE PUMP BASE
A70.093342	2 M TUBO COASSIALE CODULO 6 MM COMPLETO DI RACCORDO, ADATTATORE E UGELLO PER LA BASE DELLA POMPA	2 M COAXIAL HOSE TERMINAL 6 MM COMPLETE OF FITTING, ADAPTOR AND NOZZLE FOR THE PUMP BASE
A70.093343	3 M TUBO COASSIALE CODULO 6 MM COMPLETO DI RACCORDO, ADATTATORE E UGELLO PER LA BASE DELLA POMPA	3 M COAXIAL HOSE TERMINAL 6 MM COMPLETE OF FITTING, ADAPTOR AND NOZZLE FOR THE PUMP BASE
A70.093344	4 M TUBO COASSIALE CODULO 6 MM COMPLETO DI RACCORDO, ADATTATORE E UGELLO PER LA BASE DELLA POMPA	4 M COAXIAL HOSE TERMINAL 6 MM COMPLETE OF FITTING, ADAPTOR AND NOZZLE FOR THE PUMP BASE
A70.093345	5 M TUBO COASSIALE CODULO 6 MM COMPLETO DI RACCORDO, ADATTATORE E UGELLO PER LA BASE DELLA POMPA	5 M COAXIAL HOSE TERMINAL 6 MM COMPLETE OF FITTING, ADAPTOR AND NOZZLE FOR THE PUMP BASE
A70.093346	6 M TUBO COASSIALE CODULO 6 MM COMPLETO DI RACCORDO, ADATTATORE E UGELLO PER LA BASE DELLA POMPA	6 M COAXIAL HOSE TERMINAL 6 MM COMPLETE OF FITTING, ADAPTOR AND NOZZLE FOR THE PUMP BASE
A70.093347	7 M TUBO COASSIALE CODULO 6 MM COMPLETO DI RACCORDO, ADATTATORE E UGELLO PER LA BASE DELLA POMPA	7 M COAXIAL HOSE TERMINAL 6 MM COMPLETE OF FITTING, ADAPTOR AND NOZZLE FOR THE PUMP BASE
A70.093348	8 M TUBO COASSIALE CODULO 6 MM COMPLETO DI RACCORDO, ADATTATORE E UGELLO PER LA BASE DELLA POMPA	8 M COAXIAL HOSE TERMINAL 6 MM COMPLETE OF FITTING, ADAPTOR AND NOZZLE FOR THE PUMP BASE
A70.093349	9 M TUBO COASSIALE CODULO 6 MM COMPLETO DI RACCORDO, ADATTATORE E UGELLO PER LA BASE DELLA POMPA	9 M COAXIAL HOSE TERMINAL 6 MM COMPLETE OF FITTING, ADAPTOR AND NOZZLE FOR THE PUMP BASE
A70.093350	10 M TUBO COASSIALE CODULO 6 MM COMPLETO DI RACCORDO, ADATTATORE E UGELLO PER LA BASE DELLA POMPA	10 M COAXIAL HOSE TERMINAL 6 MM COMPLETE OF FITTING, ADAPTOR AND NOZZLE FOR THE PUMP BASE

POS	DESCRIZIONE	DESCRIPTION	CODICE - CODE
1	"O"-RING 3x1	O"-RING 3x1	A92.127034
2	BUSSOLA PORTA TUBO PER BASE	NOZZE FOR PUMP BASE	A52.090051
3	ADATTATORE	ADAPTOR	A51.106104
4	"O"-RING 8x1	"O"-RING 8x1	A73.127065
5	RACCORDO RAPIDO	PUSH-IN FITTING	*
6	TUBAZIONE COASSIALE	COAXIAL HOSE	*

	DESCRIZIONE	DESCRIPTION	CODICE - CODE
*	RACCORDO RAPIDO 1/8" TUBO 8 MM	PUSH-IN FITTING 1/8" HOSE 8 MM	A92.106074
*	RACCORDO RAPIDO 1/8" TUBO 6 MM	PUSH-IN FITTING 1/8" HOSE 6 MM	A92.106113



TUBI FLESSIBILI METALLICI

METALLIC FLEXIBLE HOSES

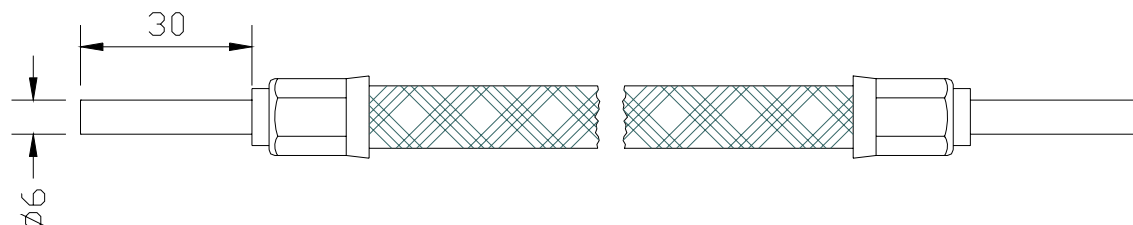

**	CODICI PER ORDINARE TUBAZIONI METALLICHE FLESSIBILI	CODES TO ORDER METALLIC FLEXIBLE HOSES
30.616.0.01000	1 M TUBO METALLICO 6 MM	1 M METALLIC HOSE 6 MM
30.616.0.02000	2 M TUBO METALLICO 6 MM	2 M METALLIC HOSE 6 MM
30.616.0.03000	3 M TUBO METALLICO 6 MM	3 M METALLIC HOSE 6 MM
30.616.0.04000	4 M TUBO METALLICO 6 MM	4 M METALLIC HOSE 6 MM
30.616.0.05000	5 M TUBO METALLICO 6 MM	5 M METALLIC HOSE 6 MM
30.616.0.06000	6 M TUBO METALLICO 6 MM	6 M METALLIC HOSE 6 MM
30.616.0.07000	7 M TUBO METALLICO 6 MM	7 M METALLIC HOSE 6 MM
30.616.0.08000	8 M TUBO METALLICO 6 MM	8 M METALLIC HOSE 6 MM
30.616.0.09000	9 M TUBO METALLICO 6 MM	9 M METALLIC HOSE 6 MM
30.616.0.10000	10 M TUBO METALLICO 6 MM	10 M METALLIC HOSE 6 MM

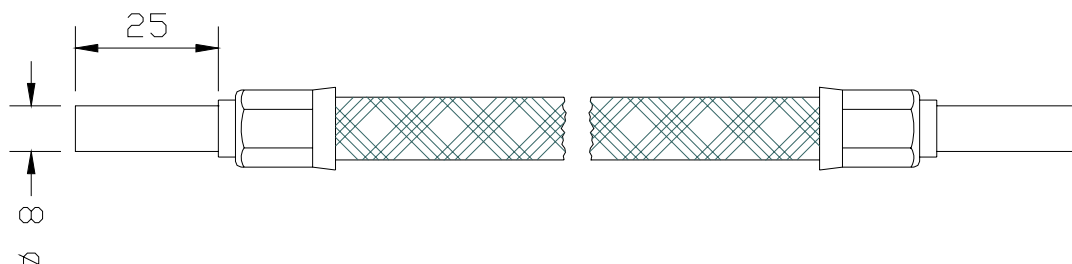

**	CODICI PER ORDINARE TUBAZIONI METALLICHE FLESSIBILI	CODES TO ORDER METALLIC FLEXIBLE HOSES
30.618.0.01000	1 M TUBO METALLICO 8 MM	1 M METALLIC HOSE 8 MM
30.618.0.02000	2 M TUBO METALLICO 8 MM	2 M METALLIC HOSE 8 MM
30.618.0.03000	3 M TUBO METALLICO 8 MM	3 M METALLIC HOSE 8 MM
30.618.0.04000	4 M TUBO METALLICO 8 MM	4 M METALLIC HOSE 8 MM
30.618.0.05000	5 M TUBO METALLICO 8 MM	5 M METALLIC HOSE 8 MM
30.618.0.06000	6 M TUBO METALLICO 8 MM	6 M METALLIC HOSE 8 MM
30.618.0.07000	7 M TUBO METALLICO 8 MM	7 M METALLIC HOSE 8 MM
30.618.0.08000	8 M TUBO METALLICO 8 MM	8 M METALLIC HOSE 8 MM
30.618.0.09000	9 M TUBO METALLICO 8 MM	9 M METALLIC HOSE 8 MM
30.618.0.10000	10 M TUBO METALLICO 8 MM	10 M METALLIC HOSE 8 MM



MAGNETI

MAGNETS

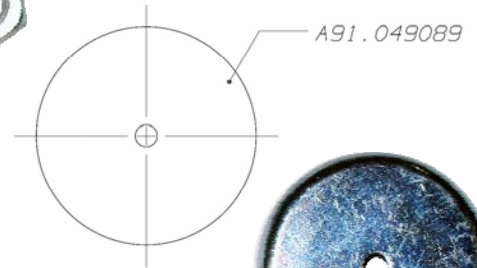
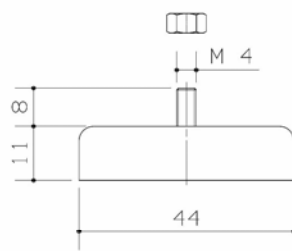
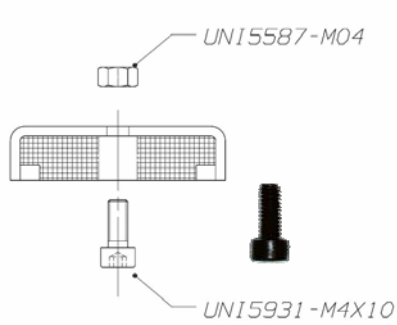

A70.093498

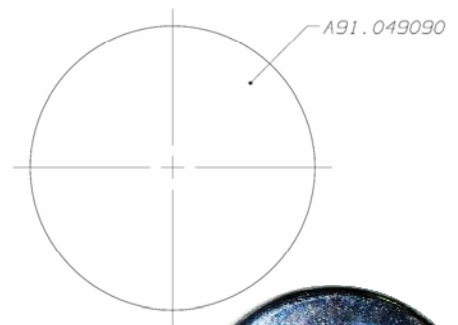
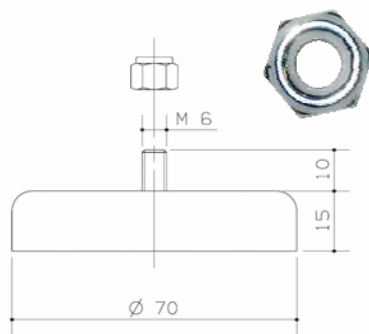
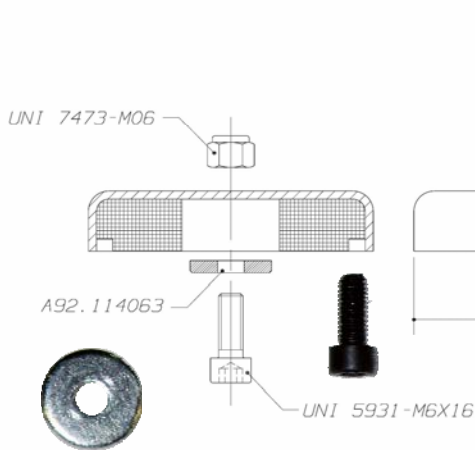

A70.093499

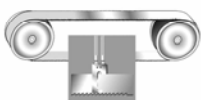

RACCORDI

FITTINGS

		TUBO HOSE	4 MM	TUBO HOSE	6 MM	TUBO HOSE	8 MM	TUBO HOSE	10 MM
	1/8" G	A92.106165		A92.106113		A92.106074			
	1/8" G	A92.106218		A92.106195		A92.106110			
	1 / 4" G			A92.106133		A92.106123		A92.106191	
	1 / 4" G			A92.106224		A92.106248		A92.106199	

