

Lubricating Oil Recirculation Systems with the progressive distributors ZP-

Lubricating oil recirculation systems with the progressive distributors ZP- forcibly feed up to about one hundred lubrication points successively with little fixed quantities of oil – even against high pressure.

The lubricating process for all connected lubrication points recurs as long as the pump supplies oil to the lubricant distributors. The oil running off from the lubrication points is led back into the oil tank and brought into circulation again.

Preferred fields of application

Gears, paper machines, punching machine, presses, machine tools.

Advantages of the oil recirculation systems with progressive distributors

- Exact metering for each lubrication point.
- Reliable lubrication even of lubrication points with high counterpressures as well as remote lubrication points.
- Low investment costs, little line cross sections
- Short pause times.
- Easy monitoring of functioning
- Compact design of the distributors.

Extent of supply

Oil tank, pump(s) and the most important accessory parts are combined to a space-saving aggregate.

We plan your lubrication system, deliver the whole accessories and effect the assembly on request.

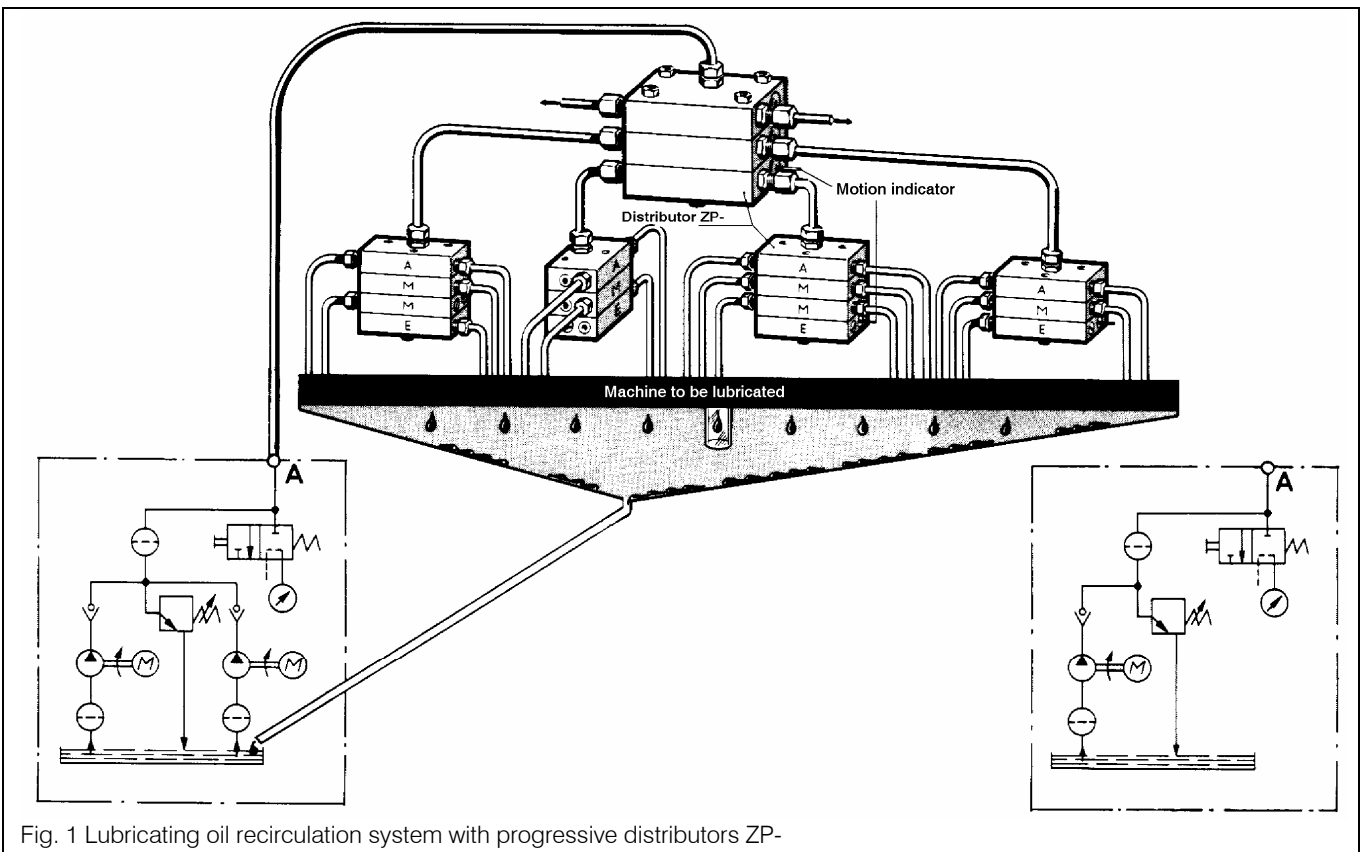

Fig. 1 Lubricating oil recirculation system with progressive distributors ZP-

Principle of operation

The oil tank takes up the oil running off from the lubrication points. In case of big tanks, parting walls increase the stability and simultaneously build chambers in which the reflux oil can calm down, deaerate, dehydrate and cool down. The size of the oil tank depends on the dwell time. This is the time being required to eliminate the impurities as completely as possible from the oil. The oil tank includes connections for feed and return lines, deaeration, oil level control and, if required, an additional heater.

An oil pump sucks in the oil and pushes it via the distributors to the lubrication points. The line pressure can be read off from a pressure gauge, which can be switched on by hand, and adjusted to a desired value with the help of a pressure relief valve. The dirt particles, which have not deposited in the tank so far, are retained by a filter.

To meter the quantities of oil supplied to the individual lubrication points, progressive distributors are used. These distributors proportion the lubricant received in little volumes equally and progressively and in a given order via the individual outlets to the connected lubrication points. If the lubricating process is interrupted by switching off of the pump or by shutting off the pressure line, the lubricating process restarts at this point with a new switching on.

Distributors (for details, please refer to brochure P_GB_ZPA; P_GB_ZPB)

The progressive distributors ZP-A and ZP-B are assembled from individual segments in accordance with the unit construction system and as per customer's order. Each distributor segment has a piston for the control of the lubricant.

During the piston stroke, the cylinder space made free by the piston fills up with lubricant, at the same time, the other piston end displaces the lubricant to a lubrication point.

The piston of a distributor segment ZP-A displaces 0.2 cm³ of lubricant with one stroke. The piston of a distributor segment ZP-B displaces (dependent on the piston diameter) 0.5; 1.2 or 2.0 cm³ of lubricant with one stroke. All distributor segments ZP-B have – regardless of the piston size – the same outside measurements.

The output volume per outlet of the distributors ZP-A can be increased by organizing cross connections of outlets. In case of the distributors ZP-B, the output volume per outlet can be increased by means of cross connections and longitudinal connections of outlets. For this purpose, the manufacturer removes appropriate seals from the inside of the distributor.

Pipework

The feed lines to the ZP-A distributors and the lubricant lines from the ZP-A distributors to the lubrication points are to be manufactured from 6 mm pipes. Suitable as feed lines to the distributors ZP-B are 10 mm pipes and as lubricant lines 6, 8 and 10 mm pipes. If it deals with movable lubrication points, one has to provide high-pressure hoses instead of the pipes.

Steel pipes are dimensioned according to the flow rates and operating conditions. For little flow rates, we use seamless drawn pipes with appropriate screwed pipe joints. For big flow rates, we use seamless steel pipes with welding neck flanges. After installation, the pipelines have to be cleaned by pickling and flushing.

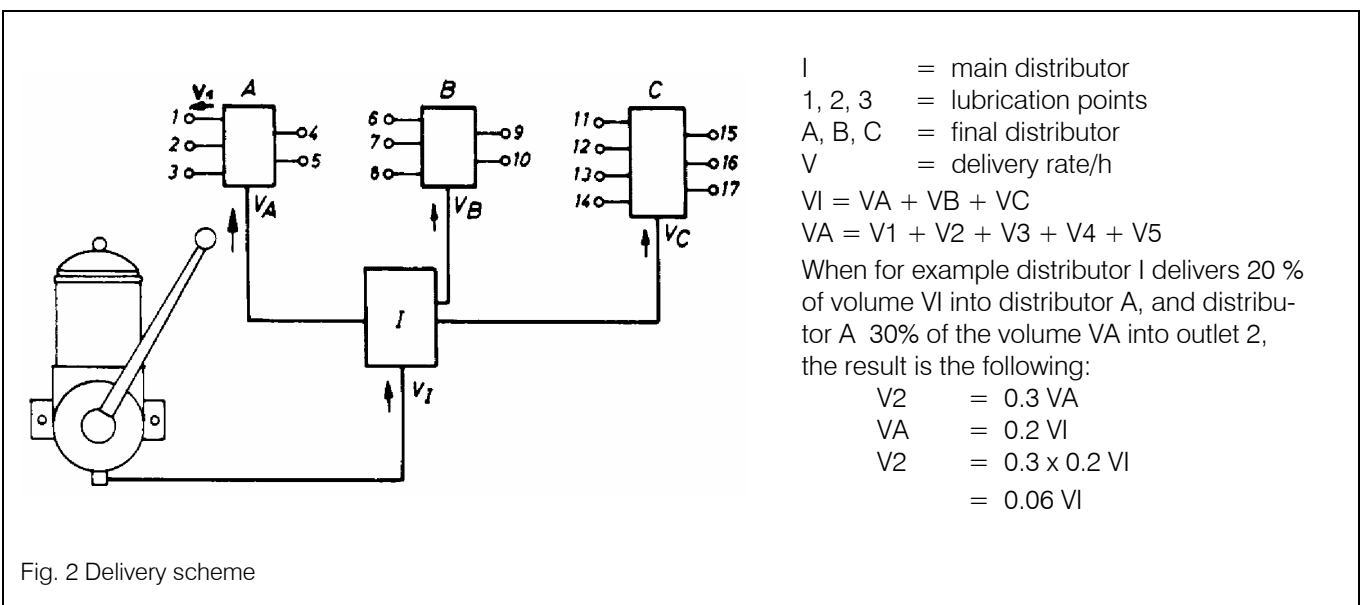

Oil reflux lines

The oil reflux lines have to be dimensioned according to the flow rates and led to the tank with an as constant as possible slope of 3 to 10 %.

Oil recirculation aggregates AG-E

The oil recirculation aggregates AG-E are delivered in a "ready for installation" condition. They include:

- 1 oil tank without or with electrical heater
- 1 or 2 feed pumps (the 2nd pump being intended as stand-by pump)
- 1 pressure-reducing valve
- 1 duplex filter

Electrical equipment

For the control of the lubricating oil recirculation system, a switch case is provided for practical reasons near the oil recirculation aggregate.

Possible versions:

- Switching on and off of the lubrication system by hand.
- Switching on and off of the lubrication system by the machine to be lubricated.
- Appropriate for systems with and without tank heater
- For systems without or with stand-by pump.
- For electrical checks of functioning.

Control facilities

Electrical monitoring of the min. flow rate

Damages at the feed pump, a too low oil level in the tank or a clogged filter result in the fact that the oil delivery does not take place or that the flow rate falls below the set-point. For the monitoring of the min. flow rate, one can install a flow indicator with variable switching point behind the filter into the main line. As long as the desired oil volume flows through the line, a white lamp lights up. When the oil volume falls below the desired value, a red warning lamp lights up and an acoustic signal is transmitted simultaneously.

Electrical monitoring of the min. pressure

Should a line or a distributor be blocked for some reason, the pressure in the line will increase. Exceeding of the max. pressure is indicated optionally via a contact making pressure gauge or via a pressure switch. Both appliances are installed behind the filter in the main line. Damages are indicated by a signal lamp and a horn.

Visual and electrical monitoring of the distributor functioning

Each progressive distributor is furnished with a motion indicator, which makes the motions of a distributor piston visible from the outside. As all pistons of a distributor system depend on each other in their functioning, it is sufficient to observe the double stroke of one motion indicator as proof of the functioning of the whole distributor system. When the distributor functioning is monitored electrically, a signal lamp is caused to flash up and to be extinguished by turns or a pulse counter is actuated.

Electrical flow control

Some damages, which may occur behind the distributors, are not signalized by the control facilities mentioned so far, e. g. pipe fractures of the lubricant lines. To ensure that such damages are signalized, too, one can provide flow control instruments directly before the lubrication points. If the planned quantity of oil is not delivered to the lubrication point in a given period of time, an acoustic signal sounds. At the same time, the warning lamp indicates which lubrication point is disturbed.

In view of the great expenditure involved, the use of an electrical flow control instrument will remain limited to particularly important lubrication points. In this case, however, one can do without the other control facilities.

Visual flow control of the oil reflux volume

If the drain lines from the lubrication points are easy to check, one can provide a visual flow control with falling-drop indicators.
