

Dual Line System for grease and oil

USE

Centralised lubrication systems with two main feed lines are chiefly used for the lubrication of machines and plant with a large numbers of lubrication points (up to over 1,000).

APPLICATIONS

Smelting plant, rolling mills, mining power stations, cement works, sugar refineries, breweries, construction machinery, etc.

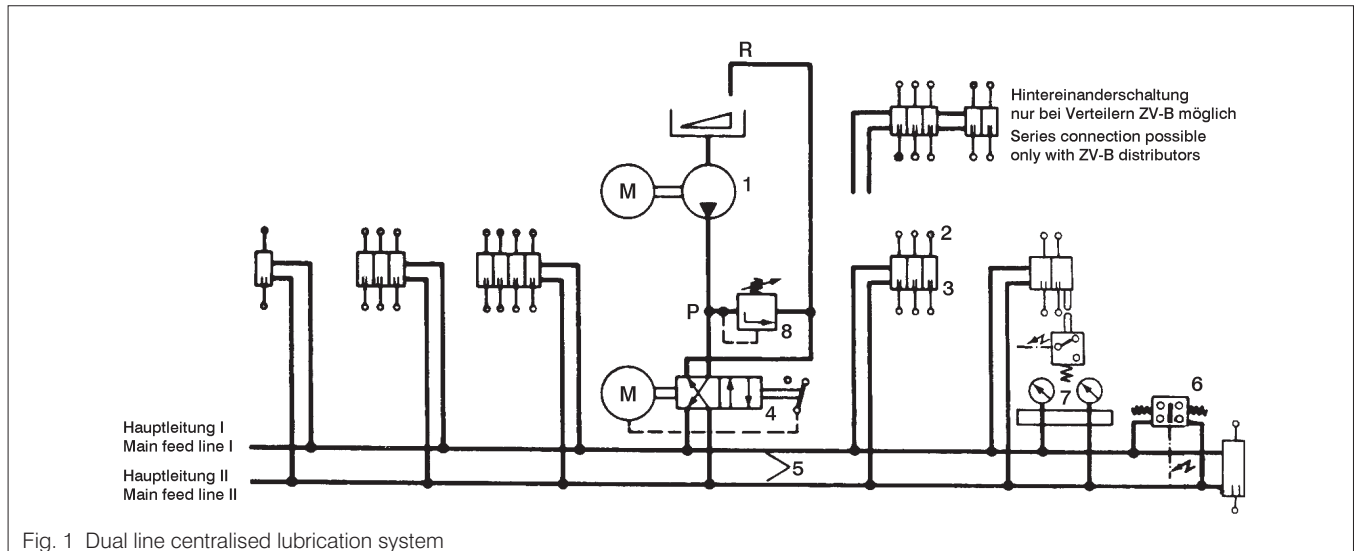

CONFIGURATION

The lubrication system consists principally of the pump (1), one 4/2-way or two 3/2-way change-over valves (4), the two main feed lines (5), the distributors (3) arranged close to the lubrication points, the lines leading to the lubrication points (2), switchgear (6) at the line end, the pressure gauge unit (7) and the controls. A pressure relief valve (8) is required to protect the pump from over pressure (see also Figs. 8 and 9).

ADVANTAGES

- Metering can be adjusted to meet the requirements of the individual lubrication points
 - by selection of the appropriate distributor size
 - by varying the metering setting
 - by varying the interval
- The metered quantity is independent of back pressure.
- The systems can at any time be extended by connection of additional distributors, or reduced by shutting down distributors or outlets.
- By using two 3/2-way change-over valves, both main feed lines can be pressure relieved during the interval, even in multi-line systems; lower pump pressure is therefore required in comparison to systems with lines under pressure during the interval.
- Special monitoring of critical lubrication points is made possible for each pair of distributor outlets using limit switches.
- The system can be operated fully automatically with variable intervals.
- Up to over 1,000 lubrication points at a distance of 100 metres can be lubricated, depending on the type of pump and lubricant.
- In all automatic systems, the patented switchgear SG - A, which initiates change-over, that is, the pressure change in the two main feed lines, as a function of the differential pressure at the line end, is used. Depending on temperature, lubricant and line dimensions, the optimum working pressure is adjusted automatically and there are, in comparison to systems where the switchgear is provided on the pump, the following advantages:
 - Pump load kept to a minimum.
 - Event at low temperature, which causes a slow pressure build-up (pipe friction), delivery of the correct quantity of lubricant is ensured by the switchgear SG - A being installed at the line end.
 - Additional monitoring of the main feed lines by means of the switchgear.

LUBRICATION PUMPS

Manual pumps

If the lubrication points of a machine require to be lubricated only after an extended interval, or a low price stand-by pump is required for medium size systems, then the manual pump type VB - B is recommended. The hand lever on the pump is moved backwards and forwards until an indicator pin is pushed out of the housing, indicating the end of the present pressure cycle. Simultaneously, an overflow valve is opened. The connections between the two main feed lines on the one hand, and the suction and pressure connection of the pump on the other are changed-over by a manual 4/2-way valve, that the second pressure cycle can be carried out by repeated forward and backward movements of the hand lever.

Electrical-operated pumps

For Dual Line Systems, various motor pumps may be used within the required pressure and delivery range (see table below).

Pneumatically-operated barrel pumps

Pneumatically-operated barrel pumps have, by contrast to other types of pump, the advantage that they can be fitted to 200 litre standard barrels and at the same time protect the contents from contamination since the lid remains in place. When the barrel is empty, the barrel pump is, depending on its size and weight, raised by hand, pulley, hoist or hydraulically, and the empty barrel replaced by a full one. In this way, replenishing necessary with other pumps is not required.

Positioning of pumps

With short lines, large line bores and heavy-duty pumps, positioning of the pumps is of secondary importance. In all other instances, the pumps should be positioned so that pressure losses in the lines are to be kept to a minimum. It is therefore recommended to position the pump in the middle between the furthest lubrication points.

In large installations, it is recommended to provide a fixed or portable reserve pump.

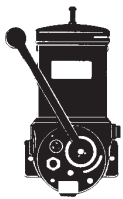
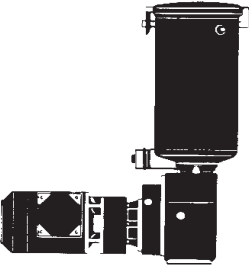
Type	Code no.	Drive	Reservoir capacity litre	Feed pressure max.	Delivery rate at	Pipe connection internal	Change-over device	Details see printlet
Manual pump VB - B 	21531 - 4531	manual	4	120 bar	each up and down stroke 2 cm ³	G 3/8	integral 4/2-way valve	21531 P 1e
Motor pump BM - B 	22113 - 1200	0.18 kW or 0.37 kW	8	400 bar	2 l/h	G 3/8	SA - K SA - V or 2 x SA - E	22113 P 1e
		0.37 kW			4 l/h			
	22113 - 1300	free shaft end dia. 14	15 or 30		i = 23 : 1 2 l/h			
					i = 23 : 1 4 l/h			

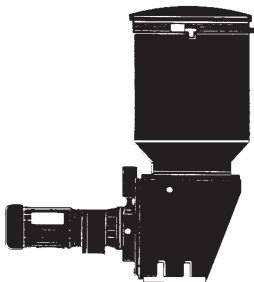
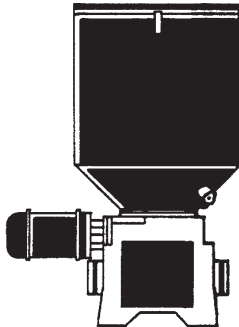
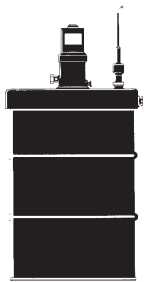
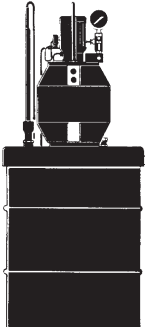
Type	Code no.	Drive	Reservoir capacity litre	Feed pressure max.	Delivery rate at	Pipe connection internal	Change-over device	Details see printlet
Motor pumps BS - B 	22123 - 1200	0.37 kW or 0.75 kW	30	400 bar	7 l/h	G 3/8	SA - V or 2 x SA - E	22123 P 1e
		0.75 kW	60		14 l/h			
		1.5 kW	60		22 l/h			
	22123 - 1300	free shaft end dia. 14	or 100		i = 18 : 1 7 l/h			
					i = 9 : 1 14 l/h			
					i = 5.5 : 1 22 l/h			
HA - III 	21514 - 2131	1.1 kW	100	400 bar	piston dia. 14 10 l/h	solderless screw joint with olive for outside pipe dia. 20	SA - V or 2 x SA - E	21514 P 1e
	21514 - 2231				piston dia. 20 20 l/h			
	21514 - 1131	free shaft end dia. 20			piston dia. 14 10 l/h			
	21514 - 1231				piston dia. 20 20 l/h			
Pneumatic barrel pumps BF - G 	22542 - 1311	pneumatic 3 to 9 bar	50 l or 200 l barrel	i = 45 : 1	per double 12 cm ³ stroke	G 1/2	preferred 2 x SA - E	22542 P 1e
	22542 - 1321							
	22542 - 1331				3 to 5.5 bar			
	22542 - 1511							
22542 - 1521								
22542 - 1531								
BF - E 	22543 - 1100	three-phase current IMB 14-71-C 105; 0.25 kW x 1500 min ⁻¹	200/216 l	400 bar	50 cm ³ (3.0 l/h)	G 3/8	SA - E	22543 P 1e
		IMB 14-71-C 105; 0,55 kW x 3000 min ⁻¹			100 cm ³ (6.0 l/h)			

EXAMPLES for multi - line systems

Working (shown for the beginning of each cycle)

1. Single-line system with 4/2-way valve

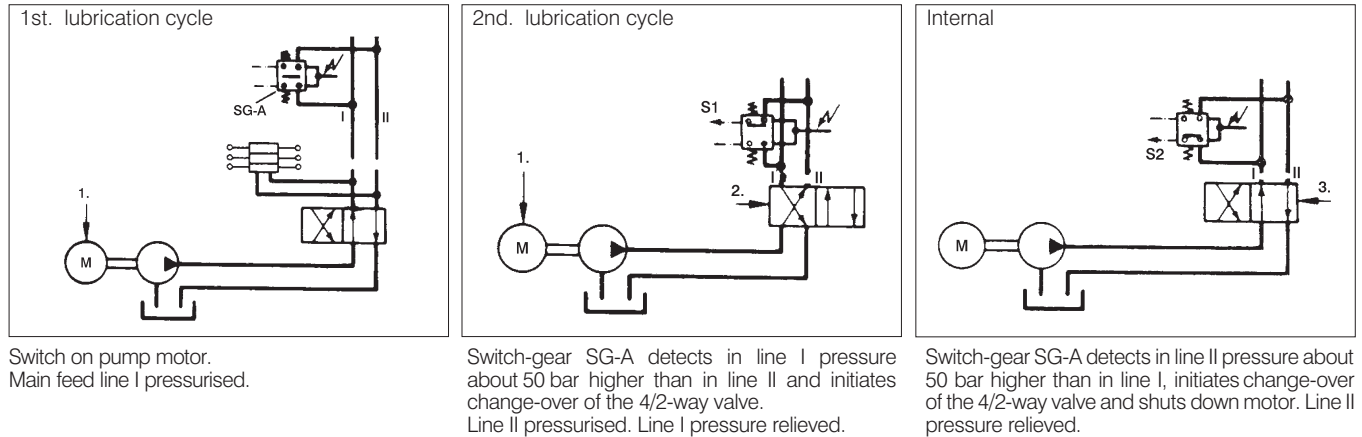

2. Multi-line system with 4/2-way valve

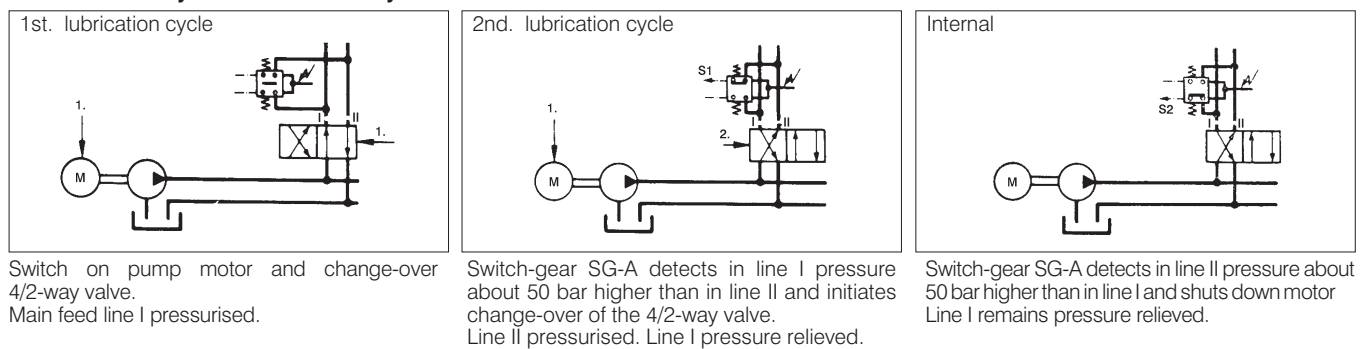

3. Single or multi-line system with two 3/2-way valve

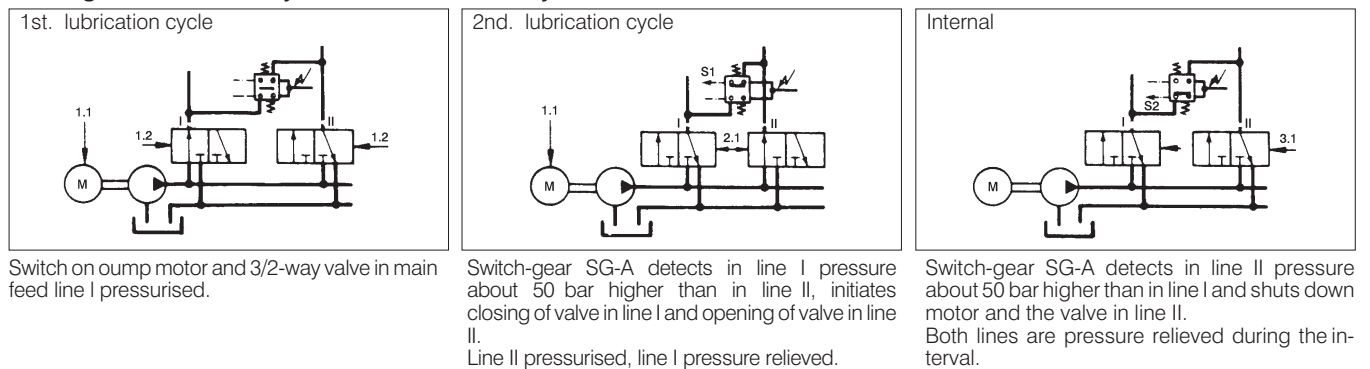

4. Half-cycle control (special edition)

On completion of the first lubrication cycle, that is, when half the total lubrication points have been lubricated, there follows the first half of the intervals, then the second lubrication cycle is initiated and so the second half of the lubrication points are lubricated. Finally, there is the second half of the interval. Application: in systems with long main feed lines and unfavourable pressures.

5. Connection to storage system

Working cycle as with multi-line systems. Signal for switching the pump on or off not required.

Examples for Dual - Line Centralized Lubrication Systems

.... with hand-actuated pump VB-B

Application: only for small, but rugged machines, which are lubricated at rather great intervals only. The 4/2-way valve for hand actuation is flange-mounted to the pump.

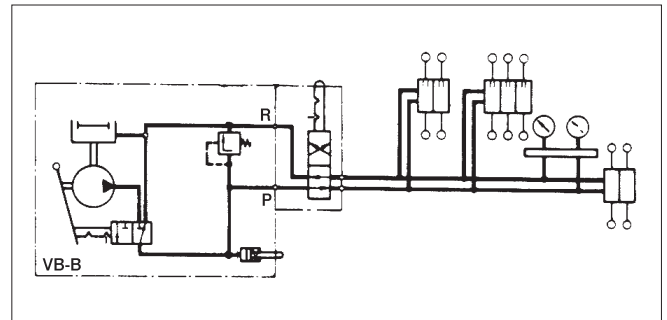

... with electromotor driven pump BM-B provided with a hydro-pneumatically controlled reverse valve.

The pump is switched on by a timing relay. When a pressure of approx. 150 bar has been reached at the pressure connection of the pump, the 4/2-way valve, which is flange-mounted to the pump, is switched, and main line II is pressurized. When the pressure reaches 150 bar once again, the 4/2-way valve is brought into the first switch position, and the pump is switched off.

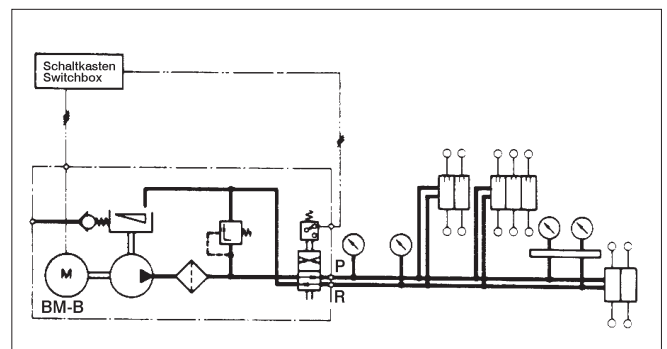

.... with electromotor driven pump BM - B (or BS-B or HA III), separate electromotor actuated 4/2-way reverse valve SA - V and switching device SG-A at the end of the line.

When the current supply is switched on, the pump is actuated and main line I and main line II are pressurized one after the other. As soon as a differential pressure of 50 bar is reached at the end of the main line, the 4/2-way valve is brought into the starting position (as shown on the sketch), and the motor is switched off.

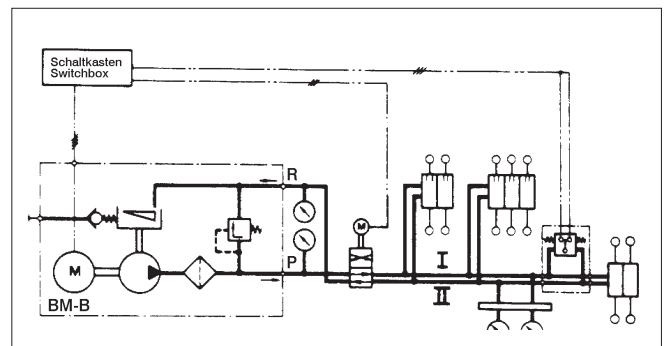

.... with electromotor driven pump BS-B (or BM-B or HA III), two pneumatically actuated 3/2-way valves SA-E and switching device SG-A at the end of the line.

At first, main line I is pressurized by the control. When the differential pressure at the end of the line is 50 bar, main line II is pressurized and main line I is relieved. As soon as a differential pressure of 50 bar is signaled once again at the end of the line, main line II, too, is relieved. Consequently, both main lines are relieved during the lubrication pause.

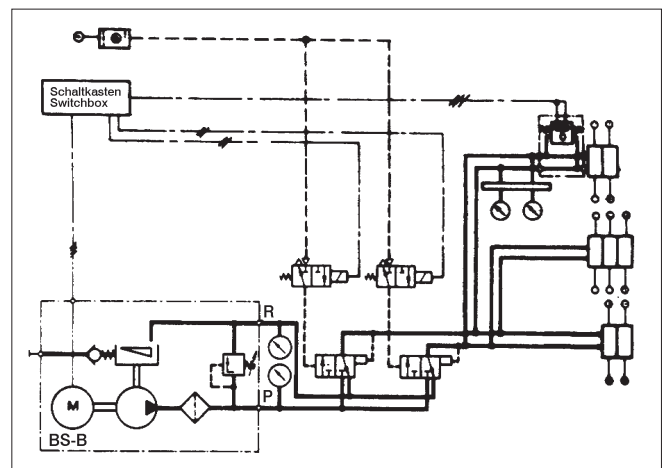

Examples for Dual - Line Centralized Lubrication Systems

.... with **electromotor driven pump HA III** (or BM-B or BS-B) as well as electromotor driven 4/2-way reverse valves SA-V and two switching devices SG-A at the end of the line of each strand.

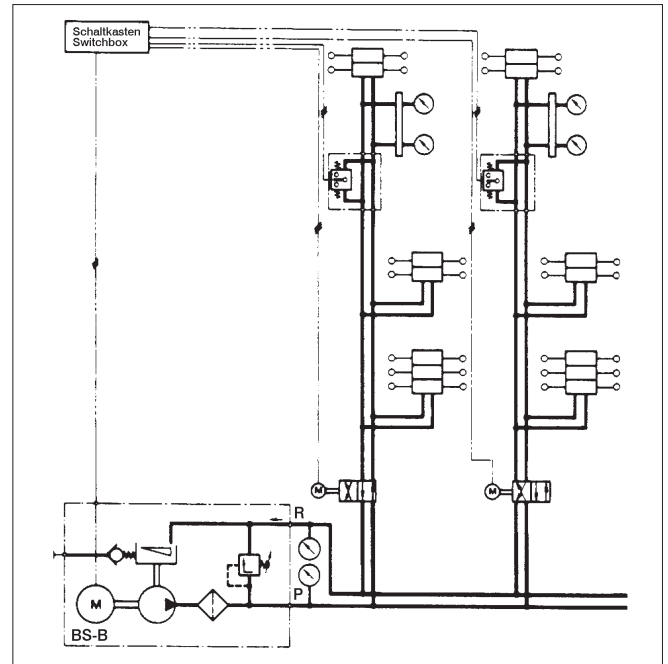

.... with **pneumatically driven drum pump BF-G**, four pneumatically actuated **3/2-way reverse valves SA-E** and two switching devices SG-A at the end of the line of each strand. Each of the two strands is independent from the other one and/or can only be pressurized when the other one is depressurized. All lines are relieved during the lubrication pause.

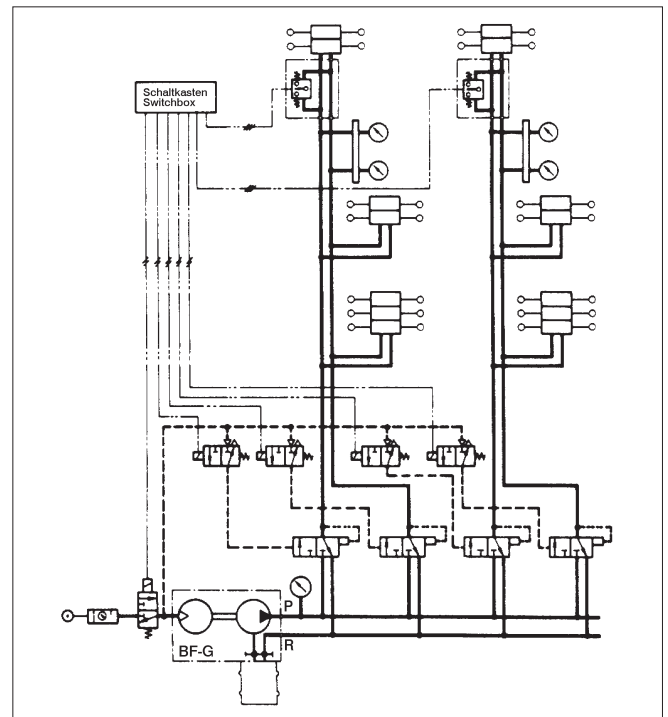

.... relief of both main lines of a strand by connecting in series two electromotor actuated 4/2-way reverse valves SA-V.

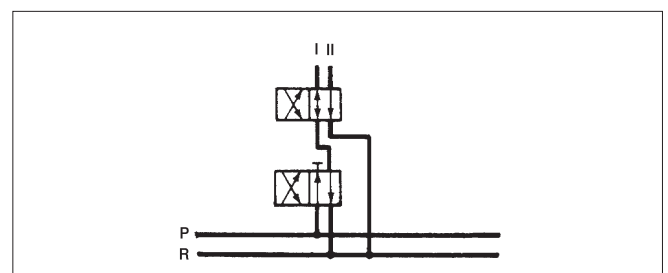

DISTRIBUTORS

(For further details see printlet 35712 P 2 e)

Distributors serve to deliver exact quantities of lubricant, irrespective of back pressure, into the lubricant lines to the lubrication points.

Distributors type ZV-B and ZV-C are suitable for use with dual line systems.

- ZV - B for maximum metered quantities of 0.5 or 1.5 cm³, 3.0 per outlet
- ZV - C for maximum metered quantities of 15 cm³ per outlet

Distributors type ZV-B are available with 1 to 8 outlets and distributors type ZV-C with 1 to 4 outlets. In distributors with an uneven number of outlets, two outlets are joined to from a single outlet. This outlet delivers double the quantity for the same setting.

Distributor designs

- with metering screw for full, half or quarter of the maximum quantity, (distributor type ZV - B only).
- with infinitely variable metering adjustment between almost zero and maximum as well as indicator for piston movement during lubrication cycle and piston position (all distributor types).
- with adjuster and limit switch to signal end of stroke position via pilot lights or pulse monitor systems (type ZV-B, 1.5 cm³ only).

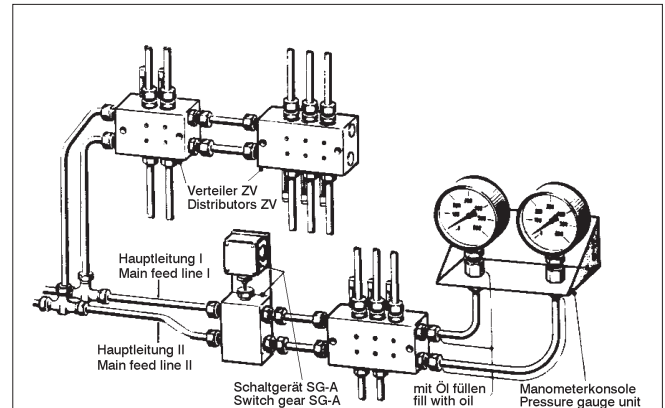

Fig. 2
Connection of distributor via branch lines (parallel connection) to the two main feed lines. Suitable for all distributor types.

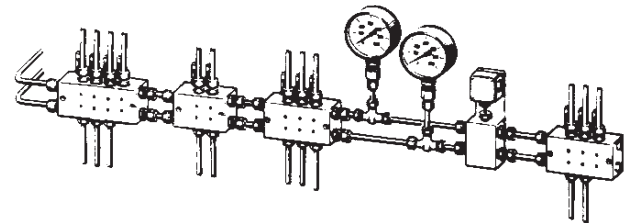

Fig. 3
Series connection of type ZV-B distributor. Installation costs are lower than the example in Fig. 2. The layout is restricted to smaller systems on account of the pressure drop inside the distributors. A combined parallel-series system is preferred for larger installations.

CHANGE-OVER AND SHUT-OFF DEVICES for grease and oil

The purpose of the change-over devices is to alternately pressurise both main feed lines, so that first one half and then second half of the lubrication points connected to the distributors is lubricated.

In a dual line centralised lubrication system, either one 4/2-way valve or two 3/2-way valves are used, i.e., one 3/2-way valve for each line. The higher cost of two 3/2-way valve system as against one 4/2-way valve is offset by the fact that both main feed lines are fully pressure relieved during the interval, i.e. connected to the pump suction chamber. In this way, the pump always delivers against low pressure in the main feed line.

TYPES AVAILABLE:

Manual 4/2-way valve

mounted on pump type VB-B (extra).

Solenoid operated valve

suitable for oil only. Available on request.

4/2-way valve SA-V with two open positions.

Actuated by 24 V d.c. geared motor. The high torque of the electric motor ensures that change-over takes place in under 0.5 seconds, even with stiff grease at low temperatures.



4/2-way valve type SA-H with one closed position and one open position (4/2-way cock).



Actuated by 24 V d.c. geared motor. Suitable for isolating one in multi-line systems.

3/2-way valve SA-E

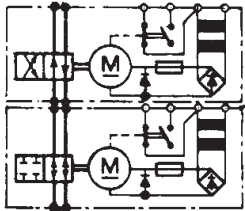
Actuated pneumatically at 2 - 3 bar (above 1/100 of system pressure).

For pre-selection use solenoid or pneumatic 3/2- or 5/2-way valves NW 2 or larger.

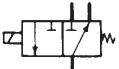
Symbol	Designation	Characteristics	max. pressure	Code no.	Printlet
electrically actuated 	4/2 - way valve SA - V	220 V	400 bar	34133 - 1311	34133 PB 2e
	4/2 - way valve SA - H			34133 - 1321	
pneumatically actuated 	3/2 - way valve SA - E	Compressed air 2 to 4 bar	400 bar	38141 - 1111	38141 PB 1e

Symbol	Designation	Characteristics	Protection cl.	Voltage	Code no.
Pre-selection valves for 3/2-way valve SA - E 	3/2 - way valve, electrically actuated, with return spring	NW 2.2	IP 65	24 V 220 V	73611 - 6213 73611 - 6223
	5/2-way valve, electrically actuated	NW 4	IP 65	224 V 220 V	73611 - 7313 73611 - 7323
	5/2-way valve, pneumatically actuated	NW 4 min. control pressure 1.8 bar		---	73611 - 7213

PRESSURE MONITORING, CONTROL AND PRESSURE RELIEF

Pressure gauge unit

visual indication of lubricant pressure and/or pressure differential between the two main feed lines. It should preferably be mounted at the end of the main feed line (upstream of switchgear type SG-A).

Switch-gear SG-A



used in dual line centralised lubrication systems with electrically or pneumatically operated pumps and should be mounted upstream of last distributor to receive the pressure in the main feed lines. As a rule, that is the distributor furthest away from the change-over device.

When the pressure differential between the two main feed lines reaches 50 bar, the switchgear transmits an electrical pulse which causes the change-over device to a pre-determined position depending on which of the two lines has the higher pressure. The pulse is also used to monitor the pressure change in the main feed lines.

Pressure relief valve

While pneumatically operated pumps stop automatically when excessive back pressure is experienced, electrically driven pumps must be protected against overload by a pressure relief valve. The pumps type BM-B and HA III have built-in or attached pressure relief valves. Pumps without pressure safety devices should be provided with a pressure relief valve between the pressurised and pressure relieved lines.

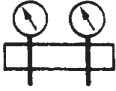
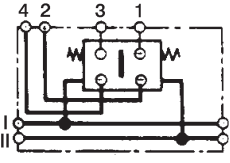
The manual pumps type VB-B also have a built-in pressure relief valve.

Symbol	Designation	Pressure gauge range	Pressure	Code no.	Printlet
	Pressure gauge unit	0 to 250 bar 0 to 600 bar	to 200 bar to 400 bar	65119 - 1221 65119 - 1231	65119 PB 1
	Switch-gear type SG - A	electrical connection max. 500 V, 15 A	change-over pressure 50 bar	34184 - 1111	34184 PB 1
	Pressure relief valve type SA - G	Range of adjustment 0 to 400 bar		38131 - 1111	38131/32 PB 2

Progressive distributors in branch lines

By using progressive distributors in branch lines, each outlet of a distributor type ZV can supply up to about 12 lubrication points. Progressive distributors have a fixed delivery of 0.2, 0.5, 1.2 or 2.0 cm³ per outlet and stroke. The operation of the distributor and thus the lubricant delivery to all lubrication points connected to the distributor, can be monitored by a limit switch.

(For further details see publication X 30 P 1e and 35500 P 1e).

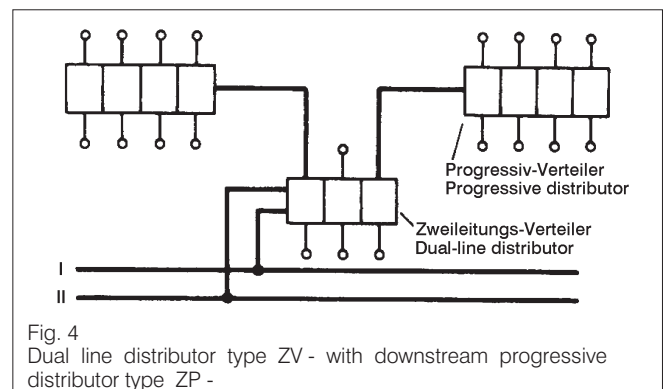

Grease Spraying

If it is desired to use a dual line centralised grease lubrication system at the same time for grease spray lubrication of gearwheels, conveyors, chains, etc., it should first be verified whether the relative lubrication points can be greased with the same lubricant and secondly whether the greasing frequency is identical.

In the system outlined in Fig. 5, the compressed air required for spraying the grease is purified by filter and adjusted to the required pressure by a pressure regulator. The downstream 3/2-way solenoid valve is arranged in such a manner that a space is filled with air during the lubrication interval. A quantity of grease metered by the ZV-distributor is delivered to the spray points in the first lubrication cycle. When the switchgear SG-A transmits a signal, the 3/2-way solenoid valve is energised and the pre-determined air sprays the grease through the nozzles. At the start of the interval, the solenoid valve is de-energised and the air space is replenished.

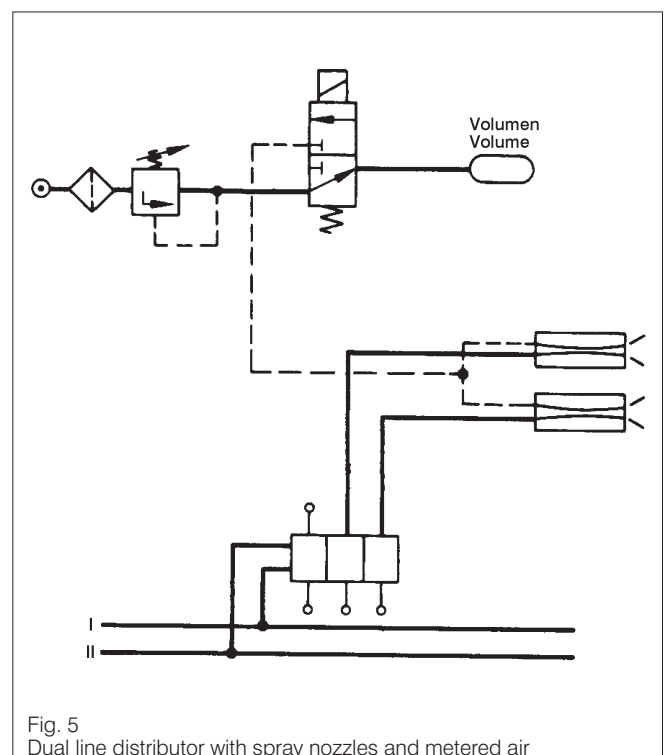

Monitoring

The switchgear at the line end, together with an additional timer, checks whether, during the monitoring period, a change of pressure has taken place twice in the main feed lines. The points checked are: pump pressure, reservoir contents, operation of the change-over device, fracture in the main feed lines.

If the distributor operation is also to be monitored, one limit switch is required for every two opposing distributor outlets

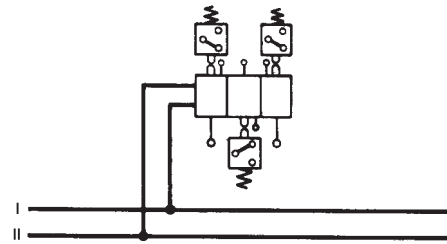

Fig. 6
Monitoring the distributor operation by limit switch on the distributor

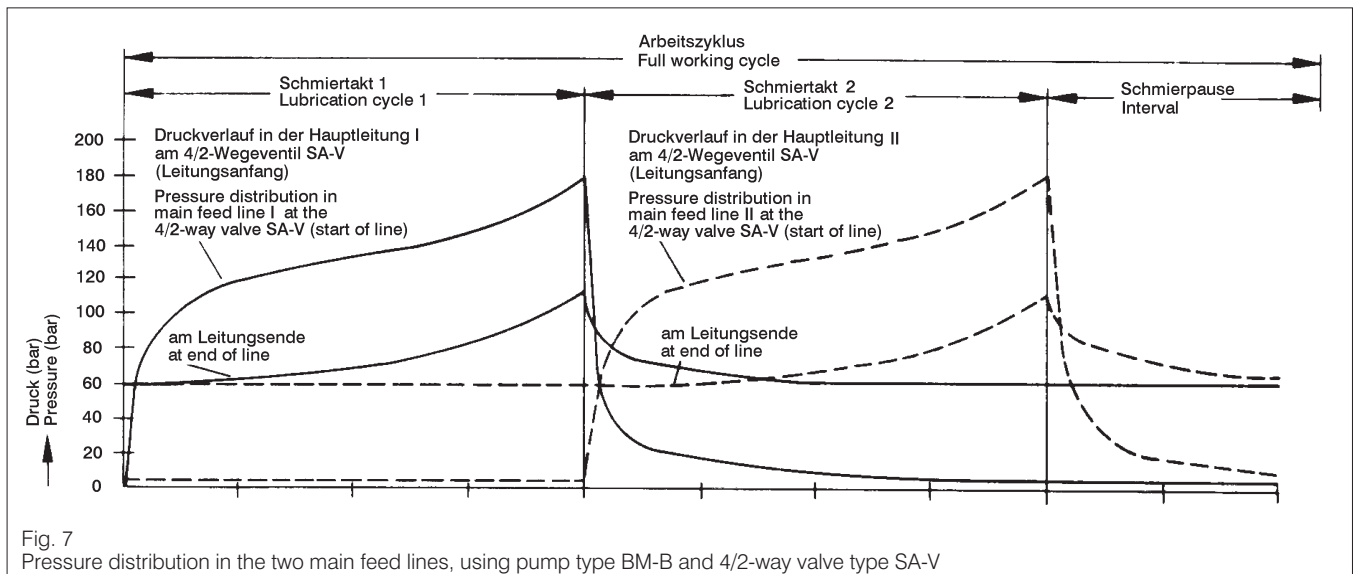

Fig. 7
Pressure distribution in the two main feed lines, using pump type BM-B and 4/2-way valve type SA-V

ELECTRICAL CONTROL SYSTEMS

The electrical control systems for DELIMON centralised lubrication systems employ standard circuitry. Some of the control systems may be used for installations both with valves type SA-V and type SA-E.

The lubrication systems may be operated continuously, for example, during start-up or automatically (with intervals).

We have developed special control module for dual line systems, code no. 66202-3001.

For detailed information, please ask for the relevant description indicating the code number.

We also supply complete switch cabinets in which is above mentioned module are integrated.