

# DD & DM Valves

## Dualine, Grease & Oil

### General

DD and DM Valves are completely hydraulic in operation and will deliver either oil or grease. These Dualine valves are also fully and individually adjustable in regard to discharge quantity and are equipped with operational indicators. Each DD valve serves two bearings; however, by a simple method of cross-porting, it will serve one. Therefore, a four valve block, as an example, can actually serve anywhere between four and eight bearings. DM series valves always have one discharge port per valve section located on the bottom of the valve. DD and DM valves can be supplied in several basic discharge capacities and are available in blocks consisting of one, two, three or four valves.



### Operation

Pressurized lubricant entering the valve forces the pilot piston down, allowing pressure to be applied to top of the main piston. The main piston begins to move down under pressure, forcing lubricant from its chamber, past the lower land of the pilot piston and out the discharge line to the bearing. When pressure in the supply line is reversed, lubricant then enters valve and forces the pilot piston up, allowing pressure to be applied to bottom of main piston, which begins to move up, forcing lubricant from its chamber, past the upper land of the pilot piston and out the second discharge line to the bearing.

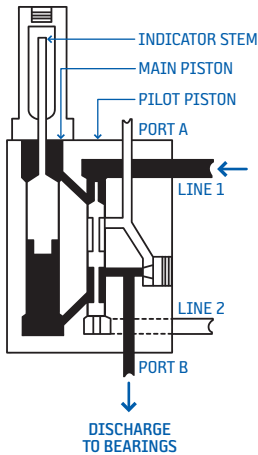

#### DD Valve

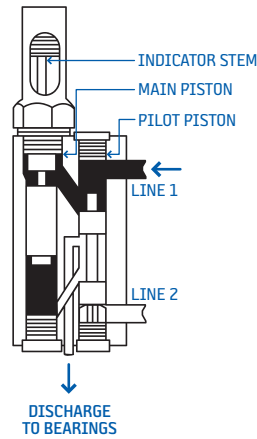

#### DM Valve

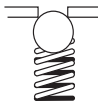
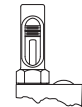
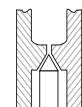
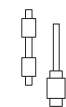
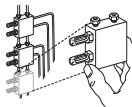

### Features

<p>No springs or check valves.</p> 	<p>Positive indication at every bearing.</p> 
<p>No small ports.</p> 	<p>Has only two moving parts.</p> 
<p>No system redesign when adding or subtracting points.</p> 	<p>Individual adjustability.</p> 

## DD & DM Valve Output

Model	Discharge per piston stroke		Discharge change per adj. screw revolution	Total adj. range
	Minimum	Maximum		
DD-2X	.09cc (.006 cu. in.)	.59cc (.036 cu. in.)	.03cc (.002 cu. in.)	0.45" (11mm)
DD-5X	.18cc (.011 cu. in.)	4.74cc (.289 cu. in.)	.18cc (.011 cu. in.)	1.21" (30mm)
DM-3X	.19cc (.012 cu. in.)	1.18cc (.072 cu. in.)	.08cc (.005 cu. in.)	0.56" (14mm)
DM-4X	.59cc (.036 cu. in.)	2.21cc (.135 cu. in.)	.11cc (.007 cu. in.)	0.69" (17mm)
DM-5X	1.23cc (.075 cu. in.)	5.01cc (.306 cu. in.)	.16cc (.010 cu. in.)	1.12" (28mm)
DM-6X	2.95cc (.180 cu. in.)	13.11cc (.800 cu. in.)	.64cc (.039 cu. in.)	0.97" (24mm)

Note: All DD & DM valves are rated to 3500 psi (240 bar) max.

## Typical Valve Layout

### DD Valve

A typical four valve DD block with eight discharge ports. The valves can easily be converted from dual to single discharge by a cross porting kit. Valve can be reconverted later to dual discharge.

- + Brass indicator housing standard
- + Solid copper crush washers for superior sealing
- + Viton seals standard 350°F (163°C)
- + Easy ID if using single or dual outlet plugs
- + Stainless steel indicator pins standard
- + NPT or BSP outlets available will accept all standard fittings and Farval U81 fittings
- + 10,000 psi rated Koenig plugs used to seal machining ports
- + Solid pin connection to main piston
- + Available in 1-12 lubrication outlets

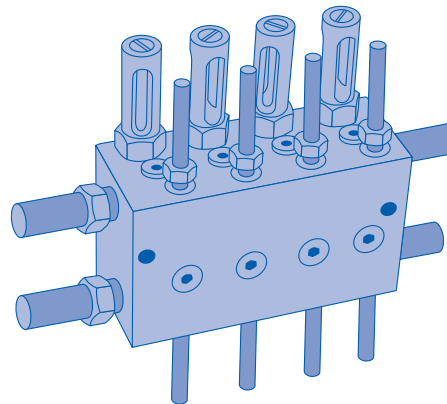

### DM Valve

A typical one valve DM block. Valve has a discharge port on the bottom. A four valve block would have four discharge ports.

- + Supply ports from pump
- + Adjustment screw (varies valve output)
- + Indicator stem (shows that valve is operating)
- + Check valve (required in discharge port of some oil systems)

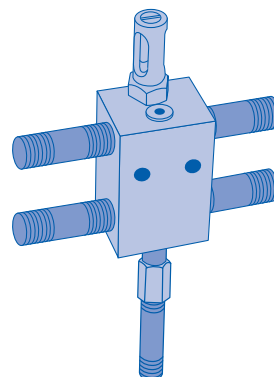

## U-81 One Piece Nut & Sleeve

Tube to male pipe. Farval U-81 connectors allow you to connect both supply and discharge lubrication lines to the DD or DM valves. It is rated beyond the burst pressure of the tubing used.

### U-81 Assembly Procedure

1. Cut tubing off squarely and remove burrs from cut end. (Do not chamfer outside of tubing.)

2. Insert tubing into fitting.

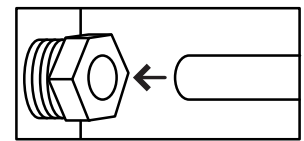

3. Make sure tubing bottoms against valve shoulder.

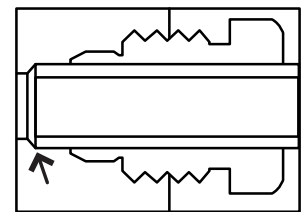

4. Hold tubing against shoulder and tighten nut.

5. When sleeve shears, give nut additional 1 to 2 turns.

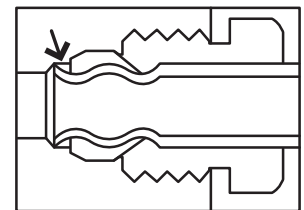

## How to Order

Name	Lube points (#)	Basic valve without connectors	Basic valve with U-81-XX connectors	Basic valve without indicator stem	Basic valve without indicator stem and with connectors
DD Valve	2	DD22250	DD22250T <sup>1</sup>	DD22251	DD22251T <sup>1</sup>
	4	DD24250	DD24250T <sup>1</sup>	DD24251	DD24251T <sup>1</sup>
	6	DD26250	DD26250T <sup>1</sup>	DD26251	DD26251T <sup>1</sup>
	8	DD28250	DD28250T <sup>1</sup>	DD28251	DD28251T <sup>1</sup>
	2	DD52250	DD52250T <sup>2</sup>	DD52251	DD52251T <sup>2</sup>
	4	DD54250	DD54250T <sup>2</sup>	DD54251	DD54251T <sup>2</sup>
	6	DD56250	DD56250T <sup>2</sup>	DD56251	DD56251T <sup>2</sup>
	8	DD58250	DD58250T <sup>2</sup>	DD58251	DD58251T <sup>2</sup>
	10	DD510250	DD510250T <sup>2</sup>	---	---
	12	DD512250	DD512250T <sup>2</sup>	---	---
	12	DD512C250 (BSPP)	---	---	---
DM Valve	1	DM31100	DM31100T <sup>2</sup>	---	---
	2	DM32100	DM32100T <sup>2</sup>	---	---
	3	DM33100	DM33100T <sup>2</sup>	---	---
	4	DM34100	DM34100T <sup>2</sup>	---	---
	1	DM41100	DM41100T <sup>2</sup>	---	---
	2	DM42100	DM42100T <sup>2</sup>	---	---
	3	DM43100	DM43100T <sup>2</sup>	---	---
	4	DM44100	DM44100T <sup>2</sup>	---	---
	1	DM51100	DM51100T <sup>2</sup>	---	---
	2	DM52100	DM52100T <sup>2</sup>	---	---
	3	DM53100	DM53100T <sup>2</sup>	---	---
	4	DM54100	DM54100T <sup>2</sup>	---	---
	1	DM61100A	DM61100AT <sup>2</sup>	---	---
	2	DM62100A	DM62100AT <sup>2</sup>	---	---
	1	DM62101A <sup>3</sup>	DM62101AT <sup>2</sup>	---	---

<sup>1</sup> Supply 1/4" tube; discharge 3/16" tube <sup>2</sup> Supply 3/8" tube; discharge 1/4" tube <sup>3</sup> Discharge supply twice DM61

When ordering specify by name, lube points and part number, e.g. DM Valve without connectors, 3 lube points, Part #DM33-100.

### U-81 One Piece Nut & Sleeve

Tube Size A	Pipe Size B	Steel Part #	Brass Part #
3/16" NPT	1/8" NPT	U-81-AA1	U-81-AA1B
1/4" NPT	1/8" NPT	U-81-B1	U-81-B1B
1/4" NPT	1/4" NPT	U-81-B2	U-81-B2B
3/8" NPT	3/8" NPT	U-81-D3	U-81-D3B

Note: Steel tube fittings are to be used with seamless steel or copper metal plated steel tubing. Brass tube fittings are to be used with brass, copper or nylon tubing only.

### Micro Switch Kits

Description	Part #
For DM30 series	KIT13025B
For DM40 series	39877
For DM60 series	KIT13009B
For DD50 series & DM50 series	KIT13014B
For DM60 series with NEMA 4 switch	KIT13009B4
For DD50 & DM50 with NEMA 4 switch	39145

*Note: Need one kit for each indicator pin.*

### Porting Kits (Optional)

Description	Part #
For field conversion to single outlet. For DD20 series	DDK20-200
For DD50 series	DDK30-200

## Dimensional Schematics

### U-81 One Piece Nut & Sleeve

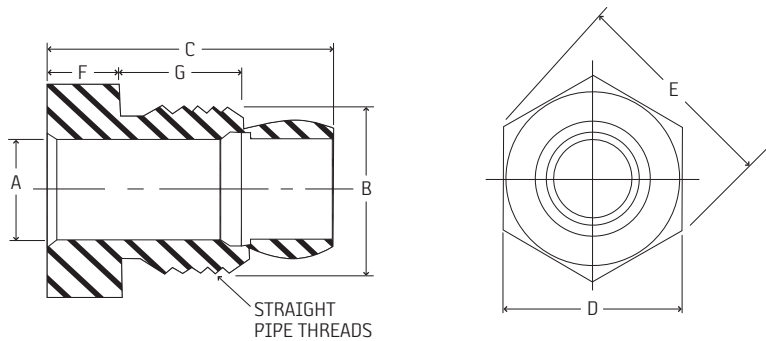

Dimensions				
C	D (HEX)	E	F	G
0.84"	0.44"	0.51"	0.23"	0.33"
0.75"	0.44"	0.51"	0.22"	0.34"
0.94"	0.56"	0.65"	0.25"	0.50"
1"	0.69"	0.79"	0.25"	0.44"

### DD20 Valve

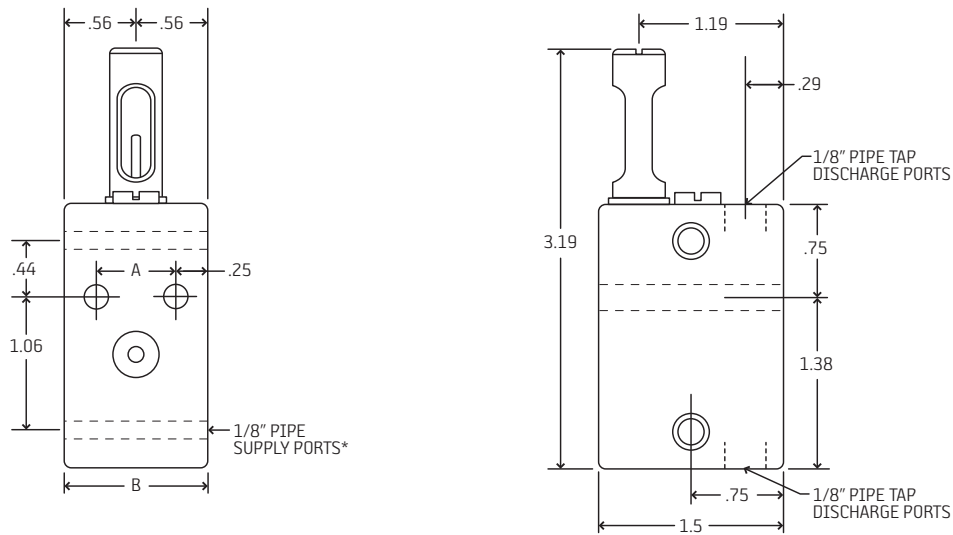

**ATTENTION**

\* All DD models have 4 pipe supply ports.

Discharge Ports	A	B
2	0.63"	1.13"
4	1.19"	1.69"
6	1.75"	2.25"
8	2.31"	2.81"

### DD50 Valve

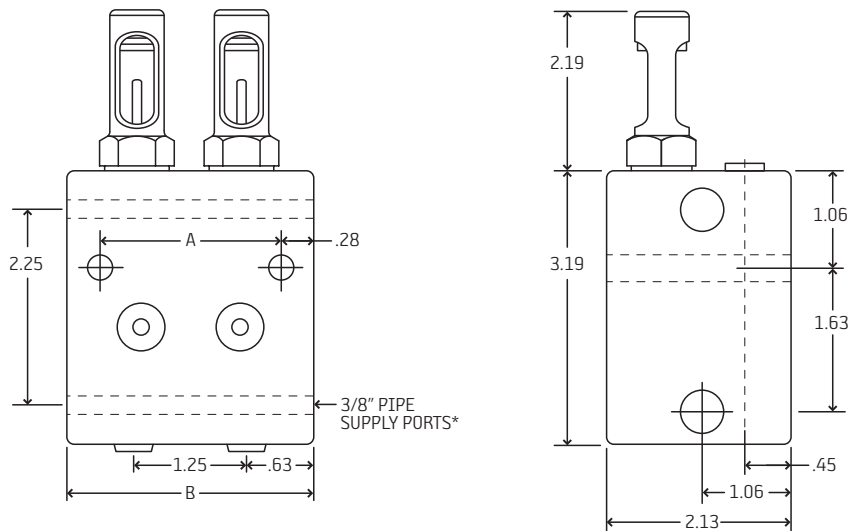

Discharge Ports	A	B
2	1.19"	1.75"
4	2.44"	3"
6	3.69"	4.25"
8	4.94"	5.5"

### DM Valve

**ATTENTION**

\* All DM models have 4 pipe supply ports.

Discharge ports on bottom only:  
 1/8" pipe for DM 31, 32, 33, 34  
 1/4" pipe for all other DM valves

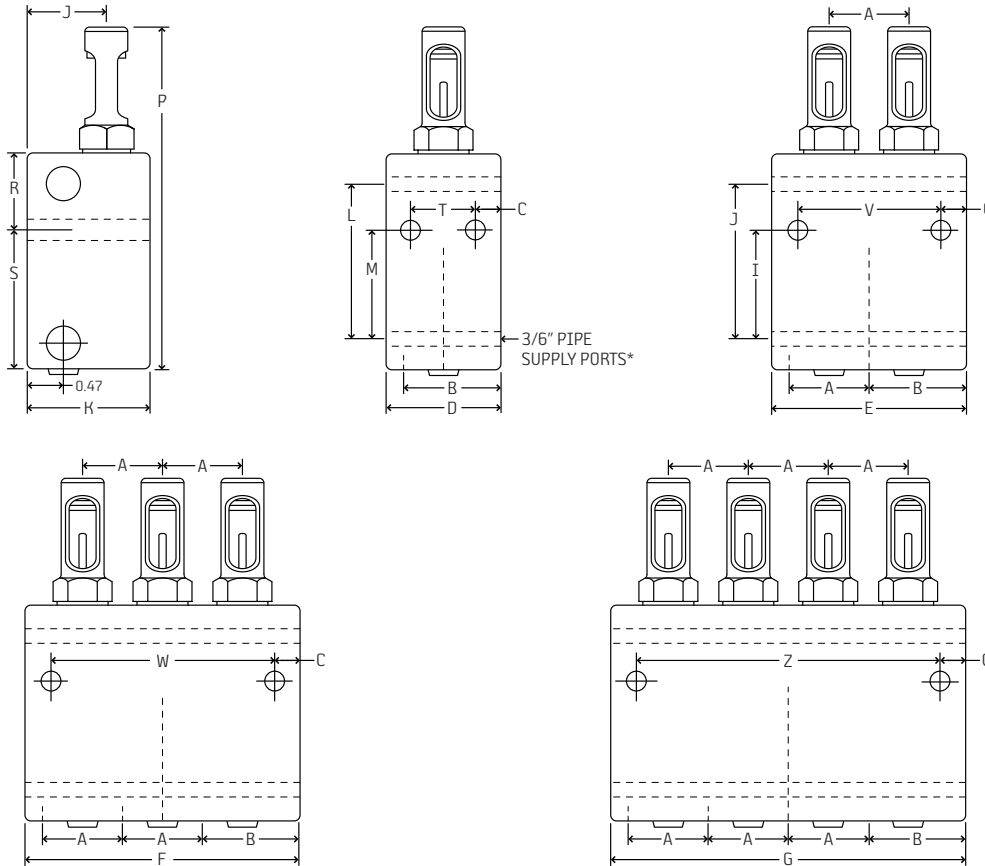

	DM31	DM32, 33, 34	DM41, 42, 43, 44	DM51, 52, 53, 54	DM61, 62
A	1.13"	1.13"	1.25"	1.44"	1.81"
B	1.44"	1.44"	1.56"	1.69"	2.03"
C	0.47"	1.44"	0.41"	0.41"	0.41"
D	1.75"	---	1.94"	2.13"	2.44"
E	---	2.88"	3.19"	3.56"	4.25"
F	---	4"	4.44"	5"	---
G	---	5.13"	5.69"	6.44"	---
J	1.09"	1.09"	1.16"	1.28"	1.47"
K	1.5"	1.5"	1.56"	1.75"	2.25"
L	1.63"	1.63"	2.19"	2.19"	2.19"
M	1.09"	1.19"	1.5"	1.56"	1.56"
P	3.94"	3.94"	4.75"	5.44"	5.94"
R	0.97"	0.88"	1.09"	1.16"	1.28"
S	1.53"	1.63"	1.91"	2.09"	2.22"
T	0.81"	---	1.06"	1.31"	1.63"
V	---	---	2.31"	2.75"	3.44"